

SPORTSOUND® 2000HD
AUDIO SYSTEM
INSTALLATION MANUAL

P1340

DD1798478
Rev 12
30 July 2021

FCC Statement

Supplier Declaration of Conformity (SDoC)

This product complies with Part 15 of the FCC Rules. Operation is subject to the following two conditions: (1) This device may not cause harmful interference, and (2) this device must accept any interference received, including interference that may cause undesired operation.

Note: This equipment has been tested and found to comply with the limits for a Class A digital device, pursuant to part 15 of the FCC Rules. These limits are designed to provide reasonable protection against harmful interference when the equipment is operated in a commercial environment. This equipment generates, uses, and can radiate radio frequency energy and, if not installed and used in accordance with the instruction manual, may cause harmful interference to radio communications. Operation of this equipment in a residential area is likely to cause harmful interference in which case the user will be required to correct the interference at their own expense.

Warning: The user is cautioned that changes and modifications made to the equipment without the approval of manufacturer could void the user's authority to operate this equipment.

Industry Canada Regulatory Information

This Class A digital apparatus complies with Canadian ICES-003.

Cet appareil numérique de la classe A est conforme à la norme NMB-003 du Canada.

Inquiries

Contact Daktronics with any questions regarding our product compliance.

Mail:

Daktronics
201 Daktronics Dr.
Brookings, SD 57006 USA

Phone:

800-325-8766

Website:

www.daktronics.com



DAKTRONICS

Copyright © 2010-2021

All rights reserved. While every precaution has been taken in the preparation of this manual, the publisher assumes no responsibility for errors or omissions. No part of this book covered by the copyrights hereon may be reproduced or copied in any form or by any means—graphic, electronic, or mechanical, including photocopying, taping, or information storage and retrieval systems—without written permission of the publisher.

Daktronics trademarks are property of Daktronics, Inc. All other trademarks are property of their respective companies.

Table of Contents

1	Introduction	1
	Important Safeguards.....	1
	Resources	1
	Daktronics Nomenclature	2
2	Sound System Components	3
	Equipment Overview	3
	Sound Cabinet.....	3
	Grille	3
	Drivers	3
	Amplifier Components	4
	Fiber Conversion Box.....	4
	Audio Control Rack.....	4
	Signal Cables	4
3	Mechanical Installation	5
	Cabinet Installation	5
	Lift the Cabinet	5
	Mount the Cabinet	6
	Aim the Speakers	7
4	Electrical Installation	8
	Power/Signal Connections.....	8
	Power IN	9
	Signal IN	10
	Grounding	10
	Lightning Protection	10
	Fiber Conversion Box Connections.....	10
5	Maintenance	12
	Grille Maintenance and Cleaning	12
	Grille Mesh Replacement	12
6	Troubleshooting	15
	Indicator Lights.....	17
	Audio Control Rack	17
	Fiber Conversion Box	17
	System Testing	17
	Driver Troubleshooting	17
	Driver Replacement	19
	High-Frequency Driver (A-2302)	19
	Mid-Frequency Driver (A-2305)	20
	Low-Frequency Driver (A-2306)	21
	Amplifier Troubleshooting and Replacement	22
	Media Converters.....	23
	Typical Component Settings	23
	Verifying Network Activity	23

Table of Contents

Input/Output Expander	24
Typical Component Settings	24
Verifying Network Activity	24
Checking for Input Signal	24
Checking for Output Signal	25
Replacement Parts.....	25
Sound Cabinet	25
Fiber Conversion Box	25
7 Daktronics Exchange and Repair & Return Programs	26
Exchange Program	26
Repair & Return Program.....	27
Daktronics Warranty & Limitation of Liability	27
A Reference Drawings	29
B Supplementary Manuals	43
C Daktronics Warranty & Limitation of Liability	45

1 Introduction

This manual explains the installation, maintenance, and troubleshooting of a Sportsound® 2000HD Audio System. For additional information regarding safety, installation, operation, or service, refer to the telephone numbers listed in **Section 7: Daktronics Exchange and Repair & Return Programs (p.26)**. This manual is not specific to a particular installation.

Important Safeguards

- **Read and understand all instructions before beginning the installation process.**
- **Disconnect system power when not in use or when servicing.**
- **Disconnect system power before servicing power supplies to avoid electrical shock. Power supplies run on high voltage and may cause physical injury if touched while powered. Several disconnect switches may be required to de-energize the equipment.**
- **Do not modify the cabinet structure or attach any panels or coverings without the express written consent of Daktronics.**
- **Do not disassemble control equipment or electronic controls of the system; failure to follow this safeguard will make the warranty null and void.**
- **Do not drop the control equipment or allow it to get wet.**
- **Always turn off and/or unplug the control equipment when it is not in use. This keeps equipment protected from power spikes and lightning.**
- **Inspect equipment for shipping damage such as rattles and dents, and verify that all equipment is included as itemized on the packing slip. Immediately report any problems to Daktronics; save all packing materials if exchange is necessary.**

Resources

Figure 1 illustrates a Daktronics drawing label. The drawing number is located in the lower-right corner of a drawing. This manual refers to drawings by listing the last set of digits. In the example, the drawing would be referred to as **DWG-1007804**. All references to drawing numbers, appendices, figures, or other manuals are presented in bold typeface. Any drawings referenced in a particular section are listed at the beginning of it as shown below:

		DAKTRONICS, INC. BROOKINGS, SD 57006 DO NOT SCALE DRAWING	THE CONCEPTS EXPRESSED AND DETAILS SHOWN ON THIS DRAWING ARE CONFIDENTIAL AND PROPRIETARY. DO NOT REPRODUCE BY ANY MEANS WITHOUT THE EXPRESSED WRITTEN CONSENT OF DAKTRONICS, INC. COPYRIGHT 2010 DAKTRONICS, INC.
PROJ: DAKTRONICS			
TITLE: SYSTEM RISER DIAGRAM			
DESIGN:	DRAWN: APAGE		DATE: 11 MAY 10
SCALE: NONE			
SHEET	REV	JOB NO:	FUNC-TYPE-SIZE
200	02	C17581	F-01-D
			1007804

Drawing Number

Figure 1: Drawing Label

Reference Drawing:

System Riser Diagram **DWG-1007804**

Daktronics identifies manuals by the DD or ED number located on the cover page.

Daktronics has a searchable knowledgebase of common questions and troubleshooting tips: www.daktronics.com/support.

Visit the Daktronics Support YouTube channel to learn how to properly operate Sportsound systems: www.youtube.com/DaktronicsSupport.



Project-specific information takes precedence over any other general information found in this manual. Such information may include:

- **Schematic Drawings:** describe internal power and signal wiring
- **Shop Drawings:** describe mounting methods to structural elements, access method (front or rear), and power and signal entrance points
- **System Riser Diagrams:** describe power and signal connections between system components and the control location; may also include control room layout and schematic
- **Final Assembly Drawings:** describe internal component locations and detailed product appearance with part numbers and quantities

Ensure all applicable material has been gathered before beginning the installation. Contact a Daktronics sales coordinator or project manager.

Daktronics Nomenclature

Most components have a white label that lists the part number (**Figure 2**). Part numbers will also appear on certain drawings. If a component is not found in the **Replacement Parts (p.25)**, use the label to order a replacement. Refer to **Section 7: Daktronics Exchange and Repair & Return Programs (p.26)** if replacing or repairing any component.

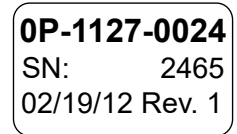

Figure 2: Part Label

Main Component Labels	
Part Type	Part Number
Individual circuit board	0P-XXXX-XXXX
Assembly; a collection of circuit boards	0A-XXXX-XXXX
Wire or cable	W-XXXX
Fuse	F-XXXX
Transformer	T-XXXX
Metal part	0M-XXXXXXX
Fabricated metal assembly	0S-XXXXXXX
Specially ordered part	PR-XXXXX-X

Accessory Labels	
Component	Label
Termination block for power or signal cable	TBXX
Grounding point	EXX
Power or signal jack	JXX
Power or signal plug for the opposite jack	PXX

2 Sound System Components

Equipment Overview

The Sportsound 2000HD audio system consists of the following elements:

- Sound Cabinet
- Fiber Conversion Box
- Audio Control Rack
- Signal Cables

Note: All products in this system are tested individually for product safety approval.

Sound Cabinet

The Sportsound 2000HD sound system cabinet (**Figure 3**) is 6'-0" (1829 mm) high, 22'-0" (6.71 m) wide, and 3'-6" (1067 mm) deep. It is composed of a steel skeleton sheeted in custom aluminum paneling with eight rear access doors. The cabinet is powder coat black with a wrinkle finish.

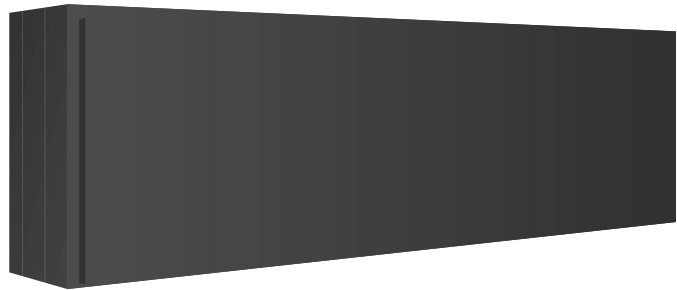

Figure 3: 2000HD Sound Cabinet with Grille

Grille

Reference Drawing:

Mesh Layout; 2000HD Gen II **DWG-983337**

The grille of the cabinet consists of a woven flame resistant acoustical mesh. The mesh can be printed in a variety of colors to display advertising, sponsors, or logo designs. The printable area is 5'-4.75" (1645 mm) high by 21'-9" (6.63 m) wide.

Drivers

Three different types of drivers (also known as speakers) are used in the sound cabinet (**Figure 4**):

- 12" (381 mm) low frequency drivers: Daktronics part # A-2306
- 8" (203 mm) mid-range drivers: Daktronics part # A-2305
- 1.4" (36 mm) high frequency drivers: Daktronics part # A-2302

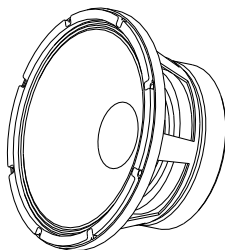

A-2306

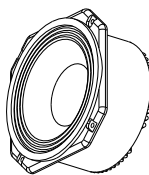

A-2305



A-2302

Figure 4: 2000HD Drivers

Amplifier Components

In sound systems, the amplifier is the last component before the drivers. It receives a signal from the source equipment and amplifies it to power the drivers. The Sportsound 2000HD sound system utilizes ten (10) power amplifiers with built-in Digital Signal Processor (DSP), which manages equalization, limiting, compression, and crossover functions.

The DSP program is set at the factory and is not user-adjustable.

Fiber Conversion Box

The fiber conversion box (**Figure 5**) converts the analog audio signal from the audio control rack into fiber optic signal that goes out to the sound cabinet. The box is typically permanently wall-mounted near the source equipment location.

The fiber conversion box includes an analog backup signal. This provides a redundant safety, in case the fiber link to the sound cabinet is lost. To go into analog backup mode, simply turn the switch to the **ANALOG** position.

Refer to **Fiber Conversion Box Connections (p.10)** for more information about the fiber conversion box.



Figure 5: Fiber Conversion Box

Audio Control Rack

The Sportsound 2000HD audio system is compatible with all Daktronics standard control racks. Refer to the manual provided with the control rack for proper operation.

Signal Cables

Cable specifications are as follows:

- Minimum 2-core, multimode 50-micron fiber optic cable from fiber conversion box to the sound cabinet. If included with a Daktronics scoreboard or display, the sound system may share a fiber optic cable run, requiring additional cores.
- 1 pair, 22 AWG audio cable from fiber conversion box to sound cabinet for analog backup (part # W-1615)
- 50' (15.2 m) fiber patch cable from fiber splice box to sound cabinet (part # W-1512)

3 Mechanical Installation

A qualified technician must install the Sportsound 2000HD sound system cabinet. It is the customer's responsibility to ensure that a qualified structural engineer approves the mounting structure and any additional hardware needed to secure the cabinet.

The cabinet must be installed no farther than 100' (31 m) behind the goal post to provide coverage for seating from goal to goal.

Note: Daktronics assumes no responsibility for the structure's integrity. The engineer responsible for the attached-to base structure shall evaluate the adequacy of their structure to support the gravity loads imparted by the cabinet at each attachment point in combination with other associated loading conditions. Daktronics assumes no responsibility for system damage or injury resulting from installation methods that deviate from attachment details specified on shop drawings. Daktronics also assumes no liability for system damage or injury resulting from incorrect setup or lifting methods performed by non-Daktronics employees.

Cabinet Installation

Reference Drawings:

Shop Drawing; Sound System; 2000HD **DWG-330901**

Mechanical installation consists of lifting and mounting the Sportsound 2000HD cabinet onto an existing support structure. Refer to **DWG-330901** in **Appendix A**.

Lift the Cabinet

The Sportsound 2000HD cabinet is shipped with four (4) 5/8" lift eyes for lifting it into place (**Figure 6**).

Note: The two smaller front lift eyes are meant only for removing the grille frame and not for lifting the cabinet. Refer to **Grille Mesh Replacement (p.12)**.

Three (3) shipping brackets are installed to the top of the cabinet for shipping purposes only. Each bracket is attached to the cabinet with two (2) 1/2" hardware sets. Remove all shipping brackets prior to lifting and installing the cabinet.

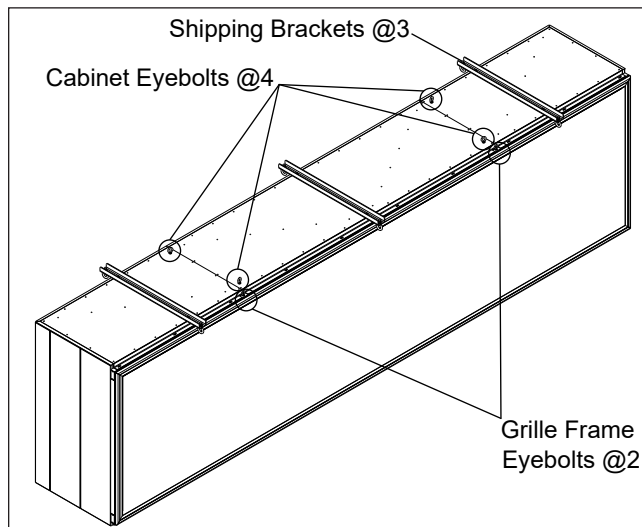

Figure 6: Eyebolts & Shipping Brackets

Whenever possible, use a spreader bar, or lifting bar, to lift the cabinet. Spreader bars ensure force on the eyebolts remains straight up, minimizing lifting stress.

Figure 7 illustrates the preferred lifting method on the left and an acceptable alternative lifting method on the right. When lifting the cabinet:

- Use a spreader bar if possible.
- Use every lifting point provided.

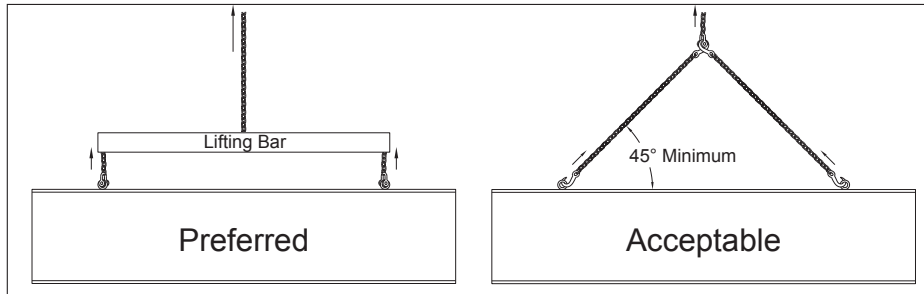

Figure 7: Lifting Methods

Cables and chains attached to the eyebolts and directly to a center lifting point, as shown in the "Acceptable" example in **Figure 7**, can create a dangerous lateral force on the eyebolts and may cause the eyebolts to fail. The smaller the angle between the cable and the top of the cabinet, the lighter the cabinet must be to safely lift it. If this method must be used, ensure a minimum angle between the chain and cabinet of at least 45°.

Do NOT attempt to lift the cabinet if the angle is less than 45°. Exceeding load angles or weight limits could cause the bolts in the cabinet to buckle, resulting in serious damage to the equipment or injury to personnel. Also, loads should be applied directly in the plane of the eyebolt as shown in **Figure 8**.

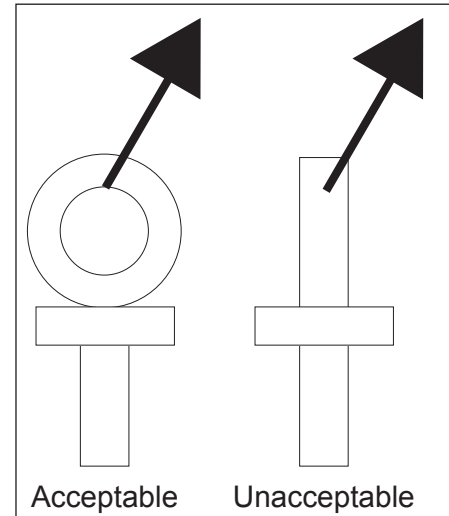

Figure 8: Eyebolt Plane Load

Note: Daktronics assumes no liability for damages resulting from incorrect setup or lifting methods. Eyebolts are intended for lifting only. Do not attempt to permanently support the cabinet by the eyebolts or eyebolt holes.

If installers remove the eyebolts, use 5/8" bolts to plug the holes.

Mount the Cabinet

Reference Drawings:

Shop Drawing; Sound System; 2000HD **DWG-330901**

The sound cabinet will be mounted atop a frame that must be certified by a structural engineer. To mount the system in place, position the cabinet on the structure where it is to be mounted. Weld the cabinet's bottom members to the structure at the locations indicated on the shop drawing. Refer to **DWG-330901** in **Appendix A** for mounting requirements.

Aim the Speakers

Reference Drawings:

Speaker Adjustment Chart; 2000HD **DWG-1023805**

Once the cabinet has been mounted in place, it may be necessary to adjust the direction of the speakers for the individual facility. **DWG-1023805** in **Appendix A** provides speaker aiming instructions as well as recommended angles to position the speakers, based on the cabinet's location in relation to the seating area(s).

4 Electrical Installation

CAUTION – RISK OF ELECTRIC SHOCK: Only qualified individuals should perform power routing and termination to the system. It is the responsibility of the electrical contractors to ensure that all electrical work meets or exceeds local and national codes. Failure to follow installation guidelines will result in audible noise on the sound system and possible damage to internal components.

Note: This product is not provided with mains disconnect. Customer shall provide disconnect at base of sound system location that meets or exceeds local and national electrical codes. Several disconnect switches may be required to de-energize the equipment before servicing.

Note: The control enclosure, located in the sound cabinet, shall not be exposed to dripping or splashing, and no objects filled with liquid shall be placed on the control enclosure.

Power/Signal Connections

Reference Drawings:

System Riser; 2000HD	DWG-984140
System Riser; Electrical & Audio Notes	DWG-985713
Schematic; Control Enclosure/Sound Cabinet 2000HD.....	DWG-1082599

DWG-984140 details power and signal connections of the Sportsound 2000HD sound system. To gain access to internal power and signal connection points, open the far right rear access door (**Figure 9**). Turn all latches a 1/4 turn using a flathead screwdriver (older latches can be turned with fingers). Tilt the top of the door away from the cabinet. With the door tilted, use the handle to lift it up and out of the doorframe.

Note: To remove the front grille frame, refer to **Grille Mesh Replacement (p.12)**.

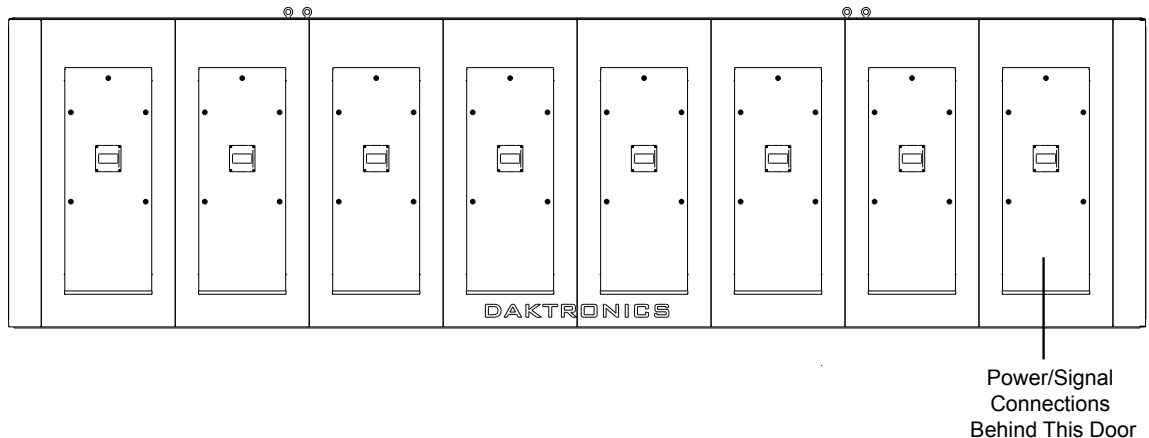

Figure 9: Sound Cabinet Access Doors, Rear View

To access the internal components of the control enclosure, turn both cover latches a 1/4 turn using a flathead screwdriver, and then pull the cover away from the enclosure.

Refer to **Figure 10** for component and connection locations within the sound cabinet and control enclosure and **DWG-1082599** in **Appendix A** for a detailed wiring schematic.

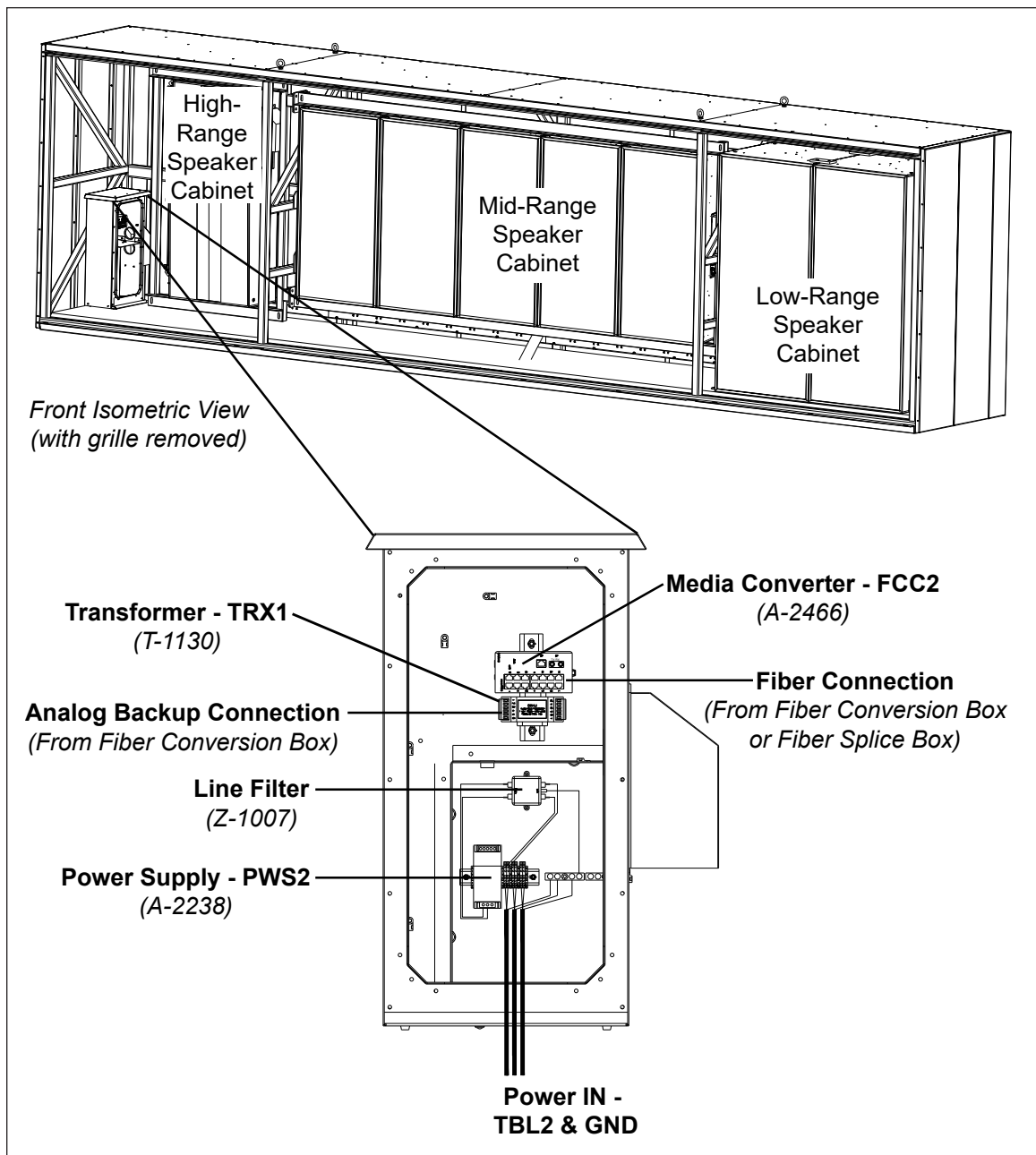

Figure 10: Sound Cabinet & Control Enclosure Components (Covers Removed)

Power IN

The system requires three (3) 20 amp 208/230/240 circuits (50 or 60Hz); 2W + GND. Power wiring must be run in conduit up into the bottom of the sound cabinet and terminated at TBL2. Refer to Detail "F" of **DWG-984140**.

A voltage surge protector (part # A-1129) is provided for additional protection at the main breaker panel. Refer to **Figure 11** and Detail "G" of **DWG-984140**.



Figure 11: Surge Protector

Signal IN

A minimum of 2-core, multimode 50-micron fiber optic cable must be run in conduit from the fiber conversion box location and terminated in a fiber splice box near the sound cabinet. Fiber patch cables (part # W-1512) will then run in conduit to the control enclosure media converter (FCC2). Refer to Detail "C" and Detail "E" of **DWG-984140**. If there is no fiber splice box, the fiber is terminated directly to the media converter. If included with a Daktronics scoreboard or display, the sound system may share a fiber optic cable run, requiring additional cores.

For the analog backup signal, 1 pair, 22 AWG cable (part # W-1615) must also be run in conduit from the fiber conversion box location to the sound cabinet control enclosure (TRX1). Refer to Detail "E" of **DWG-984140**. The analog backup cable may pass through, but not terminate in, a fiber splice box.

Grounding

All components of an audio system – including but not limited to control equipment, and connected peripheral equipment – must be electrically grounded. Only qualified individuals may perform electrical work, including verification of ground resistance. Daktronics is not responsible for improper grounding or damage incurred as a result of improper grounding.

Grounding methods must meet the provisions of all applicable local and national codes. Inspect and verify all grounding methods meet the provisions of all applicable local and national codes.

Proper grounding is necessary for reliable equipment operation and general electrical safety. Failure to properly ground the sound system may void the warranty, disrupt operation, damage equipment, and cause bodily harm or death.

Lightning Protection

The use of a disconnect near the system to completely cut all current-carrying lines significantly protects the circuits against lightning damage. In order for this device to provide protection, the power must be disconnected when the system is not in use.

Fiber Conversion Box Connections

Reference Drawings:

System Riser; 2000HD	DWG-984140
Audio; Sportsound, Fiber Box Schematic.....	DWG-1095894

IMPORTANT NOTES:

- The fiber box shall not be exposed to dripping or splashing, and no objects filled with liquid shall be placed on the fiber box.
- The fiber box consists of Class 1 construction and shall be connected to a mains socket outlet with a protective earth-ground connection.
- The fiber box utilizes a power cord with wiring inlet as a means for disconnection from power. This means of disconnection shall remain readily operable in all cases.

Refer to **Figure 12** for external fiber conversion box connections and **Figure 13** for internal connections and component locations.

Refer to Detail "A" in **DWG-984140** for analog backup connection and Detail "B" for fiber connection. **DWG-1095894** provides a detailed wiring schematic.

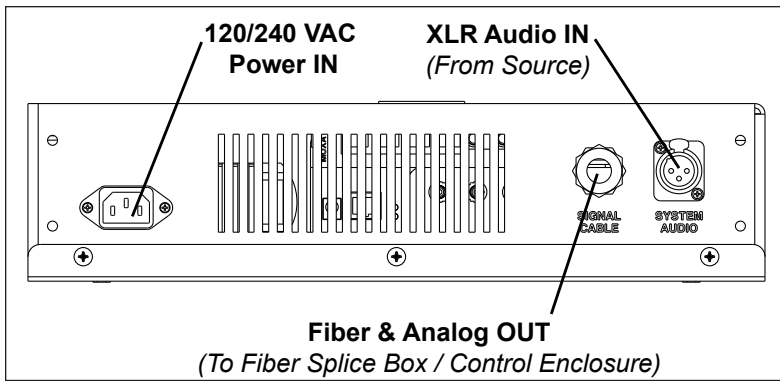

Figure 12: External Fiber Conversion Box Connections

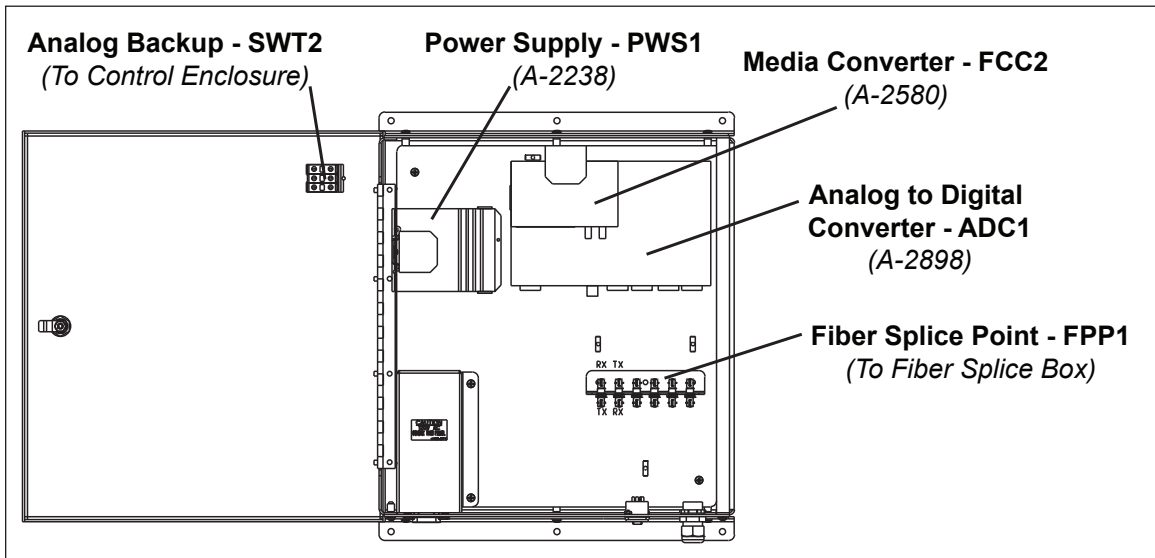

Figure 13: Internal Fiber Conversion Box Connections & Components (Cover Open)

5 Maintenance

Grille Maintenance and Cleaning

To allow maximum acoustic transparency, the front of the cabinet contains a PVC mesh grille. Do not apply anything to the surface that may obstruct the holes in the material. To maintain the brightness of the colors and prolong the life of the grille, periodic cleaning is necessary. Failure to clean periodically may result in permanent discoloration or staining. When cleaning, use a mild soapy solution (Dove®, Ivory®, etc.) and a very soft brush, moving in a circular motion. Rinse with clean water using normal faucet pressure.

Do not use a power washer.

Grille Mesh Replacement

Reference Drawings:

Mesh Layout; 2000HD Gen II **DWG-983337**

If the grille mesh fades or tears over time, or if new graphics/logos are desired, it may be replaced. Only qualified sign companies should be used to replace the grille mesh. Refer to **DWG-983337** for mesh layout. Contact Daktronics for mesh reordering.

1. Remove Mesh Frame

The front of the sound cabinet has a removable aluminum frame that secures the grille mesh (**Figure 14**).

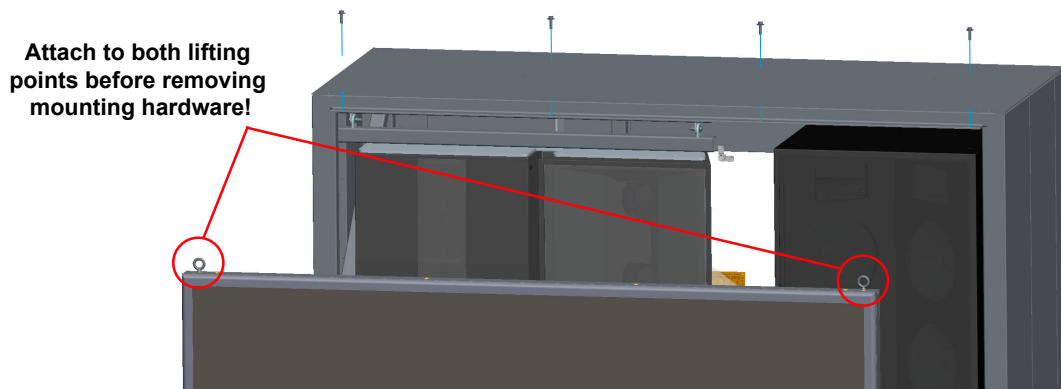

Figure 14: Grille Frame Removal (1500HD cabinet shown)

- a. Attach cables or chains to both eyebolts on the grille frame. Follow the lifting guidelines in **Cabinet Installation (p.5)**.
- b. Remove all mounting hardware. The frame is attached to the sound cabinet with a total of twenty (20) 3/8" hardware sets, with ten (10) sets at both the top and bottom of the frame.
- c. Safely lower the frame to the ground. Set the frame on a level surface large enough so that the weight is supported by the aluminum frame and not on the mesh.
- d. Loosen the screws on the radius cover using a square driver and remove.

2. Remove Tension Clips

Insert the tip of a standard flathead screwdriver into the recess located at the backside of the tension clip (**Figure 15**). Rotate or tilt the screwdriver to separate the tension clip teeth away from the frame. This will allow the tension clip to be removed from the frame by prying or pulling it up and out.

Slide the mandrel out of the tension clip to release the mesh.

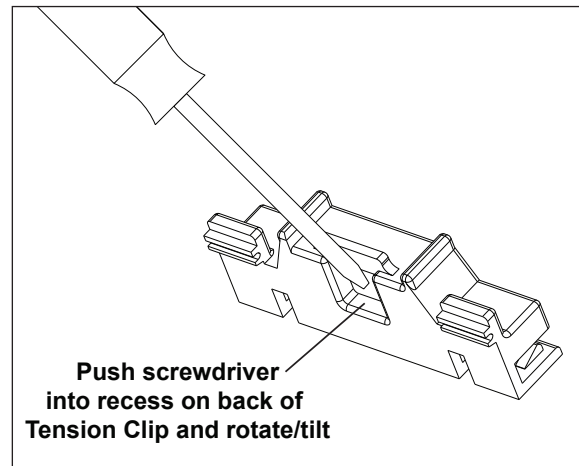

Figure 15: Removing Tension Clips

3. Attach New Mesh

When ordered through Daktronics, the mesh has a line with a series of tick marks printed on the front (**Figure 16**). These tick marks indicate the location of the tension clips and mandrels.

- Place a mandrel, smooth side up, centered on the tick mark.
- Fold the mesh around the mandrel. Ensure the groove in the mandrel is towards the inside of the mesh (**Figure 17**).



Figure 16: Tick Marks on Mesh

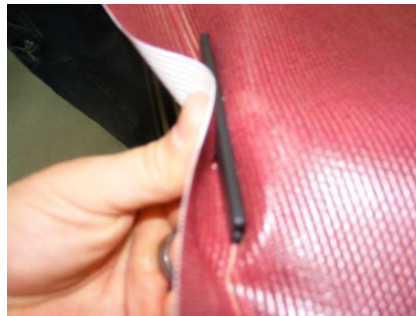

Figure 17: Folding Mesh

- Snap a tension clip over the mandrel and mesh (**Figure 18**). Do not try to drive both ends of the clip down onto the mandrel and fabric at the same time; snap one end down and then the other.

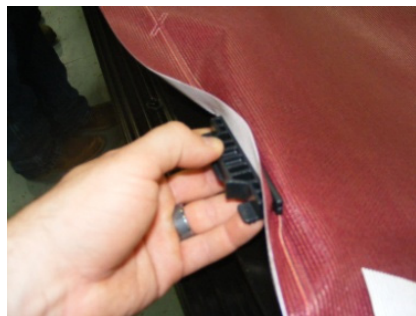

Figure 18: Attach Tension Clip

- d. Continue to place a mandrel and tension clip on every tick mark.
- e. Lay the mesh across the frame and snap each clip into the tension channels (**Figure 19**).
- f. Pull on the corners of the mesh to remove any wrinkles. When pulling on the fabric, do not pull directly on the fabric flap or tension clip, or the clip may pop off. When pulling on the face, grasp the fold and pull the face into place.
- g. Use the tensioning tool provided with the mesh replacement kit (part # 0A-1340-2032) to drive the tension clips into the tension channels (**Figure 20**). Start with one or two clicks.

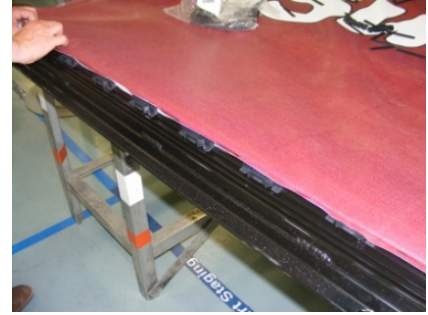

Figure 19: Clips in Channels

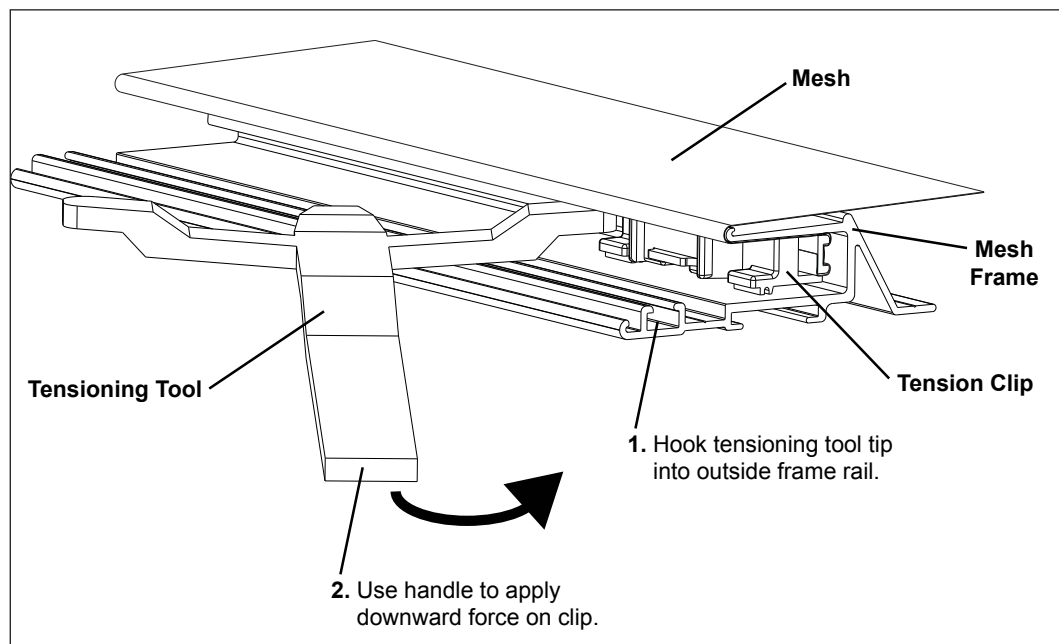

Figure 20: How to Use Tensioning Tool

- h. Work around the frame, tightening down all the tension clips until all the wrinkles are removed and the mesh is properly taut. **Do not over-tension!** This may cause damage to mesh graphics. Apply just enough tension to achieve a smooth, flat surface.
- i. Place the radius covers on the end of the mesh frame and tighten the set screws on the radius cover.

4. Reattach Mesh Frame

Safely lift mesh frame back in place on the front of the sound cabinet and attach with the twenty (20) 3/8" hardware sets. Ensure the frame is snug tight against the cabinet.

6 Troubleshooting

This section lists potential problems with the system, indicates possible causes, and suggests corrective action. This list does not include every possible problem, but it does represent some of the more common situations that may occur.

Note: Be sure to power on the audio control rack, fiber conversion box, and cabinet breakers. Make sure all connections from source to the cabinet are intact.

Symptom/Condition	Possible Cause	Solution/Items to Check
No power to audio cabinet; green indicator light is off on bottom of control enclosure	Breaker is off at sign	Turn breaker ON.
	Bad power supply	Order a new power supply (part # A-2238).
No audio from cabinet, but signal can be heard through headphones or a monitor speaker	No power at cabinet	Turn breaker ON.
	Fiber conversion box is unplugged from wall outlet or cable to audio control rack	Plug in fiber conversion box power/signal.
	Analog signal out of the mixer is not being correctly converted to a digital signal	Set the fiber box ANALOG BACKUP switch (Figure 30) to ANALOG and see if problem goes away.
	No fiber connection to cabinet; fiber link down	Verify the Port 1 (100M) LED on the media converter is solid green (Figure 28-2).
		Swap TX-RX fibers to fix link. Replace fiber splice, repair fiber termination/cable.
Isolation transformer failure (ANALOG BACKUP enabled)	Check the isolation transformer in the control enclosure. Refer to the Isolation Transformer Troubleshooting Guide (DD3417357) , located online at www.daktronics.com/manuals .	
Muffled audio from cabinet (but clear through headphones or a monitor speaker)	Bad digital connection	Open CobraNet Discovery and check for errors. Refer to System Testing (p.17) .
	Bad driver or amplifier	Perform a system check via Monitor Application. Refer to System Testing (p.17) .

Symptom/Condition	Possible Cause	Solution/Items to Check
Weak (low level) audio from cabinet	Low level source	Ensure output from the mixer is professional line level.
	Analog signal out of the mixer is not being correctly converted to a digital signal	Set the fiber box ANALOG BACKUP switch (Figure 30) to ANALOG and see if problem goes away.
	Improper gain at Analog to Digital Converter (in fiber box)	Adjust gain according to Biamp Audia Input & Output Expanders Operation Manual in Appendix B .
Poor sound quality from audio cabinet (distortion)	Poor source material (CD or MP3 with heavy compression or distorted material)	Use high quality audio files (.wav).
	Clipping audio at source (audio control rack) output	Bring source level down below clip.
	Bad driver or amplifier	Perform a system check via Monitor Application. Refer to System Testing (p.17) .
Intermittent audio from audio cabinet	Bad fiber connection	Set the fiber box ANALOG BACKUP switch (Figure 30) to ANALOG and see if problem goes away.
	Amplifier modules are over driven into protect mode	Reduce source output level.
	Bad amplifier module	Open CobraNet Discovery and check for errors. Refer to System Testing (p.17) .
	Analog to Digital Converter (in fiber box) failure	Refer to Input/Output Expander (p.24) .
	Low level (-20dB) (ANALOG BACKUP enabled)	Increase source output level above -20dB.
Humming/buzzing from audio cabinet	Ground loop	Disconnect ground at isolation transformer in the control enclosure. Refer to Audio System Humming Troubleshooting (DD3448287) , located online at www.daktronics.com/manuals .

For more troubleshooting steps, refer to the appropriate audio control rack manual.

Indicator Lights

Audio Control Rack

Refer to the troubleshooting section of a specific audio control rack manual for more information about the indicator lights that show signal output to the audio cabinet.

Fiber Conversion Box

Within the fiber conversion box, indicator lights on the equipment help verify proper connection with the sound cabinet. Refer to **Media Converters (p.23)** and **Input/Output Expander (p.24)**.

System Testing

Use the audio system's Monitor Application to verify all channels of amplifiers and drivers are functioning correctly. Refer to the **Sportsound Amplifier Field Guide (DD3318172)**, available online at www.daktronics.com/manuals, for more information.

1. With a full-range audio source (music) playing at a moderate level through the system, click the **Start Monitoring** button.
2. Click the **Standby Protect** button next to each channel to mute them.
3. After muting every channel, un-mute one channel at a time and listen for audio.
4. Un-mute all channels, and stop all source audio from the control rack.
5. Click the **Test Tone** button for **AMP1** and compare the **Impedance** value (in ohms Ω) to the reference ranges shown beneath the Channel #.
6. Repeat Step 5 for all remaining amplifiers. If any impedance values are out of the reference ranges by half or double, test the individual drivers connected to the suspect amplifier(s). Refer to **Driver Troubleshooting (p.17)**.

Driver Troubleshooting

Tools Required: Multi-meter, 9V battery

To access the driver, follow Steps 1-2 in the appropriate driver type section under **Driver Replacement (p.19)**.

Before removing the driver, verify correct DC resistance of the driver using a multi-meter (**Figure 21**). Check the DC resistance of each driver separately, or check the DC resistance at the harness. Connect each lead of the multi-meter to the terminals of the driver (or proper pins on the harness), and make sure the multi-meter is set to measure the DC resistance.

Driver Part Number	Resistance
A-2302 (High Frequency)	8.5 Ω
A-2305 (Mid Frequency)	6.6 Ω
A-2306 (Low Frequency)	6.0 Ω



Figure 21: Mid-Frequency Driver & Meter

Depending on site conditions, the measurements may fluctuate up and down slightly so don't be alarmed; figure out an average. If the resistance is showing near 0 or open, this indicates the coil of the driver is bad and needs to be replaced.

It's possible that the coil is perfectly fine on cone drivers (mids and lows), but the spider, diaphragm, or surround is damaged, eliminating or restricting the cone from moving in and out. Visually check the surround and make sure it is in good condition. It may be necessary to remove the driver from the speaker assembly. Carefully push on the diaphragm and see if it can move in and out to verify the driver is not seized. Apply a 9V battery to the driver terminals and listen for any rubbing or stuck coils.

If the driver checks out fine, further troubleshooting of the system is required.

Note: Daktronics speaker assemblies have drivers wired in parallel. Use the following chart when measuring the DC resistance of a harness. Refer to **Figure 22** for harness connector pinout.

Harness	Channel 1	Channel 2	Channel 3
Amp 1	Pins 2-3 = 2.1 Ω	-	Pins 5-6 = 2.1 Ω
Amp 2	Pins 2-3 = 3.2 Ω	Pins 1-4 = 3.2 Ω	-
Amp 3	Pins 2-3 = 3.2 Ω	Pins 1-4 = 3.2 Ω	-
Amp 4	Pins 2-3 = 3.2 Ω	Pins 1-4 = 3.2 Ω	-
Amp 5	Pins 2-3 = 3.2 Ω	Pins 1-4 = 3.2 Ω	-
Amp 6	Pins 2-3 = 3.2 Ω	Pins 1-4 = 3.2 Ω	-
Amp 7	Pins 2-3 = 3.0 Ω	Pins 1-4 = 3.0 Ω	-
Amp 8	Pins 2-3 = 3.0 Ω	-	-
Amp 9	Pins 2-3 = 3.0 Ω	Pins 1-4 = 3.0 Ω	-
Amp 10	Pins 2-3 = 3.0 Ω	-	-

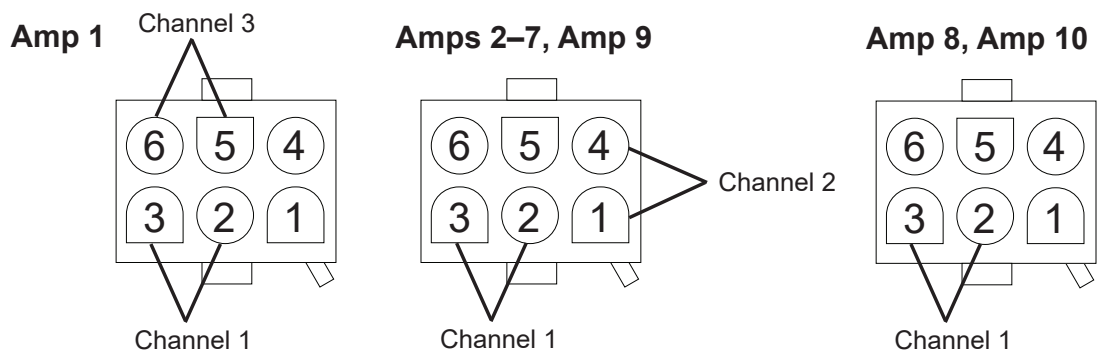

Figure 22: Harness Connector Pinout

Driver Replacement

High-Frequency Driver (A-2302)

Tools Required: flathead screwdriver, #2 screwdriver, 10mm wrench, utility knife, silicone

1. Remove the right-most rear access door using the flathead screwdriver.
2. Remove the internal speaker cabinet's back panel:
 - a. If there is a silicone seal, cut it with a utility knife.
 - b. Remove all screws with #2 screwdriver.
 - c. If there is an amplifier connected to the back panel, disconnect the harness, and then pull the internal cabinet panel off.
3. Identify bad driver(s) by following **Driver Troubleshooting (p.17)**.
4. Remove the bad driver(s):
 - a. Disconnect wires, if not already done.
 - b. Remove 4 threaded studs with the 10mm wrench.
 - c. Pull off the bad driver (**Figure 23**).
5. Install replacement driver:
 - a. Hand tighten shorter threaded end of studs into driver.
 - b. Align driver with screw holes.
 - c. Fasten nuts to 4 threaded studs with 10mm wrench.
 - d. Reconnect wires, making sure positive and negative go to correct terminals.
6. Reinstall internal speaker cabinet's back panel.
 - a. Align panel and fasten all screws with #2 screwdriver.
 - b. Re-seal the perimeter with silicone, if it was cut.
7. Reinstall rear access door.
8. Test the system to verify it is operating correctly per **System Testing (p.17)**.

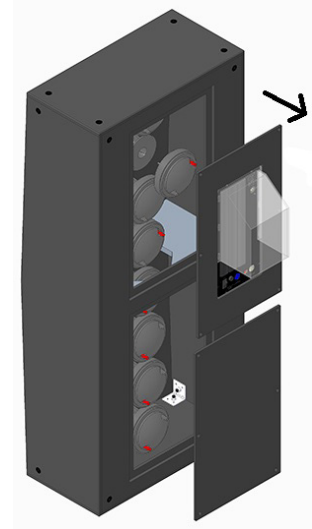

Figure 23: A-2302 Removal

Mid-Frequency Driver (A-2305)

Tools Required: flathead screwdriver, 5/32 Allen wrench, 3/16 Allen wrench, 10mm wrench, utility knife, silicone

1. Remove the center rear access door using the flathead screwdriver.
2. Remove the internal speaker cabinet's back panel:
 - a. If there is a silicone seal, cut it with a utility knife.
 - b. Remove all screws with 5/32 Allen wrench.
 - c. Pull the internal cabinet panel off.
3. Identify bad driver(s) by following **Driver Troubleshooting (p.17)**.
4. Remove bad driver(s):
 - a. Disconnect wires, if not already done, taking note of positive and negative wire location.
 - b. Remove 4 screws with 3/16 Allen wrench.
 - c. Pull off bad driver (**Figure 24**).
5. Install replacement driver:
 - a. Align driver with screw holes.
 - b. Fasten 4 screws with 3/16 Allen wrench.
 - c. Reconnect wires, making sure positive and negative go to correct terminals.
6. Reinstall internal speaker cabinet's back panel.
 - a. Align panel and fasten all screws with 5/32 Allen wrench.
 - b. Re-seal the perimeter with silicone, if it was cut.
7. Reinstall rear access door.
8. Test the system to verify it is operating correctly per **System Testing (p.17)**.

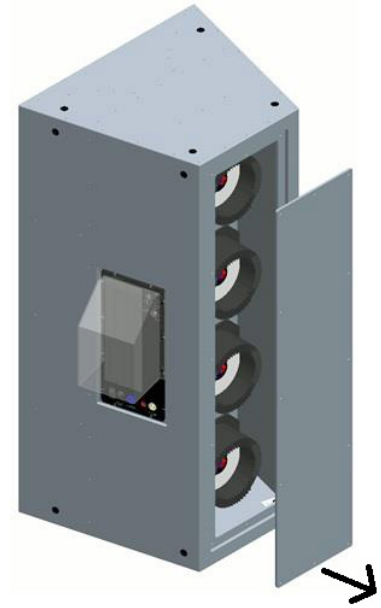

Figure 24: A-2305 Removal

Low-Frequency Driver (A-2306)

Tools Required: flathead screwdriver, 5/32 Allen wrench, 3/16 Allen wrench, utility knife, silicone

1. Remove the left-most rear access door using the flathead screwdriver.
2. Remove the internal speaker cabinet's back panel:
 - a. If there is a silicone seal, cut it with a utility knife.
 - b. Remove all screws with 5/32 Allen wrench.
 - c. If there is an amplifier connected to the back panel, disconnect the harness, and then pull the internal cabinet panel off.
3. Identify bad driver(s) by following **Driver Troubleshooting (p.17)**.
4. Remove the bad driver(s):
 - a. Disconnect wires, if not already done.
 - b. Remove 8 screws with the 3/16 Allen wrench.
 - c. Pull off the bad driver (**Figure 25**).
5. Install replacement driver:
 - a. Align driver with screw holes.
 - b. Fasten 8 screws with 3/16 Allen wrench.
 - c. Reconnect wires, making sure positive and negative go to correct terminals.
6. Reinstall internal speaker cabinet's back panel.
 - a. Align panel and fasten all screws with 5/32 Allen wrench.
 - b. Re-seal the perimeter with silicone, if it was cut.
7. Reinstall rear access door.
8. Test the system to verify it is operating correctly per **System Testing (p.17)**.

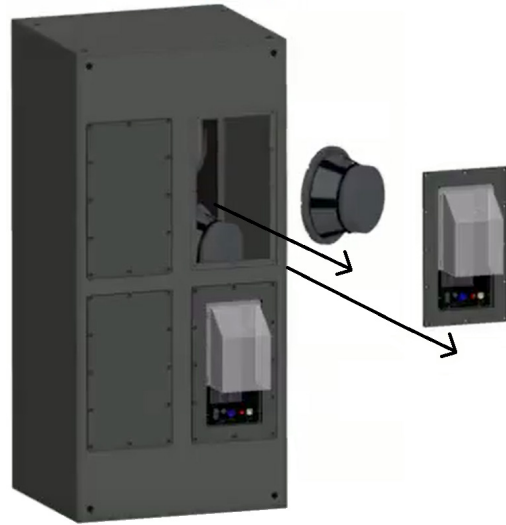

Figure 25: A-2306 Removal

Note: For 2000HD cabinets manufactured prior to April 2014, the low frequency drivers must be replaced from the front; there are no internal back panels to access the drivers from the rear.

Amplifier Troubleshooting and Replacement

Tools Required: #2 Phillips screwdriver, flathead screwdriver

1. Remove one or more rear access doors using the flathead screwdriver.
2. Locate the defective amplifier:
 - a. Refer to **System Testing (p.17)** for basic amplifier troubleshooting, or refer to the **Sportsound Amplifier Field Guide (DD3318172)**, available online at www.daktronics.com/manuals, for more detailed troubleshooting procedures.
 - b. Once it has been determined that there is a defective amplifier, contact Daktronics to order a replacement.

3. Verify the new amplifier is the correct replacement for the defective amplifier. Check the label (**Figure 26**) on the new amplifier to verify that the **Part Number** matches the table below and that the **Config** matches the label on the defective amplifier.

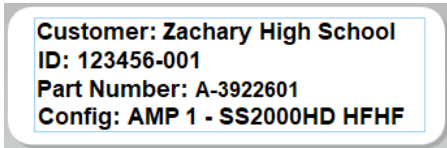

Figure 26: Amp Label

Product	Legacy Amp Part #	New Amp Part #	Amplifier Label	Quantity
2000HD	A-2538*	A-3922601	AMP1 HFHF	1
	A-2470*, A-2538*	A-3922601	AMP2-AMP6 MFHF	5
	A-2470*, A-2538*	A-3922601	AMP7, AMP9 LFLF	2
	A-2469*, A-2538*	A-3922601	AMP8, AMP10 LF	2

* These amplifiers will be replaced by the corresponding new amplifier part number.

4. Remove the defective amplifier:
 - a. Use a #2 screwdriver to remove the machine screws securing the amplifier.
 - b. Carefully pull out on the amplifier, taking care not to break any cables inside the cabinet. A flathead screwdriver may be needed to pry the amplifier loose.
 - c. Unplug all power and signal cables.
 - d. Unplug the 6-pin connector from the rear of the amplifier.
5. Install the new amplifier:
 - a. Verify existing weather stripping is present. If not, install new weather stripping.
 - b. Verify all wires are still connected to the 6-pin connector and plug it into the rear of the amplifier.
 - c. Reconnect all power and signal cables.
 - d. Position the amplifier and use a #2 screwdriver to reinstall the machine screws. Be careful to not over-tighten the screws or the plastic hood could crack.
6. Follow the **Sportsound Amplifier Field Guide (DD3318172)** to verify that the correct firmware has been loaded by Daktronics Customer Service. All amplifiers present should have the firmware verified and updated to the most current version available.
7. Refer to **System Testing (p.17)** to verify replacement amplifier is working correctly.

Media Converters

In standard audio systems, there are two media converter/network switches, one in the fiber box and one in the control enclosure, that transfer digital audio signal. Looking at the connections and LED indicators on these devices help with system troubleshooting.

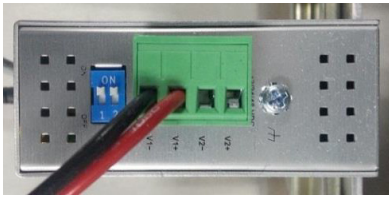

Figure 27: Power & BSP Switches

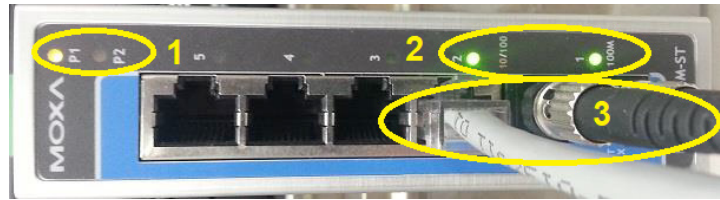

Figure 28: LED Indicators & Signal Connections

Typical Component Settings

- Ensure power is connected to green terminal block (Red to V1+, Black to V1-) and the two BSP DIP switches are both set to ON. Refer to **Figure 27**.
- Verify fiber cables are connected to RX and TX. Refer to **Figure 28-3**.
- Verify Ethernet cable connection(s) from other equipment. Typical connections for standard systems are as follows:
 - Fiber Conversion Box: 1 connection to ADC1; see **Input/Output Expander (p.24)**
 - Audio Cabinet Control Enclosure: 10 connections, one for each amplifier

Verifying Network Activity

- **P1 LED** will light amber to indicate the switch has power. Refer to **Figure 28-1**. If this LED does not light:
 - Verify proper connections to power supply (Red to V1+, Black to V1-).
 - Verify power supply is supplying 24 VDC.
 - Try connecting power to V2 inputs (Red to V2+, Black to V2-), and verify P2 lights.
- **Port 1 (100M) LED** will light solid green to indicate a functional connection between the fiber box and control enclosure (switch to switch). Refer to **Figure 28-2**. If this LED does not light:
 - Switch fiber pairs at the fiber conversion box.
 - Test fiber cable, and terminate as necessary.
 - Remove fiber jumpers.
 - Verify power and connectivity at the other end of the switch.
 - If still not lighting, replace the switch.
- Each Ethernet jack also has an LED that will light green when a cable to other equipment is connected. Refer to **Figure 28-2**. If these LEDs are not lighting:
 - Check Ethernet cable/connections.
 - Verify connection on opposite end of Cat5e cable.
 - Connect known working cable and equipment (such as a diagnostic laptop).
 - If still not lighting, replace the switch.

Input/Output Expander

The fiber box features an input/output expander that converts the analog audio signal from the control rack into a digital audio signal that can be sent over a local network. Looking at the connections and LED indicators on these devices help with system troubleshooting.



Figure 29: Network Activity & Analog Input

Typical Component Settings

Use the rotary dial and LCD screen to verify the following settings:

- Bundle # TX = 00001
- Bundle # RX = 00000 (default)
- CobraNet Latency = 5.33ms (default)
- Input Gain CH1 = +12 dBu
- Input Gain CH2 = 0 dBu (default)
- Phantom Power = OFF (default)
- Output Gain CH1 & CH2 = 0 dBu (default)
- Password Protect = UNLOCK (default) – **If accidentally password locked:** power down, hold in rotary dial button, power on, wait for screen to display Audia, let go of button; this resets the settings to factory defaults
- Title Display = AUDIA EXPI/O 2 (default)

Verifying Network Activity

Look at the bottom left corner of the Ethernet port for LED identification (**Figure 29-1**).

- Consistent flashing about 6 times a second = Device has a CobraNet connection to amplifiers. This is proper working state.
- Intermittent flashing about 1 time per second, or solid green light = Connected to a switch, but no CobraNet connection to amplifiers. There must be a connection to continue troubleshooting!
- No lights = Not connected to a switch.

Checking for Input Signal

Caution! Ensure sound cabinet is OFF during this test or damage to drivers will occur!

Output a 1 kHz sine wave between 0.5 VAC–1 VAC from the mixer (go to <http://dakfiles.daktronics.com/downloads/Audio/CD Test Tones/1kHz Sine Wave.wav>). Measure the AC Voltage with a digital multi-meter placed between the positive and negative terminals of the male XLR connector. If the level is above or below the listed range, adjust it using the mixer's channel and master faders. Next, measure the AC Voltage at the input of the terminal block between the positive and negative terminals (**Figure 29-2**). If it reads the same, the device is getting proper signal; if it reads different, there is a wiring issue.

Checking for Output Signal

Ensure the fiber box **ANALOG BACKUP** switch is set to **DIGITAL (Figure 30)**, and then refer to **System Testing (p.17)**. If proper signal is being received at the amplifier input, the unit is functioning properly and should not need to be replaced.



Figure 30: Analog Backup Switch

Replacement Parts

Sound Cabinet

Description	Part Number
Voltage Surge Protector	A-1129
24 VDC Power Supply	A-2238
1.4" Compression Driver	A-2302
8" Midrange Driver	A-2305
12" Woofer	A-2306
Industrial Media Converter / Ethernet Switch, 16 Port	A-2466
Power Amplifier, SP2-1200-1200	A-3922601
Transformer; Audio Input, 1 Channel	T-1130
RFI Line Filter, 20 Amp	Z-1007
2000HD Mesh Replacement Kit	0A-1340-2032
Tension Clip w/ Mandrel	HS-1613
Tensioning Tool	TH-1175

Fiber Conversion Box

Description	Part Number
24 VDC Power Supply	A-2238
Industrial Media Converter / Ethernet Switch, 5 Port	A-2580
Converter; Analog to Digital with CobraNet	A-2898

Refer to **Section 7: Daktronics Exchange and Repair & Return Programs (p.26)** for information on exchanging or returning parts.

7 Daktronics Exchange and Repair & Return Programs

Exchange Program

The Daktronics Exchange Program is a service for quickly replacing key components in need of repair. If a component fails, Daktronics sends a replacement part to the customer who, in turn, returns the failed component to Daktronics. This decreases equipment downtime. Customers who follow the program guidelines explained below will receive this service.

Before contacting Daktronics, identify these important numbers:

Model Number: _____

Job/Contract Number: _____

Date Manufactured/Installed: _____

Daktronics Customer ID Number: _____

To participate in the Exchange Program, follow these steps:

1. Call Daktronics Customer Service.

United States & Canada: 1-800-DAK-TRON (325-8766)

Outside the U.S. & Canada: +1-605-275-1040

2. When the new exchange part is received, mail the old part to Daktronics.

If the replacement part fixes the problem, send in the problem part being replaced.

- a. Package the old part in the same shipping materials in which the replacement part arrived.
- b. Fill out and attach the enclosed UPS shipping document.
- c. Ship the part to Daktronics.

3. The defective or unused parts must be returned to Daktronics within 5 weeks of initial order shipment.

If any part is not returned within five (5) weeks, a non-refundable invoice will be presented to the customer for the costs of replenishing the exchange parts inventory with a new part. Daktronics reserves the right to refuse parts that have been damaged due to acts of nature or causes other than normal wear and tear.

Repair & Return Program

For items not subject to exchange, Daktronics offers a Repair & Return Program. To send a part for repair, follow these steps:

1. Call Daktronics Customer Service.

United States & Canada: 1-800-DAK-TRON (325-8766)

Outside the U.S. & Canada: +1-605-275-1040

2. Receive a case number before shipping.

This expedites repair of the part.

3. Package and pad the item carefully to prevent damage during shipment.

Electronic components, such as printed circuit boards, should be placed in an antistatic bag before boxing. Daktronics does not recommend using packing peanuts when shipping.

4. Enclose:

- name
- address
- phone number
- the case number
- a clear description of symptoms

5. Ship to:

Daktronics Customer Service

[Case #]

201 Daktronics Drive, Dock E

Brookings, SD 57006

Daktronics Warranty & Limitation of Liability

The Daktronics Warranty & Limitation of Liability is located at the end of this manual. The Warranty is independent of Extended Service agreements and is the authority in matters of service, repair, and operation.

This page intentionally left blank.

A Reference Drawings

Refer to **Resources (p.1)** for information regarding how to read the drawing number. Any contract-specific drawings take precedence over the general drawings.

Reference Drawings:

Harness; LF Speaker Assy; SS1500HD/SS2000HD	DWG-374493
Harness; MF Speaker Assy; 1500HD/2000HD	DWG-384426
Harness; HF Speaker Assy; SS2000HD	DWG-384731
Shop Drawing; Sound System; 2000HD	DWG-330901
Mesh Layout; 2000HD Gen II	DWG-983337
System Riser; 2000HD	DWG-984140
System Riser; Electrical & Audio Notes	DWG-985713
Speaker Adjustment Chart; 2000HD.....	DWG-1023805
Schematic; Control Enclosure/Sound Cabinet 2000HD.....	DWG-1082599
Audio; Sportsound, Fiber Box Schematic.....	DWG-1095894

This page intentionally left blank.

AMPLIFIER MOUNTS IN
TOP CUTOUT
A-2482 = AMP 3
A-2499 = AMP 7 & AMP 9

AMPLIFIER MOUNTS IN
BOTTOM CUTOUT
A-2482 = AMP 4
A-2499 = AMP 8 & AMP 10

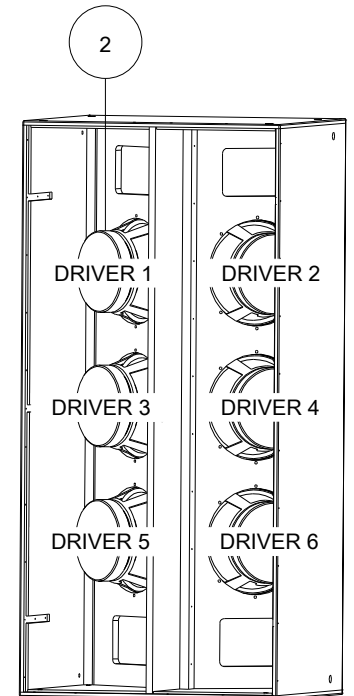
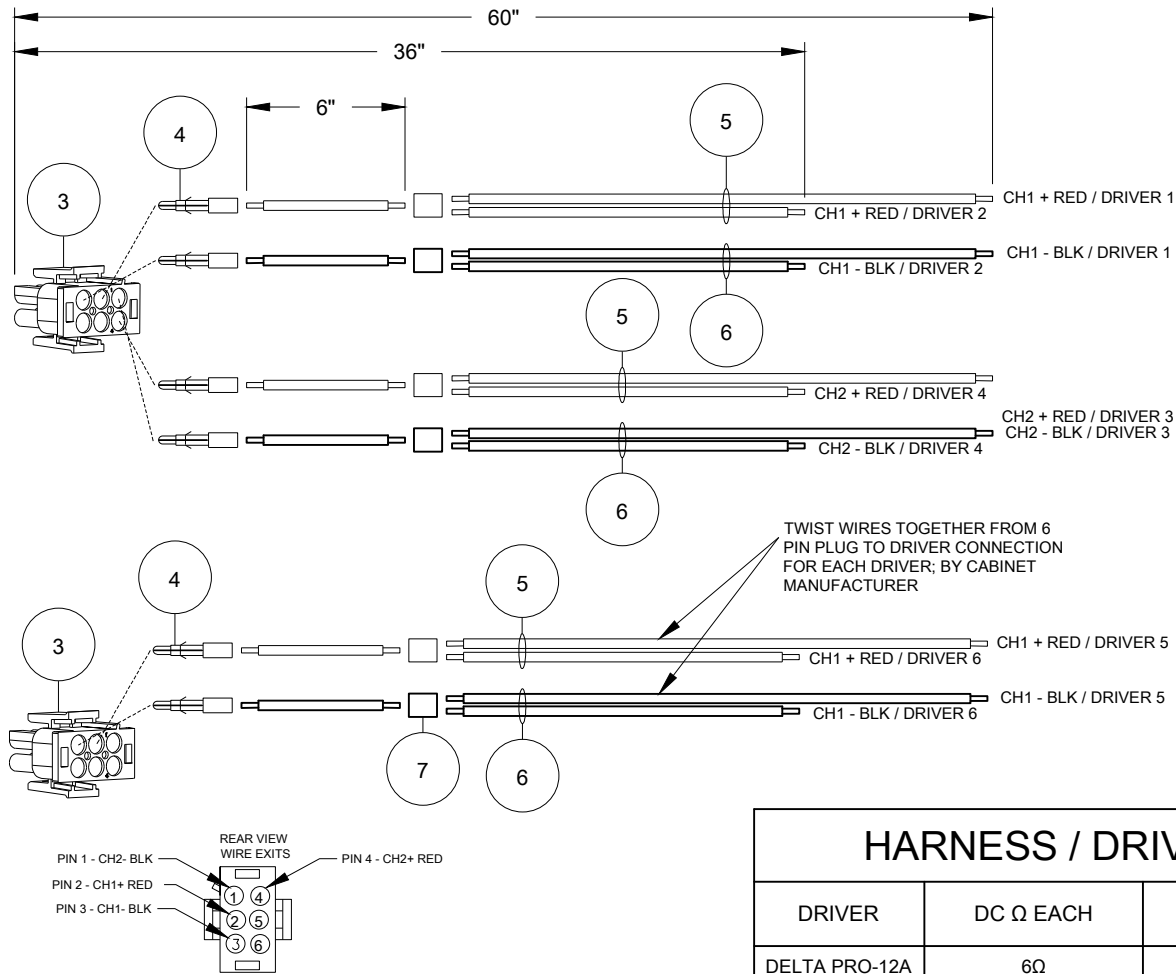

HARNESS / DRIVER TESTING

DRIVER	DC Ω EACH	TOTAL Ω AT MATE-N-LOK
DELTA PRO-12A	6Ω	3Ω AT PINS 2-3 AND 1-4

A-2482 / A-2499 BOM TABLE

ITEM	QTY	UNITS	DAK PART #	DESCRIPTION	PREFERRED MFGR	PART #
1	2	EA	A-3922601	2CH AMPLIFIER	SPEAKERPOWER	SP2-1200-1200-CN
2	6	EA	A-2306	12" DRIVER	EMINENCE	DELTA PRO-12A
3	2	EA	P-1348	6 PIN MATE-N-LOK PLUG	TYCO	1-480704-0
4	6	EA	E-1060	PIN, MATE-N-LOK, UMNL	TYCO	350922-3
5	288	IN		16 AWG, RED,		
6	288	IN		16 AWG, BLK		
7	6	EA		WIRE SPLICE	FASTENAL	FAS-60073

REV	DATE	DESCRIPTION	BY
08	31 JUL 18	2CH AMP A-2538 TO A-3922601 SEE REV 07 FOR OLDER REVISION HISTORY	CJB
07	17 OCT 17	ADDING AMPLIFIER LOCATION NOTES	CJB
06	29 JUL 15	PER EC-13829; REPLACED ALL AMPLIFIERS WITH A-2538 IN APRIL 2014	MKD
05	07 MAY 13	ADDED MORE DETAIL ADDED DRIVER RESISTANCE VALUES AND PART INDEX	TH



THE CONCEPTS EXPRESSED AND DETAILS SHOWN ON THIS DRAWING ARE CONFIDENTIAL AND PROPRIETARY. DO NOT REPRODUCE BY ANY MEANS WITHOUT THE EXPRESS WRITTEN CONSENT OF DAKTRONICS, INC. OR ITS WHOLLY OWNED SUBSIDIARIES. COPYRIGHT 2017 DAKTRONICS, INC. (USA)

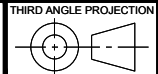

PROJECT: SPORTSOUND SYSTEMS		SHEET		REV
TITLE: HARNESS; LF SPEAKER ASSY; SS1500HD/SS2000HD				08
DATE: 16 MAR 08	DIM UNITS: INCHES [MILLIMETERS]			
SCALE: NONE	DO NOT SCALE DRAWING			
DESIGN: JAH	JOB NO. P1340	FUNC - TYPE - SIZE R - 10 - A		
DRAWN: JAH				374493

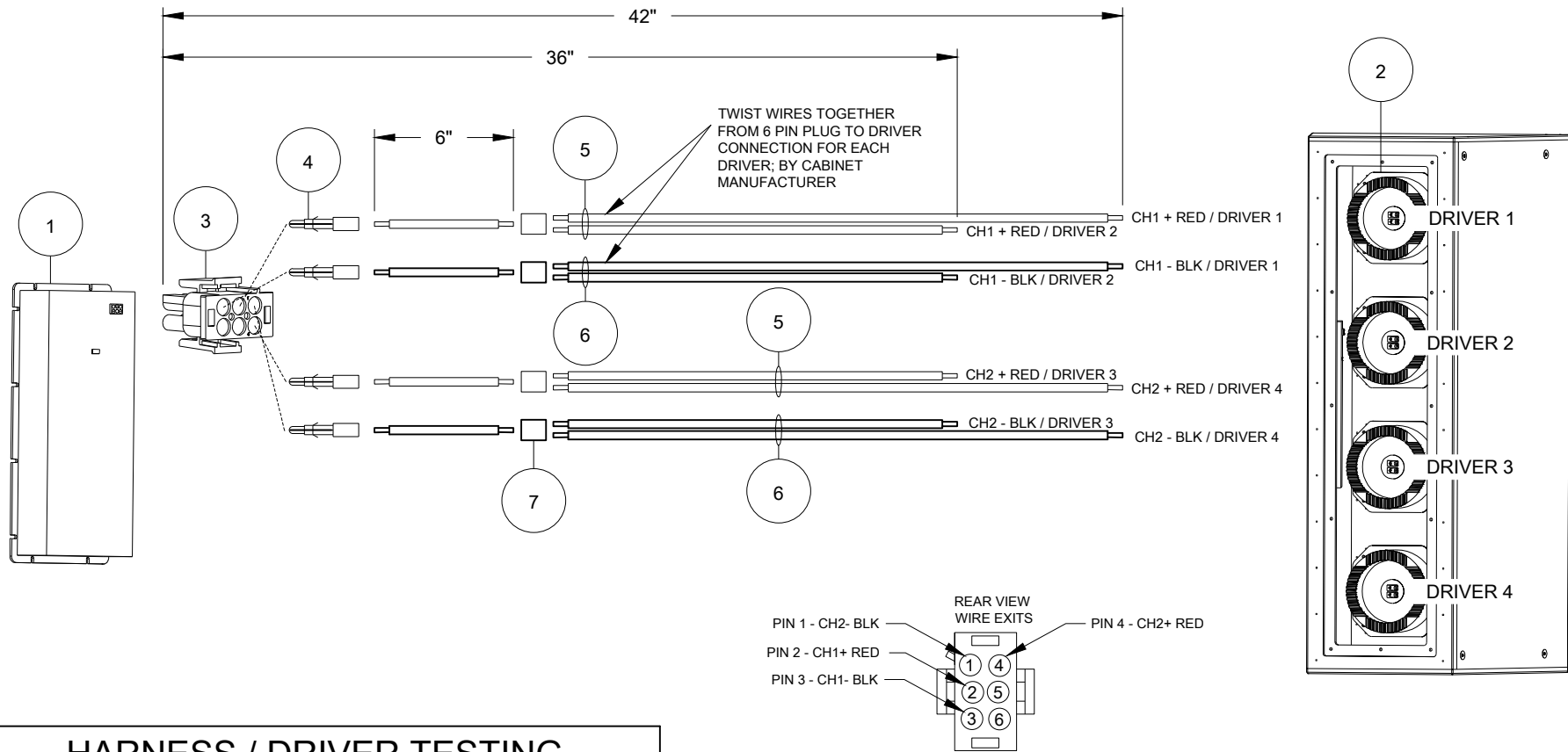

HARNESS / DRIVER TESTING		
DRIVER	DC Ω EACH	TOTAL Ω AT MATE-N-LOK
RCF MR8N301	6.6Ω	3.2Ω AT PINS 2-3 AND 1-4

A-2483 / A-2500 BOM TABLE						
ITEM	QTY	UNITS	DAK PART #	DESCRIPTION	PREFERRED MFGR	PART #
1	1	EA	A-3922601	2CH AMPLIFIER	SPEAKERPOWER	SP2-1200-1200-CN
2	4	EA	A-2305	8" SEALED BACK DRIVER	RCF	MR8N301
3	1	EA	P-1348	6 PIN MATE-N-LOK PLUG	TYCO	1-480704-0
4	4	EA	E-1060	PIN, MATE-N-LOK, UMNL	TYCO	350922-3
5	198	IN		16 AWG, RED,		
6	198	IN		16 AWG, BLK		
7	4	EA		WIRE SPLICE	FASTENAL	FAS-60073

REV 07	DATE: 1 AUG 18	2CH AMP A-2538 TO A-3922601 SEE REV 06 FOR EARLIER REVISION HISTORY	BY: CJB
REV 06	DATE: 29 JUL 15	PER EC-13829; REPLACED ALL AMPLIFIERS WITH A-2538 IN APRIL 2014	BY: MKD
REV 05	DATE: 02 MAY 13	ADDED MORE DETAIL ADDED DRIVER RESISTANCE VALUES AND PART INDEX	BY: TH
REV 04	DATE: 25 JAN 13	ADDED BUTT SPLICE AND NOTE PER EC-9203	BY: JDP

DAKTRONICS THE CONCEPTS EXPRESSED AND DETAILS SHOWN ON THIS DRAWING ARE CONFIDENTIAL AND PROPRIETARY. DO NOT REPRODUCE BY ANY MEANS WITHOUT THE EXPRESS WRITTEN CONSENT OF DAKTRONICS, INC. OR ITS WHOLLY OWNED SUBSIDIARIES. COPYRIGHT 2018 DAKTRONICS, INC. (USA)

THIRD ANGLE PROJECTION

PROJECT: SPORTSOUND SYSTEMS
 TITLE: HARNESS; MF SPEAKER ASSY: 1500HD/2000HD
 DATE: 3 APR 08 DIM UNITS: INCHES [MILLIMETERS] SHEET REV
 SCALE: 1=1 DO NOT SCALE DRAWING 07
 DESIGN: JAH0 JOB NO. FUNC - TYPE - SIZE
 DRAWN: JAH0 P1340 R - 10 - A

384426

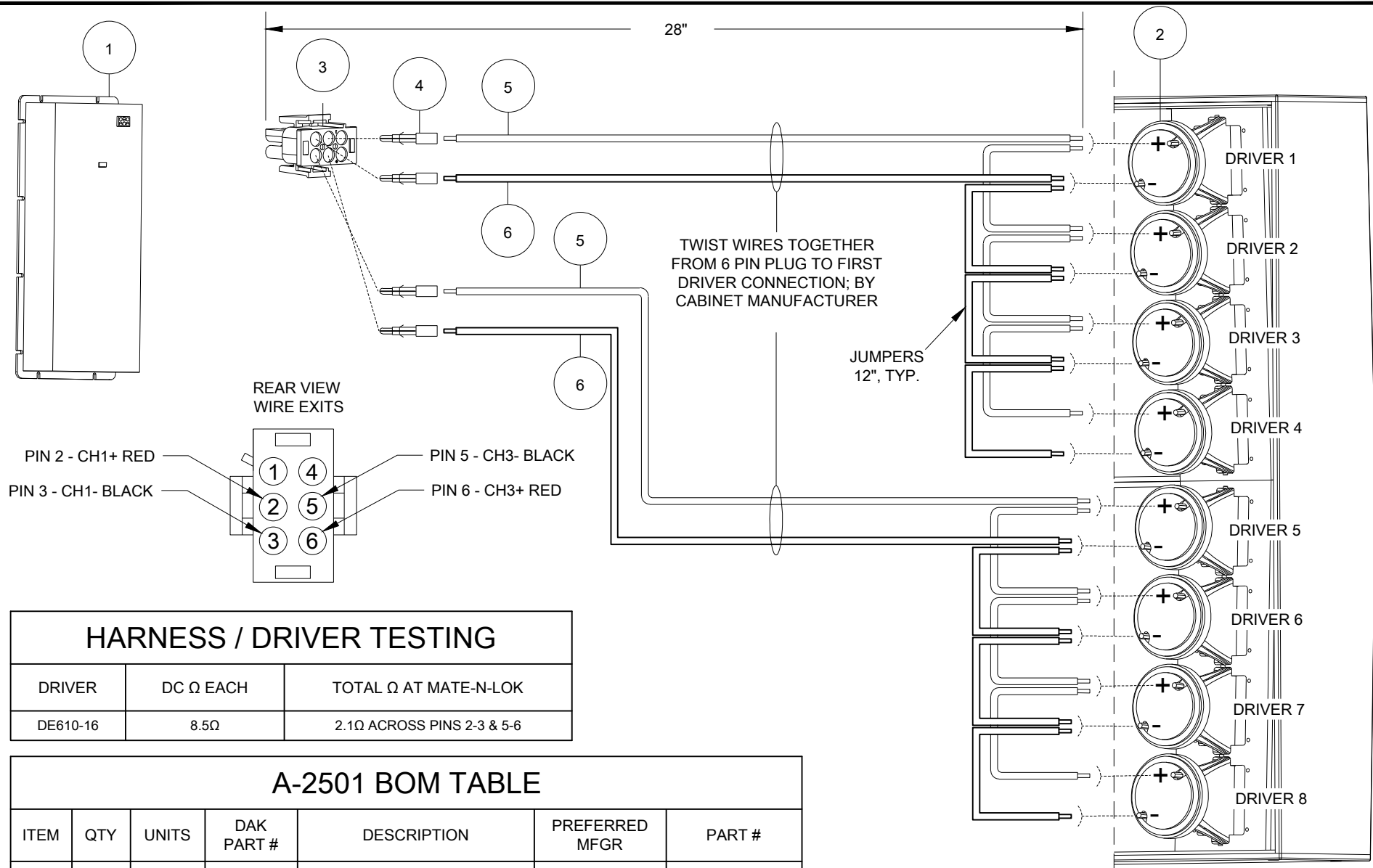

HARNESS / DRIVER TESTING

DRIVER	DC Ω EACH	TOTAL Ω AT MATE-N-LOK
DE610-16	8.5 Ω	2.1 Ω ACROSS PINS 2-3 & 5-6

A-2501 BOM TABLE

ITEM	QTY	UNITS	DAK PART #	DESCRIPTION	PREFERRED MFGR	PART #
1	1	EA	A-3922601	2CH AMPLIFIER	SPEAKERPOWER	SP2-1200-1200-CN
2	8	EA	A-2302	1.4" EXIT COMPRESSION DRIVER	B&C	DE610-16
3	1	EA	P-1348	6 PIN MATE-N-LOK PLUG	TYCO	1-480704-0
4	4	EA	E-1060	PIN, MATE-N-LOK, UMNL	TYCO	350922-3
5	128	IN		16 AWG, RED,		
6	128	IN		16 AWG, BLK		

REV	DATE	DESCRIPTION	BY
08	2 AUG 18	2CH AMP A-2538 TO A-3922601 SEE REV 07 FOR OLDER REVISION HISTORY	CJB

THE CONCEPTS EXPRESSED AND DETAILS SHOWN ON THIS DRAWING ARE CONFIDENTIAL AND PROPRIETARY. DO NOT REPRODUCE BY ANY MEANS WITHOUT THE EXPRESS WRITTEN CONSENT OF DAKTRONICS, INC. OR ITS WHOLLY OWNED SUBSIDIARIES. COPYRIGHT 2018 DAKTRONICS, INC. (USA)

THIRD ANGLE PROJECTION

PROJECT: SPORTOUSND SYSTEMS

TITLE: HARNESS; HF SPEAKER ASSY: SS2000HD

DATE: 4 APR 08 DIM UNITS: INCHES [MILLIMETERS] SHEET REV

SCALE: 1=1 DO NOT SCALE DRAWING 08

DESIGN: JAH0 JOB NO. FUNC - TYPE - SIZE

DRAWN: JAH0 P1340 R - 10 - A

384731

This page intentionally left blank.

SPORTSOUND 2000HD

STANDARD SHOP

NOTES:

- 1.0 REFERENCE
- 1.1 REFER TO DAKTRONICS RISER DIAGRAM 1340-R10B-329134 FOR ALL ELECTRICAL POWER AND DATA SPECIFICATIONS.
- 1.2 THE SHOWN SYSTEM MUST BE APPROVED BY THE CUSTOMER AND ALL ATTACH-TO STRUCTURE MUST BE CERTIFIED IN THE STATE IN WHICH IT IS INSTALLED BY A QUALIFIED STRUCTURAL ENGINEER BEFORE FABRICATION OR ERECTION.
- 2.0 GENERAL NOTES
- 2.1 ALL DIMENSIONS ARE IN FEET AND INCHES.
- 2.2 REFER TO INSTALLATION AND MAINTENANCE MANUAL FOR COMPLETE INSTALLATION INSTRUCTIONS.
- 3.0 SOUND CABINET NOTES
- 3.1 DAKTRONICS SOUND CABINET IS STEEL CONSTRUCTED SKELETON WITH METAL PANELING FASTENED TO ITS EXTERIOR.
- 3.2 LIFT PLATES ARE PROVIDED BY DAKTRONICS. WHEN LIFTING USE 45° OR GREATER, FROM THE HORIZON, CABLE SYSTEM.
- 4.0 STRUCTURAL NOTES
- 4.1 ALL STRUCTURAL STEEL SHALL BE ASTM A36, EXCEPT: TUBING SHALL BE A500-B.
- 4.2 THE SOUND CABINET HAS BEEN DESIGNED TO WITHSTAND UP TO A *150MPH (3-SEC GUST) DESIGN WIND SPEED WITH AN OVERALL MAXIMUM DESIGN PRESSURE OF 88 PSF ACCORDING TO ASCE 7-05 (EXPOSURE C).
- 4.3 *REFER TO TABLE FOR MAXIMUM DISTANCE OF FRONT WELD CONNECTION.
- 4.4 THE DESIGN WIND PRESSURE WERE SHIFTED AND ADJUSTED TO ACCOUNT FOR ASCE 7 PRESCRIBED OFFSET EFFECTS.
- 4.5 THE SOUND CABINET HAS BEEN DESIGNED TO SUPPORT A FLOOR LIVE LOAD OF 90 PSF TO ACCOUNT FOR THE WEIGHT OF THE SPEAKERS AND ANY SERVICE PERSONNEL.
- 4.6 THE SOUND CABINET HAS BEEN DESIGNED TO SUPPORT A DESIGN ROOF SNOW LOAD OF 30 PSF.
- 4.7 THE SOUND CABINET HAS BEEN DESIGNED TO SUPPORT A LATERAL SEISMIC LOADING EQUAL TO 2.0 TIMES GRAVITY.
- 4.8 FABRICATION AND ERECTION SHALL CONFORM TO THE LATEST EDITION OF AISC SPECIFICATIONS.
- 4.9 ALL WELDING (SHOP AND FIELD) SHALL BE PERFORMED IN ACCORDANCE WITH AWS D1.1-LATEST EDITION SPECIFICATIONS BY A CERTIFIED WELDER USING E70XX ELECTRODES.
- 5.0 PROJECT RESPONSIBILITY
- 5.1 DAKTRONICS' AND CUSTOMER SUBCONTRACTORS SHALL VERIFY ALL EXISTING CONDITIONS AND DIMENSIONS PRIOR TO INSTALLATION.
- 5.2 ALL SUBCONTRACTORS SHALL PERFORM WORK IN ACCORDANCE WITH OSHA REQUIREMENTS AND ANY LOCAL CODES THAT APPLY.
- 5.3 EACH SUBCONTRACTOR IS SOLELY RESPONSIBLE FOR JOBSITE SAFETY.
- 5.4 ERECTION SUBCONTRACTOR IS SOLELY RESPONSIBLE FOR DESIGNING AND PROVIDING TEMPORARY BRACING.
- 5.5 EACH SUBCONTRACTOR IS RESPONSIBLE FOR THE REMOVAL AND DISPOSAL OF WASTE MATERIALS ON THE JOBSITE.

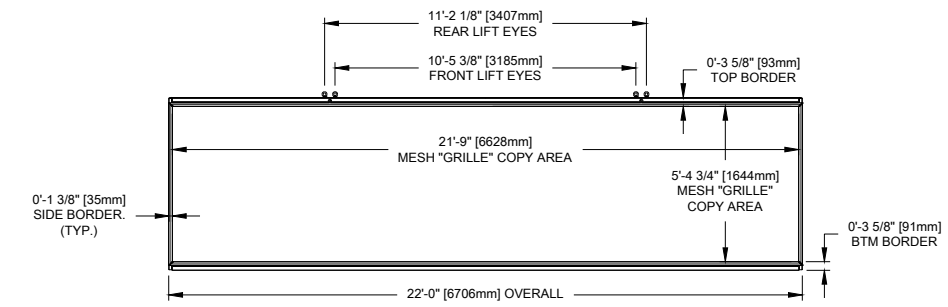
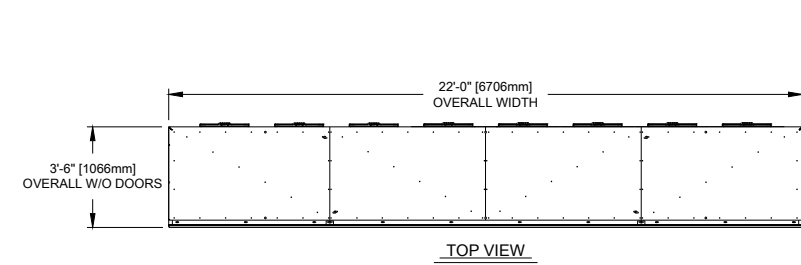

NOTE:
THE 2 LIFT EYES ON THE FRONT MESH FRAME SHOULD NOT BE USED WHEN LIFTING THE CABINET INTO POSITION. THESE ARE TO BE USED ONLY WHEN REMOVING THE MESH FRAME FROM THE CABINET FOR MAINTENANCE PURPOSES. LEAVE THESE 2 LIFT EYES ON THE MESH FRAME AFTER INSTALLATION IS COMPLETE.

FRONT "GRILLE" FRAME CAN BE REMOVED FOR SPEAKER MESH RE-INSTALLATION. (10) 3/8" HARDWARE SETS ON TOP & (10) 3/8" HARDWARE SETS ON BTM SECURE FRAME TO STEEL CABINET. "GRILLE" FRAME APPROX. 180 LBS.

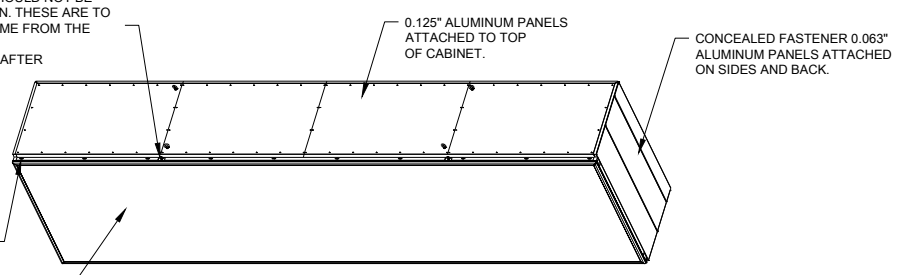

ACOUSTICAL MESH "GRILLE" ARTWORK TO BE APPROVED BY CUSTOMER.

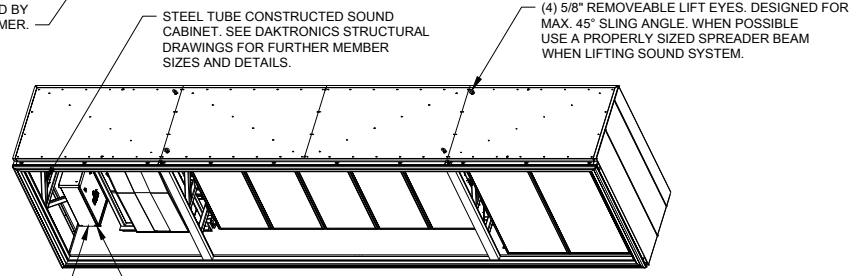

POWER IN LOCATION. 20 AMP 208-240VAC @3 REQUIRED

SPORTSOUND CONTROL ENCLOSURE. SPEAKER DATA IN LOCATION
(1) W-1614, AUDIO CABLE, 2 PAIR, 22AWG
(1) W-1489, FIBER CABLE, 6 CORE CABLE PROVIDED BY DAKTRONICS INSTALLED BY DAKTRONICS SUBCONTRACTOR.

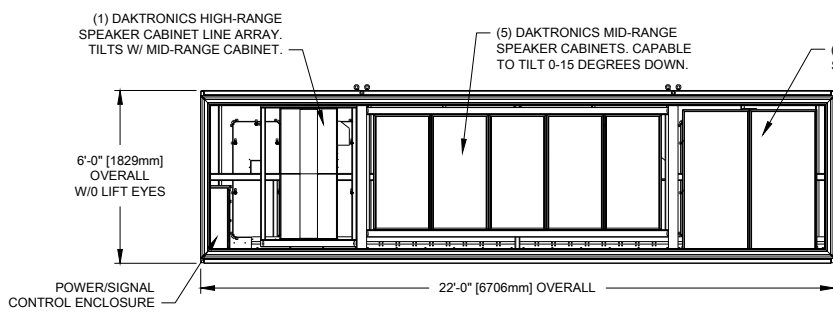

W/O MESH "GRILLE"

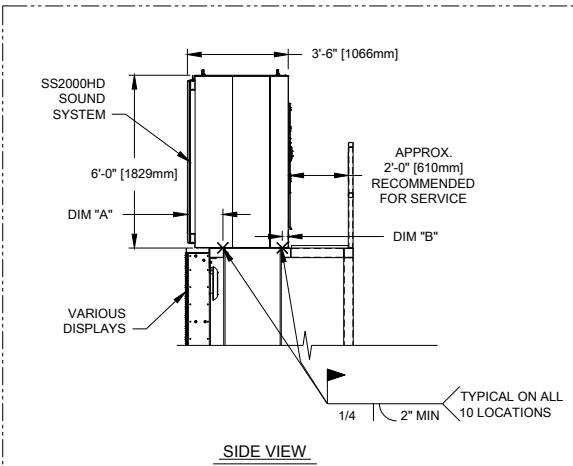
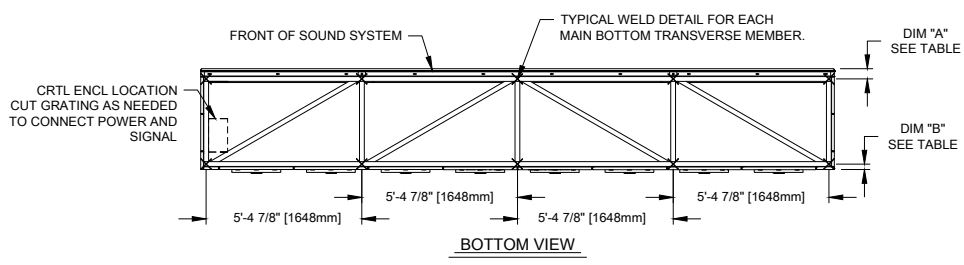
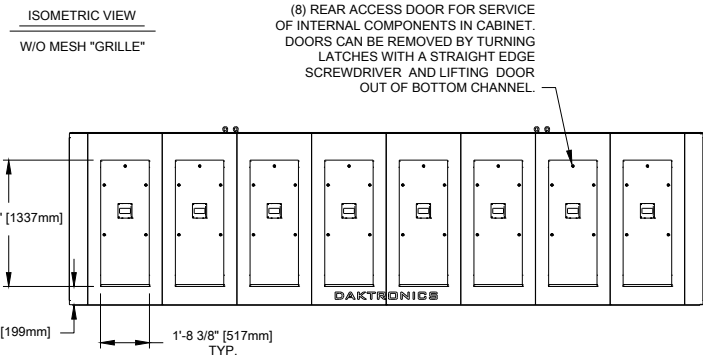
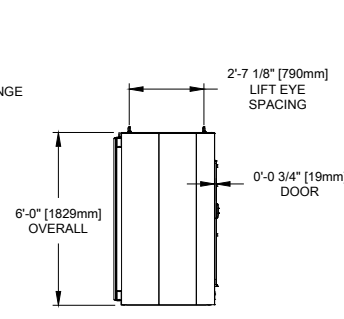

WIND SPEED (MPH)	DESIGN WIND PRESSURE (PSF)	DIM "A" (INCHES)	DIM "B" (INCHES)
90	32	19	10
110	47	17	5.5
130	66	14.5	3
150	88	7	3

NOTES:
DIM "A" REPRESENTS THE MAXIMUM DIMENSION FROM THE FRONT OF SOUND SYSTEM TO FRONT WELD LOCATION OF "ATTACH-TO STRUCTURE" PER DESIGN WIND PRESSURE.
DIM "B" REPRESENTS THE MAXIMUM DIMENSION FROM THE BACK OF SOUND SYSTEM TO BACK WELD LOCATION OF "ATTACH-TO STRUCTURE" PER DESIGN WIND PRESSURE.
THE "ATTACH-TO STRUCTURE" SHOWN IS FOR CONCEPTUAL PURPOSES ONLY. THE APPROPRIATE LOADING CONDITIONS AND THE SIZE OF THE "ATTACH-TO STRUCTURE" SHALL BE EVALUATED FOR EACH USE OF THIS SYSTEM AND IS NOT EVALUTED IN THIS DRAWING.

TOTAL SOUND SYSTEM WEIGHT: 4000 LBS

SUBMITTAL APPROVAL

APPROVED

APPROVED AS NOTED

APPROVED AS NOTED & RESUBMIT

COMPANY: _____

SIGNED: _____

TITLE: _____ DATE: _____

SHEET 502

DAKTRONICS, INC. BROOKINGS, SD 57008

THE CONCEPTS EXPRESSED AND DETAILS SHOWN ON THIS DRAWING ARE CONFIDENTIAL AND PROPRIETARY. DO NOT REPRODUCE BY ANY MEANS WITHOUT THE EXPRESSED WRITTEN CONSENT OF DAKTRONICS, INC. COPYRIGHT 2010 DAKTRONICS, INC.

REV	DATE	UPDATED REAR ACCESS DOOR VIEWS WITH NEW LATCH AND DOOR HANDLE	BY:	KCS
09	18 JUL 13			

PROJ	REV	JOB NO	FUNC-TYPE-SIZE	SHEET
SPORTSOUND SYSTEMS	001	P1340	E-10-C	330901

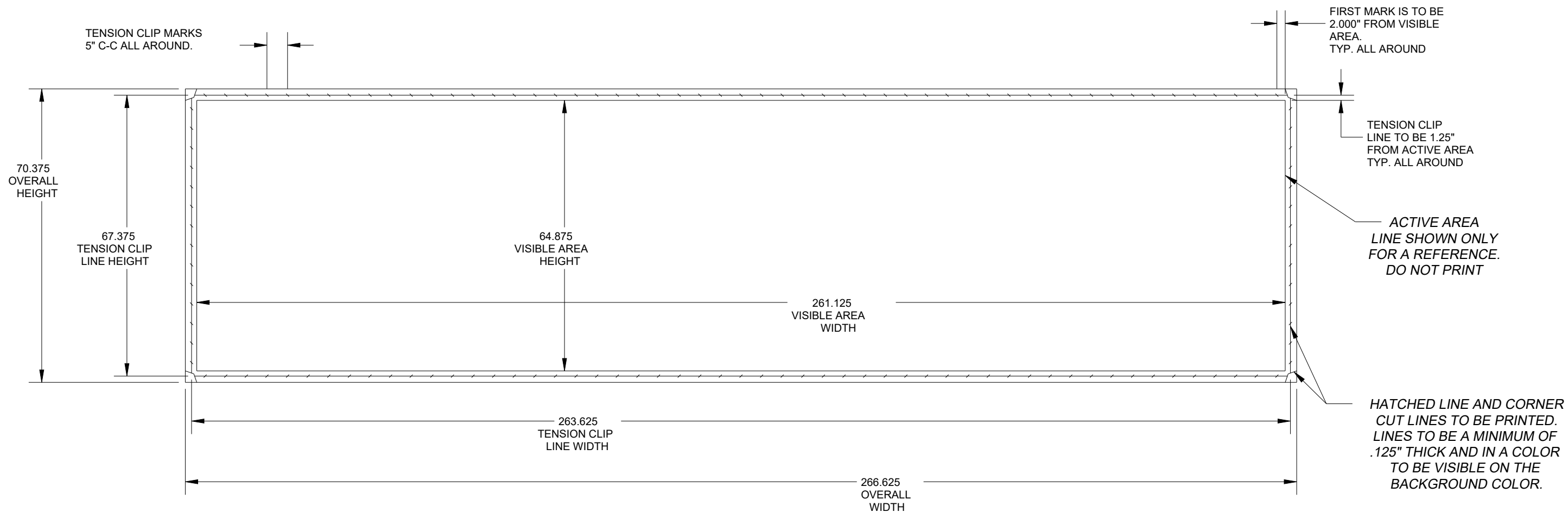

FRONT LAYOUT VIEW

NOTES:

1. OVERALL DIMENSIONS ARE CRITICAL TO +/- 1/8"
2. ALL DIMENSIONS ARE IN INCHES.
3. ACOUSTICAL MESH SHALL BE SEATTLE TEXTILE 5071, ULTRAFLEX ULTRAMESH SUPREME, OR APPROVED.
4. ACOUSTICAL MESH TO BE SEAMLESS
5. PROTECTIVE UV CLEAR COAT TO BE APPLIED TO MESH
6. BACKGROUND COLOR SHALL BE PRINTED ON ENTIRE MESH LENGTH AND HEIGHT.
7. ACOUSTICAL MESH TO BE SHIPPED IN TUBE. (DO NOT FOLD MESH)

05	18 JUN 13	MOVED HATCH LINES 1.75" CLOSER TO THE CORNERS PER EC-10967	KCS	
04	20 SEP 12	UPDATED NOTES WITH UV COATING AND SEAMLESS REQUIREMENTS.	KCS	
03	4 JUN 12	ADDED MESH PART NUMBER AND REV TO DRAWING CHANGED MESH SPEC TO ULTRAMESH SUPREME	KCS	
02	27 SEP 10	ADDED CORNER CUT LINES. INCREASED CORNER TICK MARK START DISTANCE FROM 3" TO 5". CHANGED HATCH SPACING TO 5" C-C.	KCS	
01	19 APR 10	CHANGED ACTIVE AREA TO HATCH LINE. DISTANCE FROM 1.5 TO 1.25. DECREASED OVERALL SIZE. 5" ALL AROUND.	KCS	
REV	DATE:		BY:	

DAK PART NUMBER: EN-2688

		THE CONCEPTS EXPRESSED AND DETAILS SHOWN ON THIS DRAWING ARE CONFIDENTIAL AND PROPRIETARY. DO NOT REPRODUCE BY ANY MEANS WITHOUT THE EXPRESSED WRITTEN CONSENT OF DAKTRONICS, INC. COPYRIGHT 2011 DAKTRONICS, INC.	
DO NOT SCALE DRAWING			
PROJ:	DAKTRONICS AUDIO SYSTEMS		
TITLE:	MESH LAYOUT; 2000HD GEN II		
DESIGN:	KSCHNABEL	DRAWN:	KSCHNABEL
SCALE:	1/25	DATE:	19-JUN-13
SHEET:	REV	JOB NO:	FUNC-TYPE-SIZE
1 OF 2	05	P 1340	E - 10 - B
			983337

ANNOUNCER'S LOCATION DETAILS

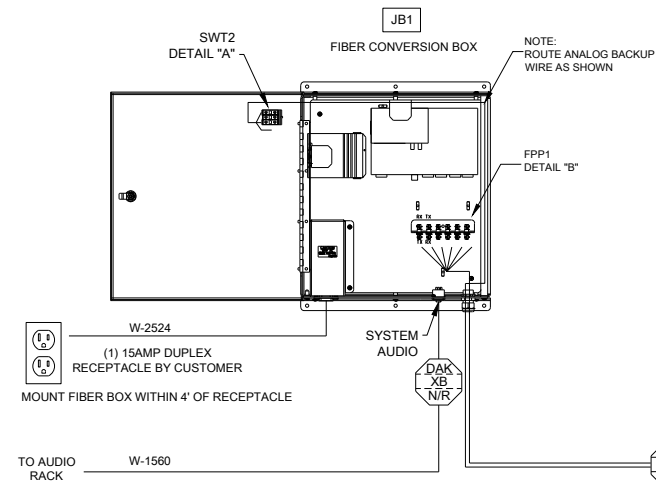

SIGN LOCATION DETAILS

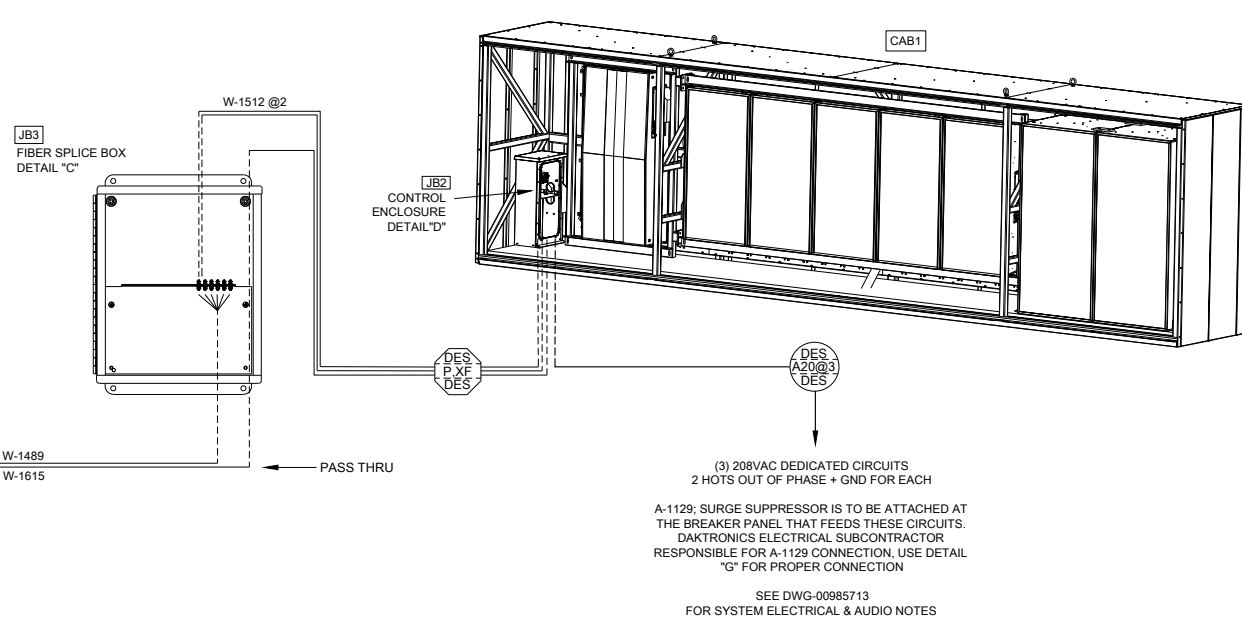

NOTE:
IF OTHER SURGE SUPPRESSION IS PROTECTING THE NECESSARY CIRCUITS, THE A-1129(S) IS/ARE OPTIONAL

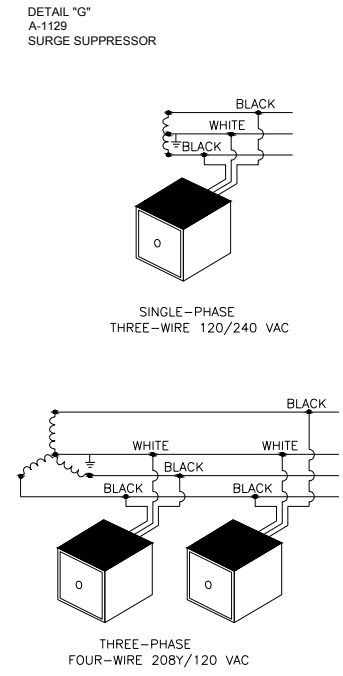

COMPONENT IDENTIFICATION LEGEND				
COMPONENT	DESCRIPTION	MANUFACTURE'S #	PROVIDED BY	INSTALLED BY
JB1	ANALOG BACKUP FIBER BOX	0A-1534-0060	DAKTRONICS	OTHERS
CAB1	2000HD SERIES CABINET	0A-1340-2021	DAKTRONICS	OTHERS
JB2	CONTROL ENCLOSURE	0A-1340-2039	DAKTRONICS	DAKTRONICS
JB3	FIBER SPLICE BOX	0A-1534-0057	DAKTRONICS	DAKTRONICS
WIRE TAGS	DETAILS FOR WIRE TAGS	DWG-985713	DAKTRONICS	-

CIRCUIT 1 TOTAL POWER REQUIREMENTS:		CIRCUIT 2 TOTAL POWER REQUIREMENTS:		CIRCUIT 3 TOTAL POWER REQUIREMENTS:	
SYSTEM VOLTAGE	208/230/240	SYSTEM VOLTAGE	208/230/240	SYSTEM VOLTAGE	208/230/240
NUMBER OF WIRES	2 WIRES + GND	NUMBER OF WIRES	2 WIRES + GND	NUMBER OF WIRES	2 WIRES + GND
NUMBER OF POLES	2	NUMBER OF POLES	2	NUMBER OF POLES	2
MAXIMUM WATTS	1310W	MAXIMUM WATTS	3340W	MAXIMUM WATTS	2500W
AMPERES PER LINE	6.3A	AMPERES PER LINE	16A	AMPERES PER LINE	12A

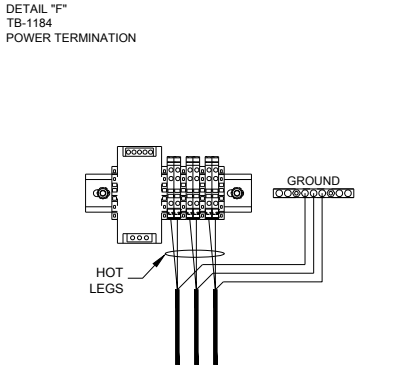
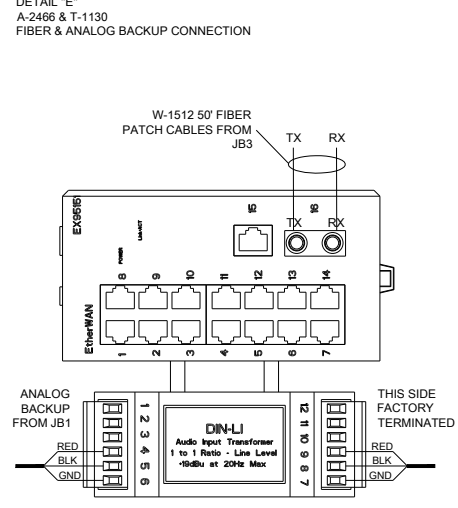
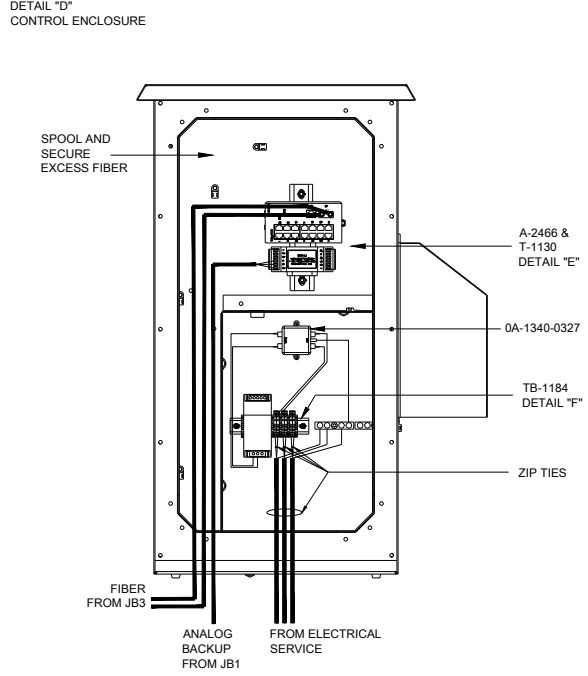
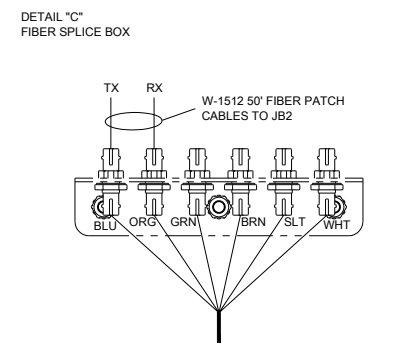
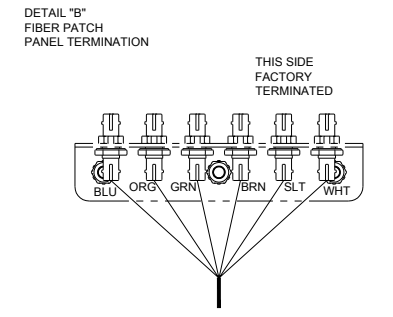
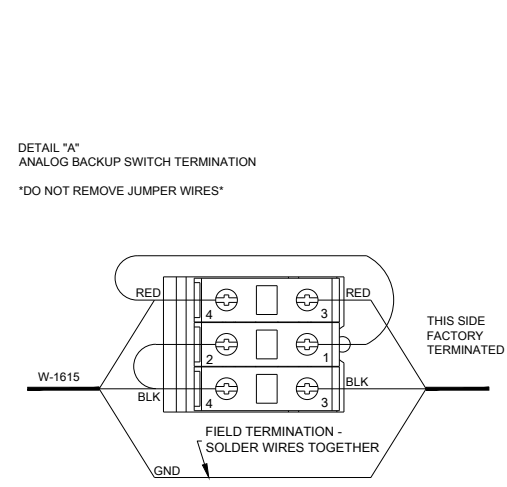

REV	DATE	ADDED NOTE TO DETAIL "G"	BY
06	5 FEB 13		CJB
05	29 OCT 12	ADDED 0A-1340-0327	CJB
04	20 JAN 12	CHANGED DWG FROM B TO C ADJUSTED LAYOUT AND UPDATED POWER DETAILS ALSO ADDED FIBER SPLICE BOX	DCS
03	03 JUN 11	ADDED DETAILS "A" - "E"	AMS
02	21 DEC 10	CHANGED 2 STRAND FIBER TO 8 STRAND FIBER	CJB
01	18 MAY 10	ADDED ANALOG BACKUP CABLE BETWEEN JB1 & JB2	APL

DAKTRONICS, INC.
BROOKINGS, SD 57008

PROJ: SPORTSOUND SYSTEMS
TITLE: SYSTEM RISER, 2000HD
DESIGN: ALICHT
SCALE: NONE

SHEET: 06
JOB NO: P1340
REV: 06
DATE: 13 APR 10
FUNC-TYPE-SIZE: R-01-C
984140

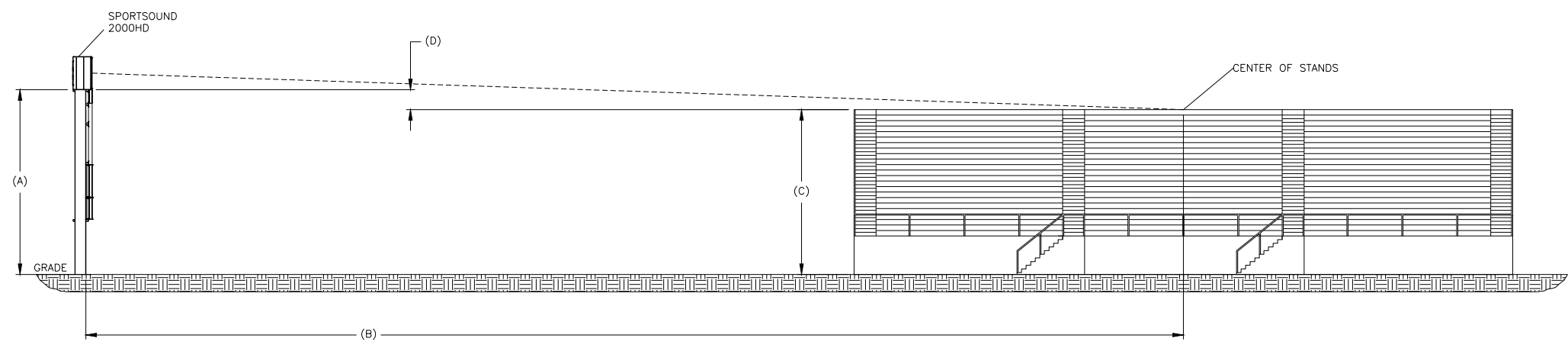

ELEVATION VIEW

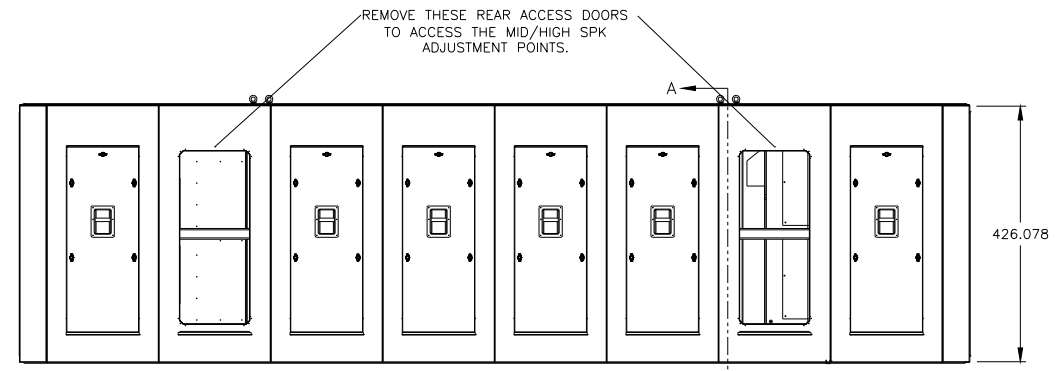

REAR VIEW
6 X SCALE

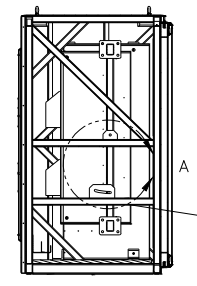

SECTION A-A

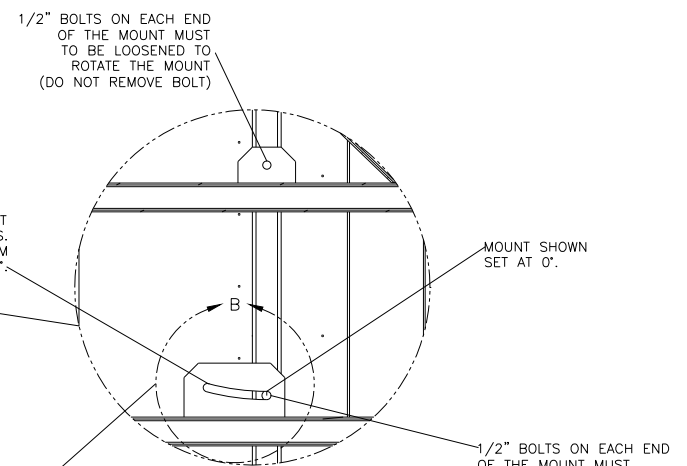

DETAIL A
SCALE 1:48

DIFFERENCE BETWEEN TOP OF STANDS AND BOTTOM OF CABINET (VALUE D) (D=A-C)	MID/HIGH SPEAKER AIMING CHART																			
25'	9	9	8	8	7	7	7	7	6	6	6	6	5	5	5	5	5	5	5	5
24'	9	8	8	7	7	7	7	6	6	6	6	5	5	5	5	5	5	5	4	4
23'	8	8	8	7	7	7	6	6	6	6	5	5	5	5	5	5	4	4	4	4
22'	8	8	7	7	7	6	6	6	6	5	5	5	5	5	5	4	4	4	4	4
21'	8	7	7	7	6	6	6	5	5	5	5	5	5	4	4	4	4	4	4	4
20'	7	7	7	6	6	6	6	5	5	5	5	5	4	4	4	4	4	4	4	4
19'	7	7	6	6	6	6	5	5	5	5	5	4	4	4	4	4	4	4	4	4
18'	7	6	6	6	5	5	5	5	5	4	4	4	4	4	4	4	4	4	4	4
17'	6	6	6	5	5	5	5	5	4	4	4	4	4	4	4	3	3	3	3	3
16'	6	6	5	5	5	5	4	4	4	4	4	4	4	3	3	3	3	3	3	3
15'	6	6	5	5	5	4	4	4	4	4	4	4	3	3	3	3	3	3	3	3
14'	6	5	5	5	4	4	4	4	4	4	3	3	3	3	3	3	3	3	3	3
13'	5	5	5	4	4	4	4	4	4	3	3	3	3	3	3	3	3	3	3	3
12'	5	5	4	4	4	4	4	4	3	3	3	3	3	3	3	3	3	3	3	3
11'	5	4	4	4	4	3	3	3	3	3	3	3	3	3	2	2	2	2	2	2
10'	4	4	4	4	4	3	3	3	3	3	3	3	3	2	2	2	2	2	2	2
9'	4	4	4	3	3	3	3	3	3	3	3	2	2	2	2	2	2	2	2	2
8'	4	3	3	3	3	3	3	3	2	2	2	2	2	2	2	2	2	2	2	2
7'	3	3	3	3	3	3	2	2	2	2	2	2	2	2	2	2	2	2	2	2
6'	3	3	3	2	2	2	2	2	2	2	2	2	2	2	2	2	2	2	2	2
5'	3	3	2	2	2	2	2	2	2	2	2	2	2	2	2	1	1	1	1	1
4'	2	2	2	2	2	2	2	2	2	2	1	1	1	1	1	1	1	1	1	1
3'	2	2	2	2	2	2	2	1	1	1	1	1	1	1	1	1	1	1	1	1
2'	2	2	2	2	1	1	1	1	1	1	1	1	1	1	1	1	1	1	1	1
1'	1	1	1	1	1	1	1	1	1	1	1	1	1	1	1	1	1	1	1	1
0'	1	1	1	1	1	1	1	1	1	1	1	1	1	1	1	1	1	1	1	1
-1'	1	1	1	1	1	1	1	1	1	1	0	0	0	0	0	0	0	0	0	0
-2'	0	0	0	0	0	0	0	0	0	0	0	0	0	0	0	0	0	0	0	0
-3'	0	0	0	0	0	0	0	0	0	0	0	0	0	0	0	0	0	0	0	0
-4' AND BELOW	0	0	0	0	0	0	0	0	0	0	0	0	0	0	0	0	0	0	0	0
	180	190	200	210	220	230	240	250	260	270	280	290	300	310	320	330	340	350		

DISTANCE TO CENTER OF STANDS (VALUE B)

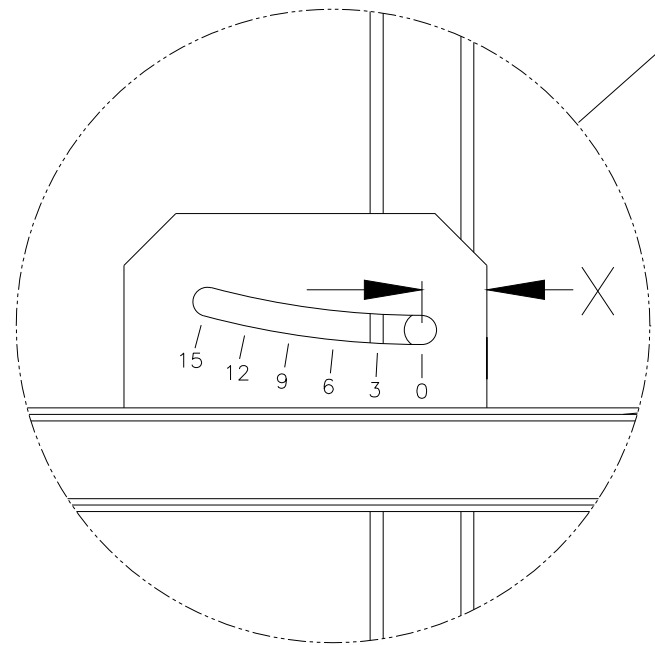

DETAIL B
SCALE 1:20

DEGREE NEEDED	X DIMENSION (IN.)
0	1.250
1	1.529
2	1.808
3	2.087
4	2.366
5	2.644
6	2.944
7	3.200
8	3.477
9	3.753

NOTE:
THE DEGREE TICK MARKS ARE NOT ON THE PART, IT IS SHOWN IN THE DETAIL FOR REFERENCE ONLY.
THE X DIMENSION IS ALWAYS MEASURED PERPENDICULAR TO THE EDGE OF THE PART.

NOTES:
-THE MID AND HIGH FREQUENCY SPEAKERS ARE ADJUSTABLE FROM 0° TO 15°. AN INCLINOMETER CAN BE USED TO DETERMINE THE ANGLE.
-A RATCHET STRAP CAN BE CONNECTED TO THE BOTTOM OF THE MID FREQUENCY MOUNT AND MIDDLE BACK VERTICAL MEMBER OF THE CABINET TO ASSIST IN ADJUSTING THE SPEAKER MOUNT.
-IF PROBLEMS WITH REFLECTION OCCUR DUE TO STRUCTURES LOCATED ON THE OPPOSITE END OF THE FIELD ADJUST THE SPEAKER MOUNT DOWN SO THE CENTER OF SPEAKERS POINT TOWARD THE END OF THE FIELD.
-THE SUBWOOFER REQUIRES NO ADJUSTMENT.

DAKTRONICS, INC.
BROOKINGS, SD 57006
DO NOT SCALE DRAWING

THE CONCEPTS EXPRESSED AND DETAILS SHOWN ON THIS DRAWING ARE CONFIDENTIAL AND PROPRIETARY. DO NOT REPRODUCE BY ANY MEANS WITHOUT THE EXPRESSED WRITTEN CONSENT OF DAKTRONICS, INC. COPYRIGHT 2010 DAKTRONICS, INC.

PROJ:SPORTSOUND SYSTEMS
TITLE:MID/HIGH SPEAKER AIMING CHART; 2000HD
DESIGN:KSCHNAB DRAWN:KSCHNAB DATE:9 JUL 10
SCALE:1/16" = 1'

SHEET	REV	JOB NO:	FUNC-TYPE-SIZE
	01	P1340	E-10-C

1023805

FIELD INSTALLED

COMPONENTS INTERNAL TO CONTROL ENCLOSURE

COMPONENTS EXTERNAL TO CONTROL ENCLOSURE

USE GREEN LABELS INSIDE CABINET AND CONTROL ENCLOSURE

W-2437, W-2438, W-2439 CONSIST OF ALL NECESSARY POWER, NETWORK, AND ANALOG CABLING FOR AMPLIFIERS; SEE DWG-01083215

ANALOG FROM FIBER CONVERSION BOX SEE DWG-984140

POWER CONNECTIONS SEE DWG-984140

FIBER FROM FIBER SPLICE BOX SEE DWG-984140

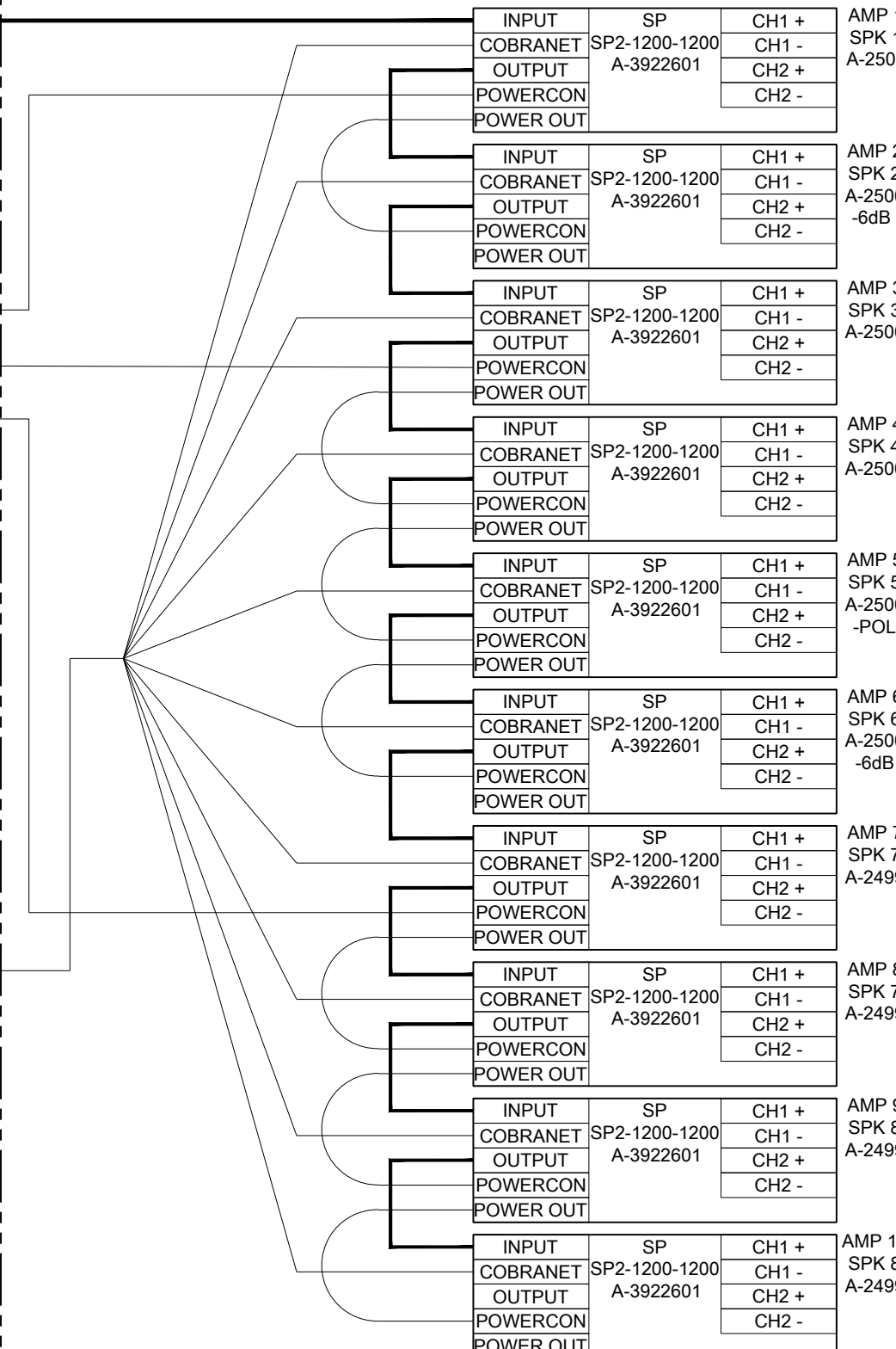
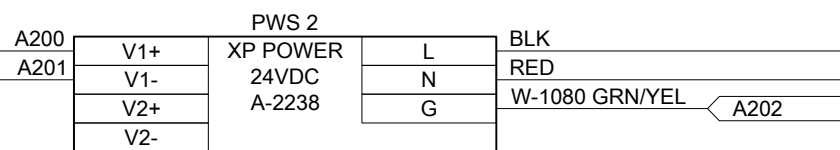
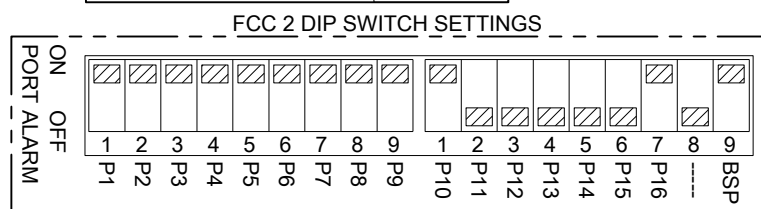
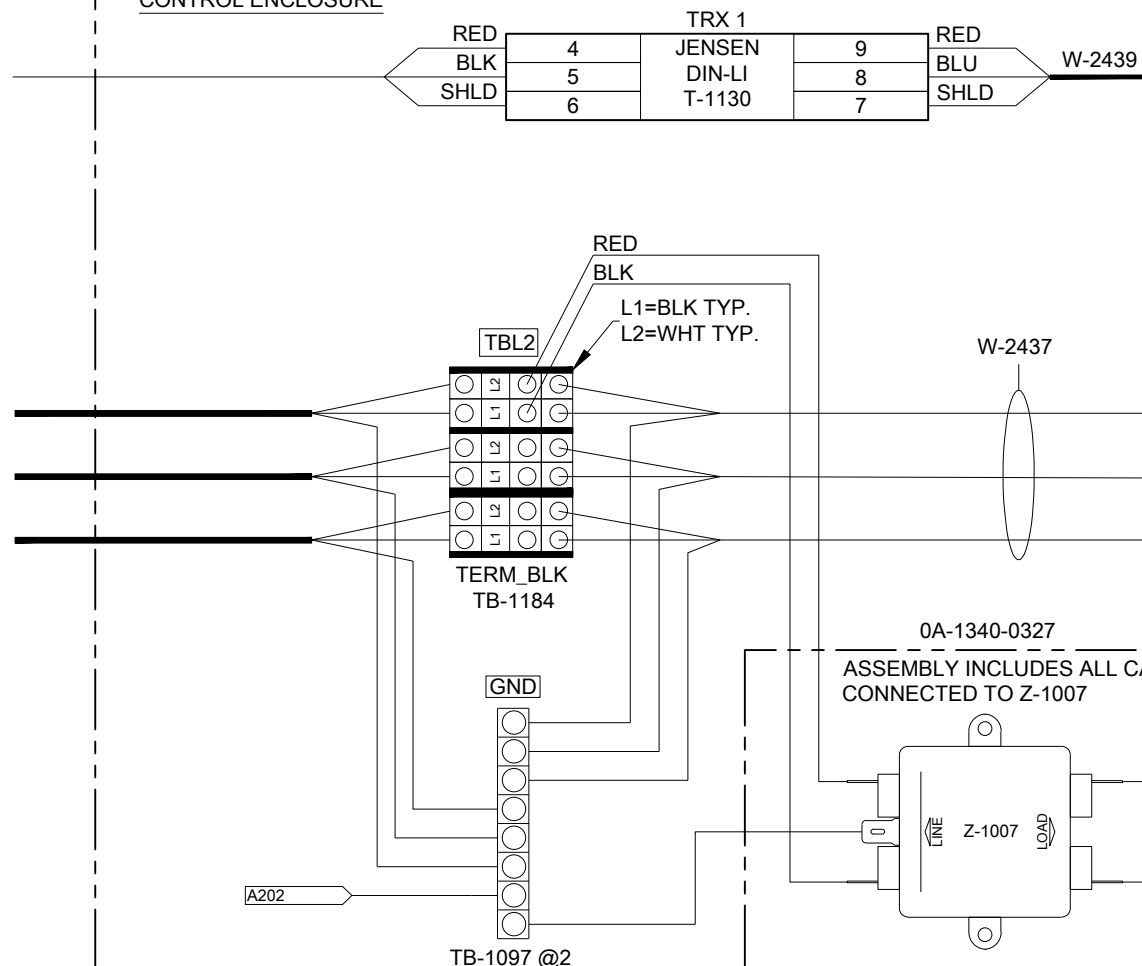

REF PACKET 0A-1340-2039 LABELS PACKET 0A-1340-2040 ADD-004556

REV 05	DATE: 30 JUL 18	2CH AMP A-2538 TO A-3922601	BY: CJB
REV 04	DATE: 4 FEB 15	UPDATED AMPLIFIER PART NUMBERS UPDATED DRAWING BLOCK STYLE	BY: CJB
REV 03	DATE: 09 OCT 13	FIXED WIRE COLOR LABEL ON PIN 8 OF TRX1	BY: DCS
REV 02	DATE: 26 OCT 12	FIXED WRONG PART NUMBERS	BY: CJB
REV 01	DATE: 31 MAY 12	ADDED 0A-1340-0327 UPDATED DRAWING STYLE	BY: CJB

DAKTRONICS

THE CONCEPTS EXPRESSED AND DETAILS SHOWN ON THIS DRAWING ARE CONFIDENTIAL AND PROPRIETARY. DO NOT REPRODUCE BY ANY MEANS WITHOUT THE EXPRESS WRITTEN CONSENT OF DAKTRONICS, INC. OR ITS WHOLLY OWNED SUBSIDIARIES. COPYRIGHT 2016 DAKTRONICS, INC. (USA)

THIRD ANGLE PROJECTION

PROJECT: SPORTSOUND SYSTEMS
 TITLE: SCHEMATIC; CONTROL ENCLOSURE/SOUND CABINET 2000HD
 DATE: 26 JAN 12 DIM UNITS: INCHES [MILLIMETERS] SHEET REV
 SCALE: NONE DO NOT SCALE DRAWING 05
 DESIGN: DSAND JOB NO. P1340 FUNC - TYPE - SIZE
 DRAWN: DSAND F-03-B 1082599

FIELD INSTALLED

W-1489, 6 CORE FIBER; TO FIBER SPLICE BOX/CONTROL ENCLOSURE

W-1615 TWISTED AUDIO CABLE; TO FIBER SPLICE BOX/CONTROL ENCLOSURE (ANALOG BACKUP)

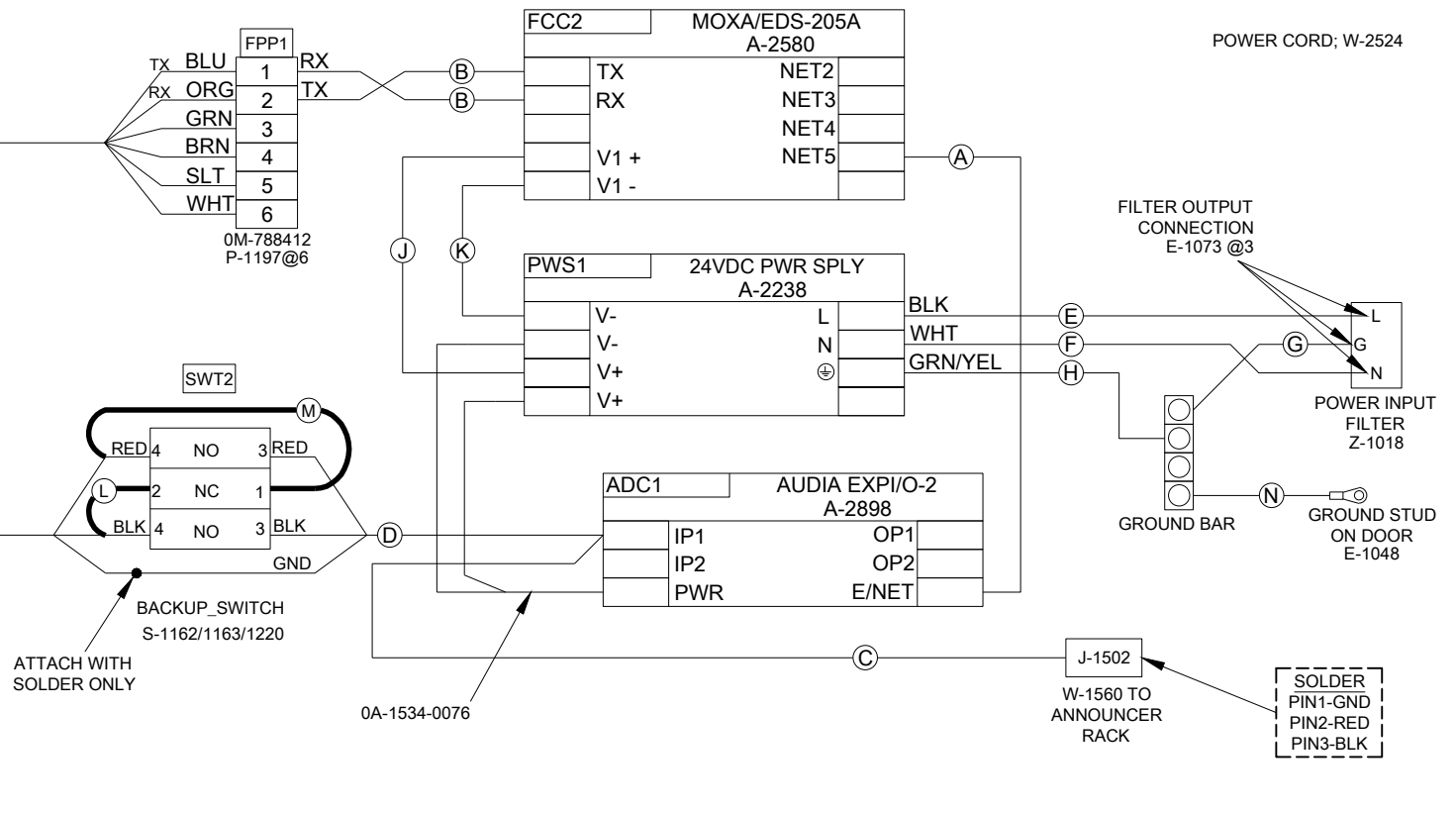

ATTACH WITH SOLDER ONLY

0A-1534-0076

WIRE C-N INCLUDED IN 0A-1534-0077

- (A) W-1542; 1' RJ45 CAT5E PATCH CABLE
- (B) W-1509; 1' ST-ST 50UM FIBER PATCH
- (C) W-1615; 22AWG AUDIO, 1 PAIR
- (D) W-1615; 22AWG AUDIO, 1 PAIR
- (E) W-1078; 14AWG BLACK
- (F) W-1079; 14AWG WHITE
- (G) W-1080; 14AWG GREEN/YELLOW
- (H) W-1080; 14AWG GREEN/YELLOW
- (J) W-1094; 18AWG RED
- (K) W-1092; 18AWG BLACK
- (L) W-1054; 22AWG BLACK; JUMPER WIRES
- (M) W-1054; 22AWG BLACK; JUMPER WIRES
- (N) W-1080; 14AWG GREEN/YELLOW

0A-1534-0060 F ASSY; ANALOG BACKUP FIBER BOX

REV	DATE:	UPDATED WIRING	BY:
02	24 JUN 13		CJB
01	2 NOV 12	ADDED TX AND RX TO FPP1	CJB

REV	DATE:	CN17330 REMOVED TERM BLOCK PART NUMBER CHANGED TO CURRENT DRAWING LAYOUT	BY:
03	07 APR 21		JSF

THE CONCEPTS EXPRESSED AND DETAILS SHOWN ON THIS DRAWING ARE CONFIDENTIAL AND PROPRIETARY. DO NOT REPRODUCE BY ANY MEANS WITHOUT THE EXPRESS WRITTEN CONSENT OF DAKTRONICS, INC. OR ITS WHOLLY OWNED SUBSIDIARIES. COPYRIGHT 2021 DAKTRONICS, INC. (USA)

PROJECT: SPORTSOUND SYSTEMS
 TITLE: AUDIO; SPORTSOUND, FIBER BOX SCHEMATIC

DATE:	DIM UNITS:	SHEET	REV
01 MAY 12	INCHES [MILLIMETERS]		03

SCALE: NTS DO NOT SCALE DRAWING

DESIGN:	JOB NO.	FUNC - TYPE - SIZE	REV
CBRANDT	P1340	R - 01 - A	03

DRAWN: CBRANDT

1095894

This page intentionally left blank.

B Supplementary Manuals

Manuals for all standard and optional components are shipped with the audio system.

- If any product manuals are missing, lost, or damaged, visit the manufacturer's website or perform a web search for the component model number.
- When viewing a digital copy of this manual from www.daktronics.com/manuals, click on the appropriate manufacturer link below to view a component's manual. If the link is broken, visit the manufacturer's website or perform a web search for the component model number.

Component	Model Number	Manufacturer	Manual(s)
Media Converter / Ethernet Switch	EDS-205A-M-ST	Moxa www.moxa.com	Installation Guide
Analog to Digital Converter	Audia EXPI/O-2	Biamp www.biamp.com	Operation Manual

This page intentionally left blank.

C Daktronics Warranty & Limitation of Liability

This section includes the Daktronics Warranty & Limitation of Liability statement (SL-02374).

This page intentionally left blank.

DAKTRONICS WARRANTY & LIMITATION OF LIABILITY

This Warranty and Limitation of Liability (the "Warranty") sets forth the warranty provided by Daktronics with respect to the Equipment. By accepting delivery of the Equipment, Purchaser and End User agree to be bound by and accept these terms and conditions. Unless otherwise defined herein, all terms within the Warranty shall have the same meaning and definition as provided elsewhere in the Agreement.

DAKTRONICS WILL ONLY BE OBLIGATED TO HONOR THE WARRANTY SET FORTH IN THESE TERMS AND CONDITIONS UPON RECEIPT OF FULL PAYMENT FOR THE EQUIPMENT

1. Warranty Coverage.

- A. Daktronics warrants to the original end user (the "End User", which may also be the Purchaser) that the Equipment will be free from Defects (as defined below) in materials and workmanship for a period of one (1) year (the "Warranty Period"). The Warranty Period shall commence on the earlier of: (i) four weeks from the date that the Equipment leaves Daktronics' facility; or (ii) Substantial Completion as defined herein. The Warranty Period shall expire on the first anniversary of the commencement date.

"Substantial Completion" means the operational availability of the Equipment to the End User in accordance with the Equipment's specifications, without regard to punch-list items, or other non-substantial items which do not affect the operation of the Equipment

- B. Daktronics' obligation under this Warranty is limited to, at Daktronics' option, replacing or repairing, any Equipment or part thereof that is found by Daktronics not to conform to the Equipment's specifications. Unless otherwise directed by Daktronics, any defective part or component shall be returned to Daktronics for repair or replacement. This Warranty does not include on-site labor charges to remove or install these components. Daktronics may, at its option, provide on-site warranty service. Daktronics shall have a reasonable period of time to make such replacements or repairs and all labor associated therewith shall be performed during regular working hours. Regular working hours are Monday through Friday between 8:00 a.m. and 5:00 p.m. at the location where labor is performed, excluding any holidays observed by Daktronics.
- C. Daktronics shall pay ground transportation charges for the return of any defective component of the Equipment. All such items shall be shipped by End User DDP Daktronics designated facility per Incoterms® 2020. If returned Equipment is repaired or replaced under the terms of this Warranty, Daktronics will prepay ground transportation charges back to End User and shall ship such items DDP End User's designated facility per Incoterms® 2020; otherwise, End User shall pay transportation charges to return the Equipment back to the End User and such Equipment shall be shipped Ex Works Daktronics designated facility per Incoterms® 2020. All returns must be pre-approved by Daktronics before shipment. Daktronics shall not be obligated to pay freight for any unapproved return. End User shall pay any upgraded or expedited transportation charges
- D. Any replacement parts or Equipment will be new or serviceably used, comparable in function and performance to the original part or Equipment and warranted for the remainder of the Warranty Period. Purchasing additional parts or Equipment from the Seller does not extend the Warranty Period.
- E. Defects shall be defined as follows. With regard to the Equipment (excepting LEDs), a "Defect" shall refer to a material variance from the design specifications that prohibit the Equipment from operating for its intended use. With respect to LEDs, "Defects" are defined as LED pixels that cease to emit light. Unless otherwise expressly provided, this Warranty does not impose any duty or liability upon Daktronics for partial LED pixel degradation. Notwithstanding the foregoing, in no event does this Warranty include LED pixel degradation caused by UV light. This Warranty does not provide for the replacement or installation of communication methods including but not limited to, wire, fiber optic cable, conduit, trenching, or for the purpose of overcoming local site interference radio equipment substitutions.

EXCEPT AS OTHERWISE EXPRESSLY SET FORTH IN THIS WARRANTY, TO THE MAXIMUM EXTENT PERMITTED BY APPLICABLE LAW, DAKTRONICS DISCLAIMS ANY AND ALL OTHER PROMISES, REPRESENTATIONS AND WARRANTIES APPLICABLE TO THE EQUIPMENT AND REPLACES ALL OTHER WARRANTIES OR CONDITIONS, EXPRESS OR IMPLIED, INCLUDING, BUT NOT LIMITED TO, ANY IMPLIED WARRANTIES OR CONDITIONS OF MERCHANTABILITY, FITNESS FOR A PARTICULAR PURPOSE, OR ACCURACY OR QUALITY OF DATA. OTHER ORAL OR WRITTEN INFORMATION OR ADVICE GIVEN BY DAKTRONICS, ITS AGENTS OR EMPLOYEES, SHALL NOT CREATE A WARRANTY OR IN ANY WAY INCREASE THE SCOPE OF THIS LIMITED WARRANTY.

THIS LIMITED WARRANTY IS NOT TRANSFERABLE.

2. Exclusion from Warranty Coverage

This Warranty does not impose any duty or liability upon Daktronics for any:

- A. damage occurring at any time, during shipment of Equipment unless otherwise provided for in the Agreement. When returning Equipment to Daktronics for repair or replacement, End User assumes all risk of loss or damage, agrees to use any shipping containers that might be provided by Daktronics, and to ship the Equipment in the manner prescribed by Daktronics;
- B. damage caused by: (i) the improper handling, installation, adjustment, use, repair, or service of the Equipment, or (ii) any physical damage which includes, but is not limited to, missing, broken, or cracked components resulting from non-electrical causes;

DAKTRONICS WARRANTY & LIMITATION OF LIABILITY

altered, scratched, or fractured electronic traces; missing or gauged solder pads; cuts or clipped wires; crushed, cracked, punctured, or bent circuit boards; or tampering with any electronic connections, provided that such damage is not caused by personnel of Daktronics or its authorized repair agents;

- C. damage caused by the failure to provide a continuously suitable environment, including, but not limited to: (i) neglect or misuse; (ii) improper power including, without limitation, a failure or sudden surge of electrical power; (iii) improper air conditioning, humidity control, or other environmental conditions outside of the Equipment's technical specifications such as extreme temperatures, corrosives and metallic pollutants; or (iv) any other cause other than ordinary use;
- D. damage caused by fire, flood, earthquake, water, wind, lightning or other natural disaster, strike, inability to obtain materials or utilities, war, terrorism, civil disturbance, or any other cause beyond Daktronics' reasonable control;
- E. failure to adjust, repair or replace any item of Equipment if it would be impractical for Daktronics personnel to do so because of connection of the Equipment by mechanical or electrical means to another device not supplied by Daktronics, or the existence of general environmental conditions at the site that pose a danger to Daktronics personnel;
- F. statements made about the product by any salesperson, dealer, distributor or agent, unless such statements are in a written document signed by an officer of Daktronics. Such statements as are not included in a signed writing do not constitute warranties, shall not be relied upon by End User and are not part of the contract of sale;
- G. damage arising from the use of Daktronics products in any application other than the commercial and industrial applications for which they are intended, unless, upon request, such use is specifically approved in writing by Daktronics;
- H. replenishment of spare parts. In the event the Equipment was purchased with a spare parts package, the parties acknowledge and agree that the spare parts package is designed to exhaust over the life of the Equipment, and as such, the replenishment of the spare parts package is not included in the scope of this Warranty;
- I. security or functionality of the End User's network or systems, or anti-virus software updates;
- J. performance of preventive maintenance;
- K. third-party systems and other ancillary equipment, including without limitation front-end video control systems, audio systems, video processors and players, HVAC equipment, batteries and LCD screens;
- L. incorporation of accessories, attachments, software or other devices not furnished by Daktronics; or
- M. paint or refinishing the Equipment or furnishing material for this purpose.

3. Limitation of Liability

- A. Daktronics shall be under no obligation to furnish continued service under this Warranty if alterations are made to the Equipment without the prior written approval of Daktronics.
- B. It is specifically agreed that the price of the Equipment is based upon the following limitation of liability. In no event shall Daktronics (including its subsidiaries, affiliates, officers, directors, employees, or agents) be liable for any claims asserting or based on (a) loss of use of the facility or equipment; lost business, revenues, or profits; loss of goodwill; failure or increased cost of operations; loss, damage or corruption of data; loss resulting from system or service failure, malfunction, incompatibility, or breaches in system security; or (b) any special, consequential, incidental or exemplary damages arising out of or in any way connected with the Equipment or otherwise, including but not limited to damages for lost profits, cost of substitute or replacement equipment, down time, injury to property or any damages or sums paid to third parties, even if Daktronics has been advised of the possibility of such damages. The foregoing limitation of liability shall apply whether any claim is based upon principles of contract, tort or statutory duty, principles of indemnity or contribution, or otherwise
- C. In no event shall Daktronics be liable for loss, damage, or injury of any kind or nature arising out of or in connection with this Warranty in excess of the Purchase Price of the Equipment. The End User's remedy in any dispute under this Warranty shall be ultimately limited to the Purchase Price of the Equipment to the extent the Purchase Price has been paid.

4. Assignment of Rights

- A. The Warranty contained herein extends only to the End User (which may be the Purchaser) of the Equipment and no attempt to extend the Warranty to any subsequent user-transferee of the Equipment shall be valid or enforceable without the express written consent of Daktronics.

5. Governing Law; Election of Remedies

- A. The rights and obligations of the parties under this Warranty shall not be governed by the provisions of the United Nations Convention on Contracts for the International Sales of Goods of 1980. The parties consent to the application of the laws of the State of South Dakota to govern, interpret, and enforce each of the parties' rights, duties, and obligations arising from, or relating in any manner to, the subject matter of this Warranty, without regard to conflict of law principles.
- B. Any dispute, controversy or claim arising from or related to this Warranty, the parties shall first attempt to settle through negotiations. In the event that no resolution is reached, then such dispute, controversy, or claim shall be resolved by final and binding arbitration under the Rules of Arbitration of the International Chamber of Commerce. The language of the arbitration



DAKTRONICS WARRANTY & LIMITATION OF LIABILITY

shall be English. The place of the arbitration shall be Sioux Falls, SD. A single arbitrator selected by the parties shall preside over the proceeding. If a single arbitrator cannot be agreed upon by the parties, each party shall select an arbitrator, and those arbitrators shall confer and agree on the appointed arbitrator to adjudicate the arbitration. The arbitrator shall have the power to grant any provisional or final remedy or relief that it deems appropriate, including conservatory measures and an award of attorneys' fees. The arbitrator shall make its decisions in accordance with applicable law. By agreeing to arbitration, the Parties do not intend to deprive any court of its jurisdiction to issue a pre-arbitral injunction, pre-arbitral attachment, or other order in aid of arbitration proceedings and the enforcement of any award. Without prejudice to such provisional remedies as may be available under the jurisdiction of a court, the arbitrator shall have full authority to grant provisional remedies and to direct the Parties to request that any court modify or vacate any temporary or preliminary relief issued by such court, and to award damages for the failure of any Party to respect the arbitrator's orders to that effect.

6. Availability of Extended Service Agreement

- A. For End User's protection, in addition to that afforded by the warranties set forth herein, End User may purchase extended warranty services to cover the Equipment. The Extended Service Agreement, available from Daktronics, provides for electronic parts repair and/or on-site labor for an extended period from the date of expiration of this warranty. Alternatively, an Extended Service Agreement may be purchased in conjunction with this Warranty for extended additional services. For further information, contact Daktronics Customer Service at 1-800-DAKTRONics (1-800-325-8766).

Additional Terms applicable to sales outside of the United States

The following additional terms apply **only** where the installation site of the Equipment is located outside of the United States of America.

1. In the event that the installation site of the Equipment is in a country other than the U.S.A., then, notwithstanding Section 5 of the Warranty, where the selling entity is the entity listed in Column 1, then the governing law of this Warranty is the law of the jurisdiction listed in the corresponding row in Column 2 without regard to its conflict of law principles. Furthermore, if the selling entity is an entity listed in Column 1, then the place of arbitration is listed in the corresponding row in Column 3.

Column 1 (Selling Entity)	Column 2 (Governing Law)	Column 3 (Location of Arbitration)
Daktronics, Inc.	The state of Illinois	Chicago, IL, U.S.A.
Daktronics Canada, Inc.	The Province of Ontario, Canada	Toronto, Ontario, Canada
Daktronics UK Ltd.	England and Wales	Bristol, UK
Daktronics GmbH	The Federal Republic of Germany	Wiesbaden, Germany
Daktronics Hong Kong Limited	Hong Kong, Special Administrative Region of the P.R.C.	Hong Kong SAR
Daktronics Shanghai Co., Ltd.	The Peoples Republic of China	Shanghai, P.R.C.
Daktronics France, SARL	France	Paris, France
Daktronics Japan, Inc.	Japan	Tokyo, Japan
Daktronics International Limited	Macau, Special Administrative Region of the P.R.C.	Macau SAR
Daktronics Australia Pad Ltd	Australia	Sydney, Australia
Daktronics Singapore Pte. Ltd	Singapore	Singapore
Daktronics Brazil LTDA	Brazil	São Paulo, Brazil
Daktronics Spain S.L.U.	Spain	Madrid, Spain
Daktronics Belgium N. V	Belgium	Kruikeke, Belgium
Daktronics Ireland Co. Ltd.	Ireland	Dublin, Ireland

This page intentionally left blank.