

**ST-31XY SERIES
SCORERS TABLES**

DISPLAY MANUAL

P2307

DD4924982
Rev 04
14 June 2023



Copyright © 2023

All rights reserved. While every precaution has been taken in the preparation of this manual, the publisher assumes no responsibility for errors or omissions. No part of this book covered by the copyrights hereon may be reproduced or copied in any form or by any means—graphic, electronic, or mechanical, including photocopying, taping, or information storage and retrieval systems—without written permission of the publisher.

Daktronics trademarks are property of Daktronics, Inc. All other trademarks are property of their respective companies.

Table of Contents

1	Introduction	1
	Important Safeguards.....	1
	Resources.....	1
	Numbering Conventions.....	2
	Module Number	2
	Part Number	2
	Model Number	2
	Light Strip Controllers.....	2
2	Uncrating	3
	Attach Caster Bases.....	3
	Remove Table from Shipping Brackets.....	6
3	Mechanical Installation	8
	Caster Base Tool.....	8
	Table Setup – Transport to Stationary Mode.....	9
	Table Teardown – Stationary to Transport Mode.....	14
	Adjust Tabletop Level.....	16
	Multiple Table Connection.....	17
	Attach End Pads.....	18
	Attach Top Pads.....	19
	Adjust Display Face Angle.....	20
4	Electrical Installation	22
	Warnings and Disclaimers.....	22
	Power Summary.....	22
	Signal Summary.....	22
	Fiber-Optic Connectors.....	23
	Control Cable.....	23
	Display Power.....	24
	Grounding	24
	Convenience & USB Outlets	24
	Display Wiring.....	24
	Power Cables	24
	Signal Cables	25
	Interconnect Cables with Embedded Controller	25
	Fiber Connections.....	25
	Network Connections.....	25
	Interconnect Cables with External Controller	25
	Fiber Connections.....	25
	Network Connections.....	25
	End-of-Period and Clock Stop Light Strip Kits.....	26
	Possession Indicator.....	27
	Display Power Up.....	27

Table of Contents

5	Maintenance & Troubleshooting	28
	Recommended Tools.....	28
	Front Access.....	28
	Hub Board/Receiver Card Replacement	30
	Power Supply Replacement	31
	Rear Access	31
	Power Supply Replacement	31
	Components	32
	Power Supply	32
	ProLink Router (PLR)	32
	Digital Media Player (DMP)	32
	Display Interface (DI)	32
	Light Strip Driver.....	33
	Replacing a Driver	34
	Setting the Driver Address	34
	Tabletop Possession Indicators.....	35
	Troubleshooting	35
	Display	35
	Light Strips	36
6	Daktronics Exchange and Repair & Return Programs	37
	Exchange Program	37
	Repair & Return Program.....	38
	Daktronics Warranty & Limitation of Liability	38
	Glossary	39
A	Reference Drawings	41
B	Daktronics Warranty and Limitation of Liability	65

1 Introduction

This manual explains the installation, maintenance, and troubleshooting of a Daktronics scorers table system. For additional information regarding the safety, installation, operation, or service of this system, refer to the telephone numbers listed in **Section 6: Daktronics Exchange and Repair & Return Programs (p.37)**. This manual is not specific to a particular installation. Contract-specific information takes precedence over any other general information found in this manual.

Important Safeguards

- **Read and understand all instructions before beginning the installation process.**
- **Disconnect the display power when not in use or when servicing.**
- **Disconnect the display power before servicing power supplies to avoid electrical shock. Power supplies run on high voltage and may cause physical injury if touched while powered.**
- **Do not modify the structure or attach any panels or coverings to the display without the express written consent of Daktronics.**
- **Do not disassemble control equipment or electronic controls of the display; failure to follow this safeguard will make the warranty null and void.**
- **Do not drop the control equipment or allow it to get wet.**

Resources

Figure 1 illustrates a Daktronics drawing label. This manual refers to drawings by listing the last set of digits. In the example, the drawing would be referred to as **DWG-1007804**. All references to drawing numbers, appendices, figures, or other manuals are presented in bold typeface. Any drawings referenced in a particular section are listed at the beginning of it as shown below:

		DAKTRONICS, INC. BROOKINGS, SD 57006	THE CONCEPTS EXPRESSED AND DETAILS SHOWN ON THIS DRAWING ARE CONFIDENTIAL AND PROPRIETARY. DO NOT REPRODUCE BY ANY MEANS WITHOUT THE EXPRESSED WRITTEN CONSENT OF DAKTRONICS, INC. COPYRIGHT 2010 DAKTRONICS, INC.
DO NOT SCALE DRAWING			
PROJ: DAKTRONICS			
TITLE: SYSTEM RISER DIAGRAM			
DESIGN:		DRAWN: APAGE	DATE: 11 MAY 10
SCALE: NONE			
SHEET	REV	JOB NO:	FUNC-TYPE-SIZE
200	02	C17581	F-01-D

Drawing Number

Figure 1: Drawing Label

Reference Drawing:

System Riser Diagram **DWG-1007804**

Listed below are drawing types commonly used by Daktronics, along with the information each is likely to provide. All drawings referenced in this manual are found in **Appendix A**.

- **Schematic Drawings:** describe internal power and signal wiring as well as interconnections between display sections
- **Shop Drawings:** describe mounting methods to structural elements, access method (front or rear), and power and signal entrance points
- **System Riser Diagrams:** describe power/signal connections between components and the control location; may also include control room layout and schematic
- **Final Assembly Drawings:** describe internal display component locations and detailed product appearance with part numbers and quantities

Daktronics identifies manuals by the DD or ED number located on the cover page.

Ensure all applicable materials have been gathered before beginning the installation. Contact a Daktronics sales coordinator or project manager.

For additional support resources, including instructional videos and knowledge base articles, scan the QR code at right.



Numbering Conventions

Module Number

Figure 2 illustrates how Daktronics numbers modules on a digital display, and **Figure 3** explains the module labeling method in more detail.



Figure 2: Module Numbering

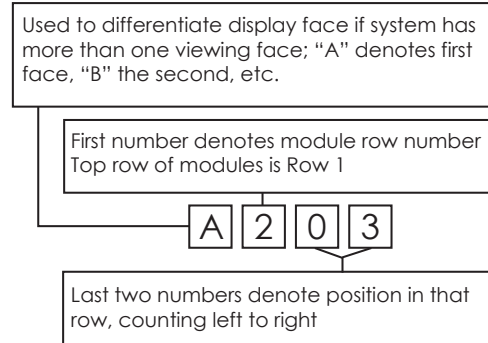

Figure 3: Module Numbering Breakdown

Part Number

Part numbers will appear on certain drawings and illustrations. Most display components have a white label that lists the part number as shown in **Figure 4**. Use this label to order a replacement. Refer to **Section 6: Daktronics Exchange and Repair & Return Programs (p.37)** if replacing or repairing any display component.

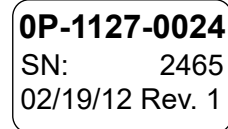

Figure 4: Part Label

Part Type	Part Example	Part Number
Assembly	Display interface board and the mounting plate or bracket	0A-XXXX-XXXX
Individual display interface board	ProLink Router (PLR)	0P-XXXX-XXXX
Wire or cable	Power cable	W-XXXX

Model Number

Each display system has a model number that explains the display specifications.

Please have the assembly number, model number, and the date manufactured on hand when calling Daktronics customer service to ensure the request is serviced as quickly as possible. Knowing the facility name and/or job number will also be helpful.

ST-31XY-3.9/5.9MN-HxW		
ST	=	Product series
31XY	=	Product generation
3.9/5.9MN	=	Pixel pitch & layout
H	=	Display height (pixels)
W	=	Display width (pixels)

Light Strip Controllers

Daktronics scorers tables equipped with optional End-of-Period (EOP) and/or Clock Stop light strips require an All Sport® 5000 console to control them. For operating instructions, refer to the **All Sport 5000 Series Control Console Operation Manual (ED-11976)**, available online at www.daktronics.com/manuals. Refer to **End-of-Period and Clock Stop Light Strip Kits (p.26)** for more information about installing optional light strips.

2 Uncrating

Use a pry bar to carefully remove the side panels of the crate, and then remove the top of the crate. Each crate may contain one, two, or three tables.

Attach Caster Bases

1. Locate a caster base assembly under the table. Each table has two caster base assemblies regardless of width.
2. Use a utility knife to cut through the plastic wrap around the caster base assembly. Refer to **Figure 5**.

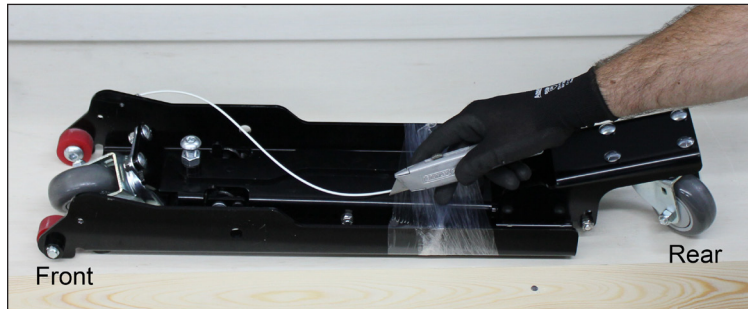

Figure 5: Remove Plastic Wrap from Caster Base

3. Lift the Caster Base Tool (attached by lanyard) off of the caster base assembly and set aside. Refer to **Figure 6**.



Figure 6: Remove Caster Base Tool

4. Holding the caster base steady with one hand, slip a couple fingers of your other hand under the caster base pivot arm and lift up until it is fully extended. Refer to **Figure 7**.

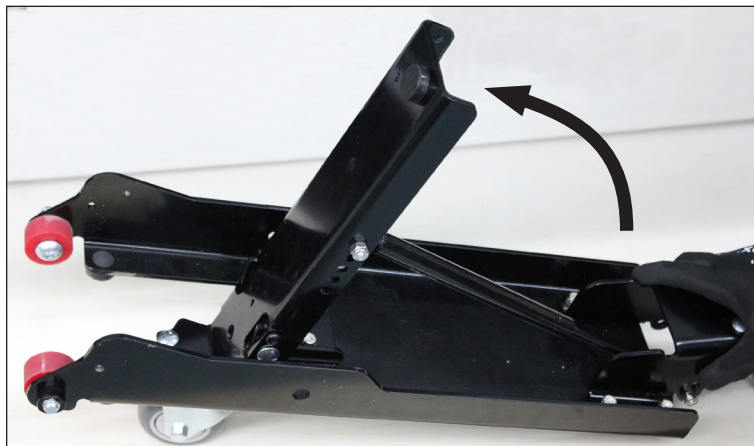

Figure 7: Lift Pivot Arm

5. Use a T30 Torx bit to remove the two 1/4" Torx screws toward the front of the caster base. Refer to **Figure 8**. Be careful to not lose these screws; they will be reinstalled after the caster base is attached to the table.



Figure 8: Remove Torx Screws

6. Use the provided 5/16" Allen wrench to remove the bolts securing the two red wheels. Refer to **Figure 9**. Set these bolts and wheels aside; they will be reinstalled after the caster base is attached to the table.



Figure 9: Remove Front Red Wheels

7. Locate a caster base vert underneath the table, and line up the caster base with the holes. Refer to **Figure 10**.

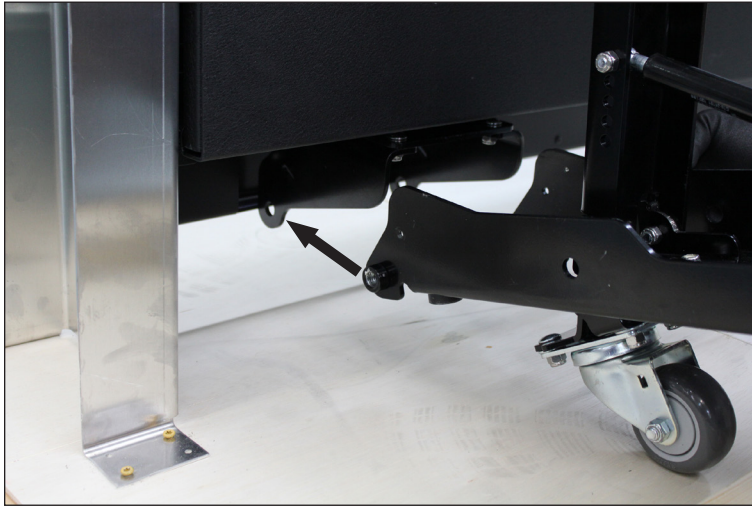

Figure 10: Line up Caster Base Assembly with Caster Base Vert

8. Use the 5/16" Allen wrench to reinstall the red wheels from *inside* the caster base to attach it to the bottom of the table. Refer to **Figure 11**. Do not overtighten the bolts; the wheels should be able to spin freely.

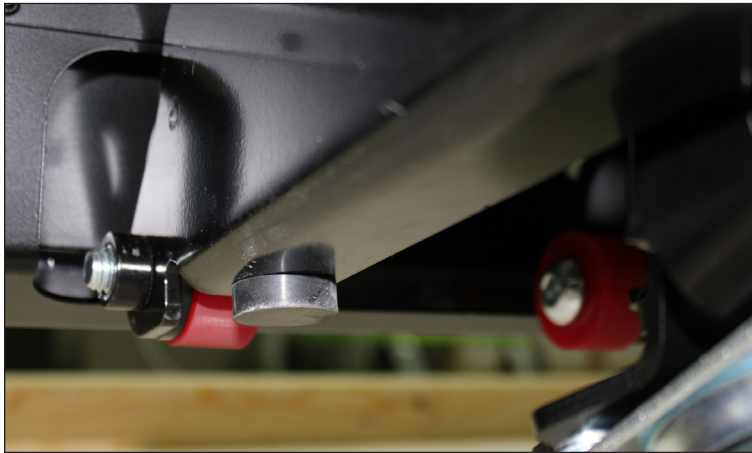

Figure 11: Reinstall Front Red Wheels Inside Caster Base

9. Use a T30 Torx bit to reinstall both 1/4" Torx screws. Refer to **Figure 12**. These bolts act as stops to prevent the front face of the table from tilting forward more than 90°.

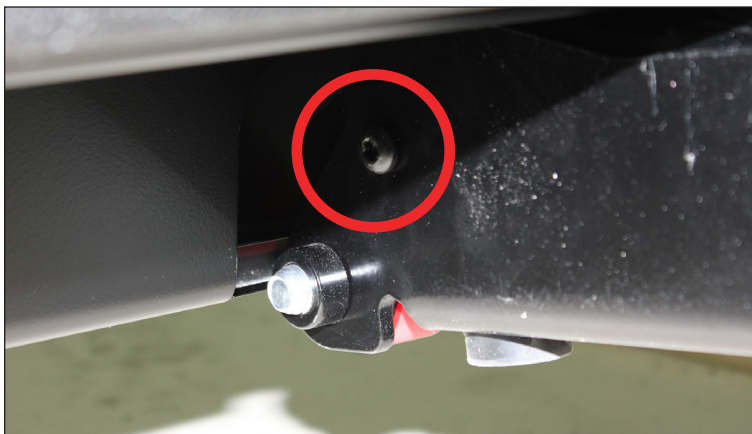

Figure 12: Reinstall Torx Screws

10. Place the Caster Base Tool diagonally from center to bottom-right in the caster base. Refer to **Figure 13**. Store the tool in this location whenever the table is not in use.



Figure 13: Caster Base Tool in Storage Position
(Tool Highlighted Orange for Clarity)

11. Repeat **Steps 1–10** for the other caster base.

Remove Table from Shipping Brackets

1. Once both caster bases are fully installed, stand on one side near the shipping bracket and use a utility knife to cut through the plastic wrap. Refer to **Figure 14**. Cutting the plastic wrap anywhere else has the potential to damage the table.



Figure 14: Remove Wrap from Table

2. Use a 3/4" socket to loosen the four shipping bracket bolts. Refer to **Figure 15**.



Figure 15: Loosen Four Shipping Brackets

3. With one person standing on either end of the table to support it, use a 3/4" socket to remove both top shipping bracket bolts.
4. Tilt the table backward so that the caster base/wheels are resting on the crate. Refer to **Figure 16**.

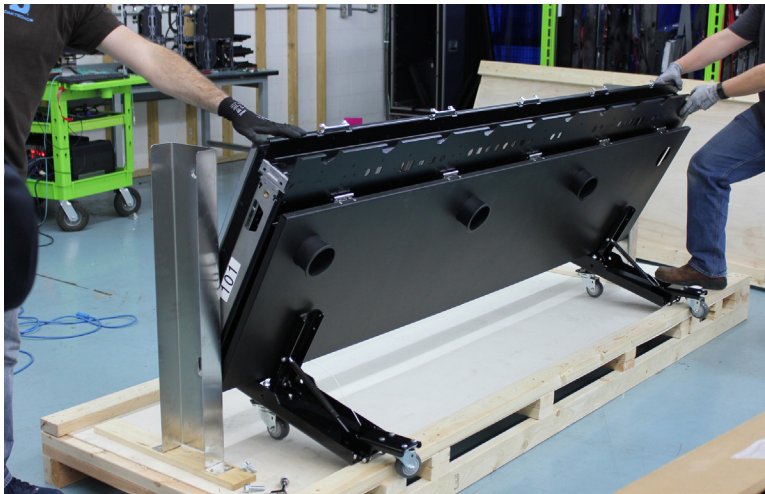

Figure 16: Tilt Table Backward

5. Use a 3/4" socket to remove the bottom two shipping bracket bolts.
6. Carefully roll the table back off the crate, lifting the front caster base wheels as needed to clear the bottom horizontal brace, and rest the table on the floor.

3 Mechanical Installation

All decisions regarding display setup must conform to the specifications and guidelines in this section. Read both the mechanical and electrical installation sections before beginning any installation procedures.

Reference Drawings:

Shop; ST-3130, 126X504-5.9/192X768-3.9	DWG-4874201
Shop; ST-3130, 126X1008-5.9/192X1536-3.9	DWG-4879040
Shop; ST-3130, 126X1512-5.9/192X2304-3.9	DWG-4879041
Shop; ST-3130, 126X2016-5.9/192X3072-3.9	DWG-4879042

The tabletop should be upright only during games and events, and it should be in the dropped position when moving and storing the table. The tabletop capacity is rated at a maximum of 150 lb (68 kg).

Depending on the length of the power cords, the table(s) should be within 25' (7.6 m), 50' (15.2 m), or 75' (22.9 m) of a power outlet.

Caster Base Tool

Each table comes with one Caster Base Tool (Daktronics part # HS-4939703) located in the bottom channel of each caster base (two per table). Refer to **Figure 17**. These tools serve a dual purpose of helping to pull down the caster base pivot arms when setting up the table as well as setting the display face to the desired angle. The tools are attached to the caster base by a steel lanyard to prevent being lost or stolen.

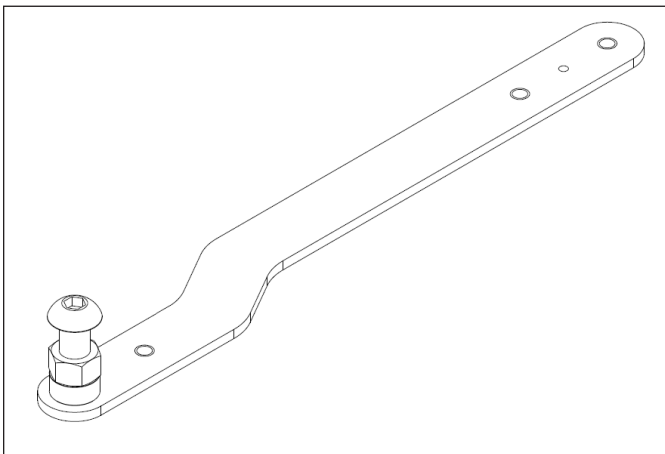

Figure 17: Caster Base Tool

Note: The bolt head on the end of the Caster Base Tool sets the display face angle to 5° and in most cases will not need to be adjusted. However, if adjustment is needed, refer to **Adjust Display Face Angle (p.20)**.

Table Setup – Transport to Stationary Mode

1. With the table in its desired location, move to the rear and roll it backwards slightly so the front caster on each caster base is rotated fully forward. Note the orientation of the front caster as shown in **Figure 18**.

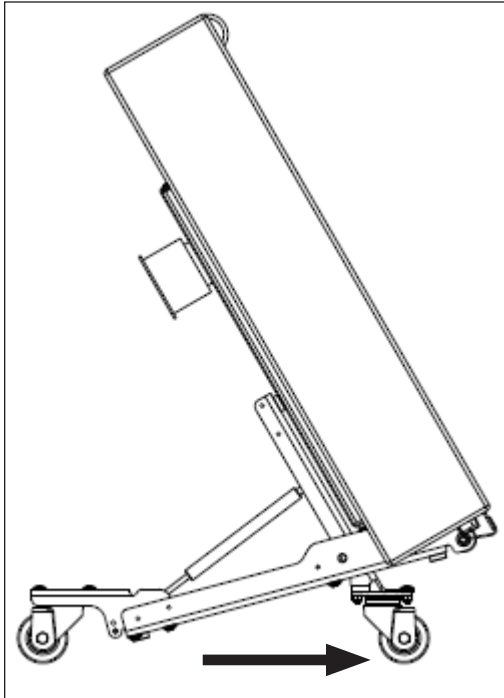

Figure 18: Transport Mode - Side View

2. Locate the Caster Base Tool in the bottom channel of the right caster base. Line up and insert the studs on the Caster Base Tool with the mating holes in the side of the pivot arm on the caster base. Refer to **Figure 19**.

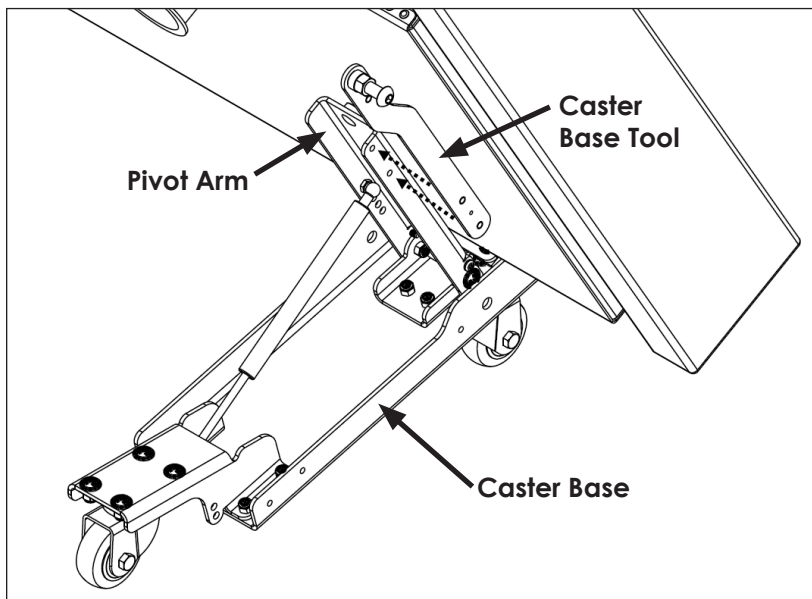

Figure 19: Insert Caster Base Tool into Pivot Arm

3. Use the offset end of the Caster Base Tool as leverage to pull down the pivot arm and lower the right side of the table to the floor. Refer to **Figure 20**.

Note: Do not push on the top of the table during this process as that may cause the front caster to rotate and make the table difficult to move/reposition as described in **Step 5**.

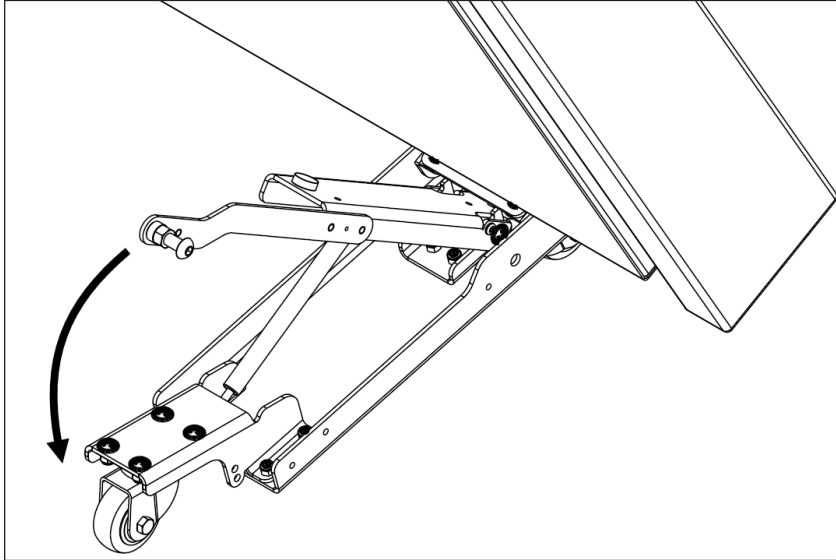

Figure 20: Pull Down Pivot Arm

4. Move to the left side caster base and repeat **Steps 2-3**. The table should now be resting on the floor. Refer to **Figure 21**.

Note: The rear casters may need to be rotated fully rearward to ensure both caster bases are firmly resting on the floor.

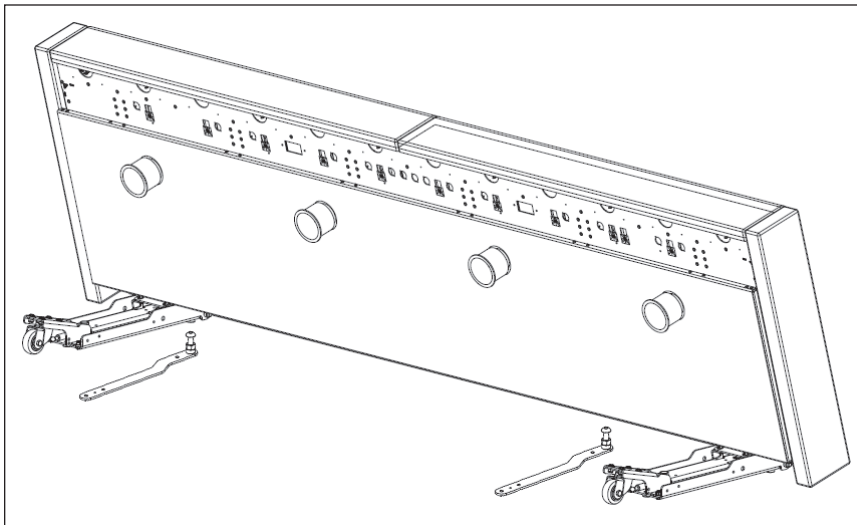

Figure 21: Both Caster Bases Resting on Floor

5. After both pivot arms are lowered, adjust the position of the table as necessary. Refer to **Figure 22**. Lift up slightly on the rear of one caster base so the table is supported by the rollers on the front of the caster base, and push/pull the table forward/backward. Repeat for the other caster base on the other end of the table as needed.

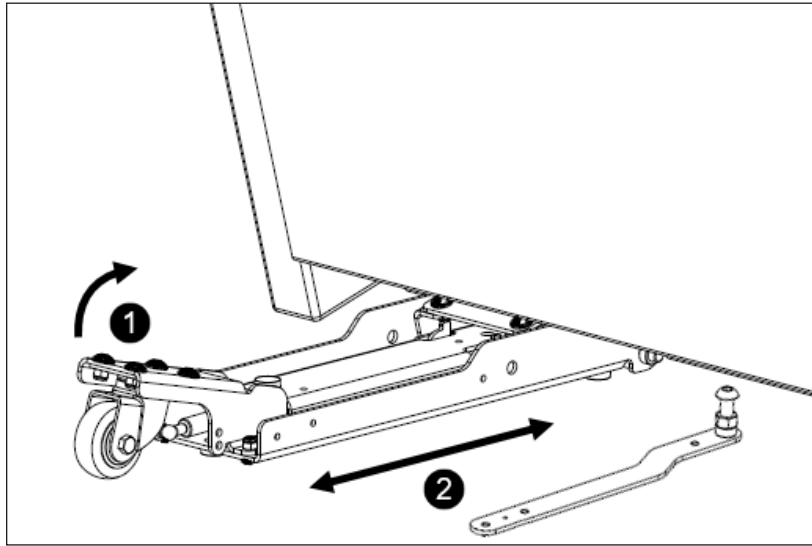

Figure 22: Fine-Tune Table Position

6. Carefully tilt the display face forward enough to insert the studs of the Caster Base Tool with the mating holes on the top of each caster base pivot arm. Refer to **Figure 23**.

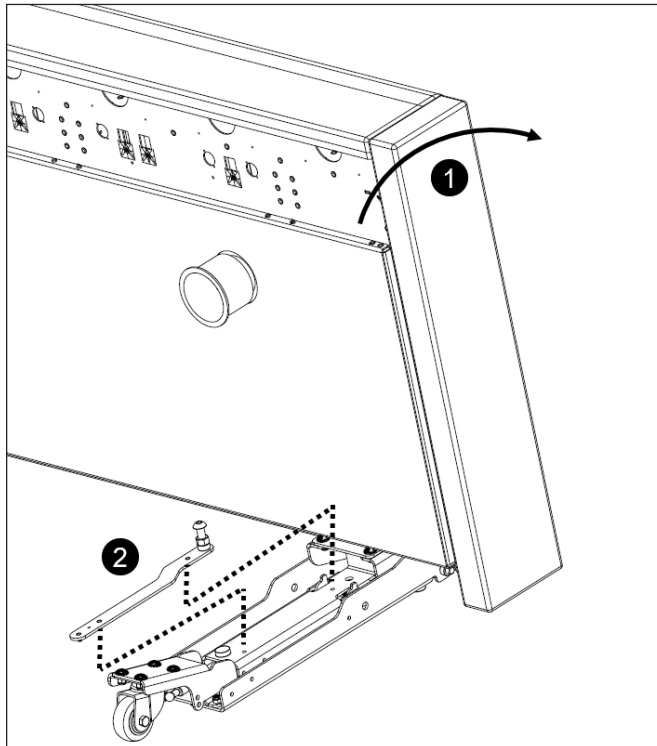

Figure 23: Caster Base Tool Location for Setting Face Angle

Note: The bolt head on the end of the Caster Base Tool sets the display face angle to 5° and in most cases will not need to be adjusted. However, if adjustment is needed, refer to **Adjust Display Face Angle (p.20)**.

7. Move to the rear of the table and stand at the center of the tabletop.
8. Grab the bottom edge of the tabletop with both hands spread slightly wider than shoulder width apart and lift the tabletop. Refer to **Figure 24**.

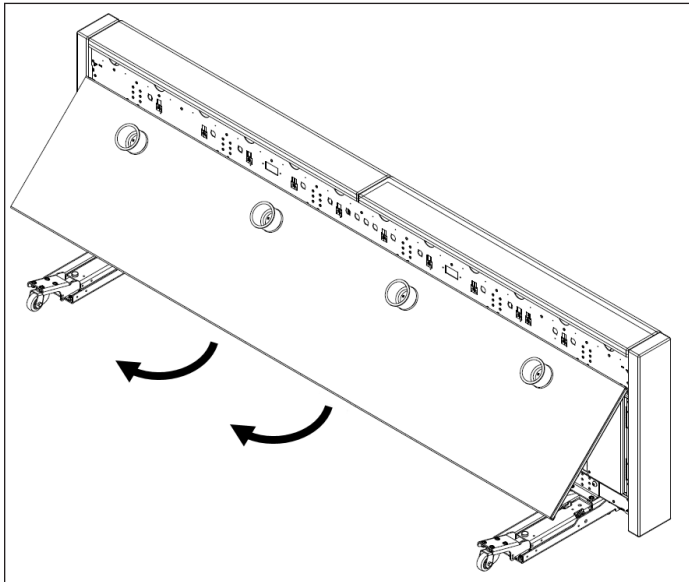

Figure 24: Lift up Tabletop

9. Lift up the tabletop until the latches underneath spring into position. **Figure 25** shows tabletop locked in position.

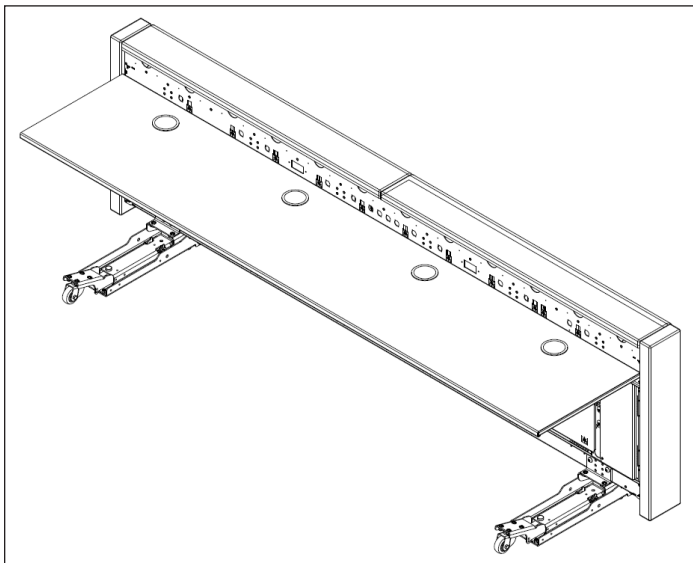

Figure 25: Tabletop Locked in Position

Note: Pull the handle on the right side underneath the tabletop to help ensure latches are fully engaged. Listen for an audible click to indicate that the latches are engaged.

10. Visually inspect each latch underneath the tabletop to ensure it is fully engaged. Refer to **Figure 26**. Apply firm pressure to the tabletop at each support location for additional verification that it is locked in place.

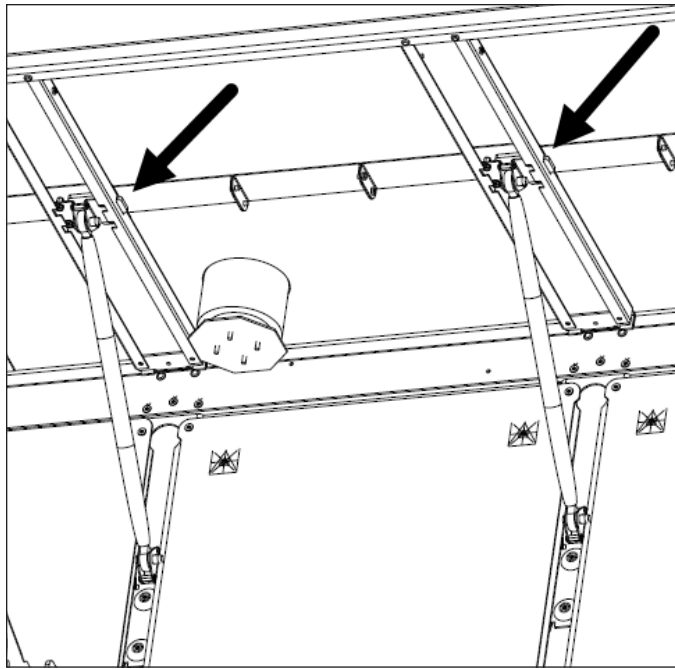

Figure 26: Ensure All Latches Engaged

11. Locate the lockout lanyard hanging off the far-right support underneath the tabletop (**Figure 27**), and clip it through the hole just in front of the sliding latch (**Figure 28**).

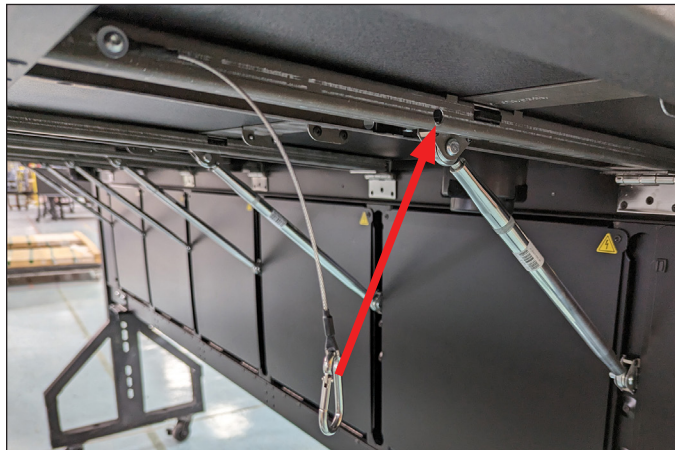

Figure 27: Lockout Lanyard



Figure 28: Lockout Lanyard Engaged

12. Move to the left side, and repeat **Step 11** to engage the second lockout lanyard.
13. Repeat **Steps 1–12** for all scorers tables.

Mechanical Installation

Table Teardown – Stationary to Transport Mode

1. Unclip both lockout lanyards and allow them to hang freely. Refer to **Figure 27**.
2. While supporting the tabletop with your right hand, use your left hand to feel underneath the left edge of the tabletop to find the release handle.
3. Pull the tabletop release handle toward the outer edge, and gently lower the tabletop into the dropped position. Refer to **Figure 29**.

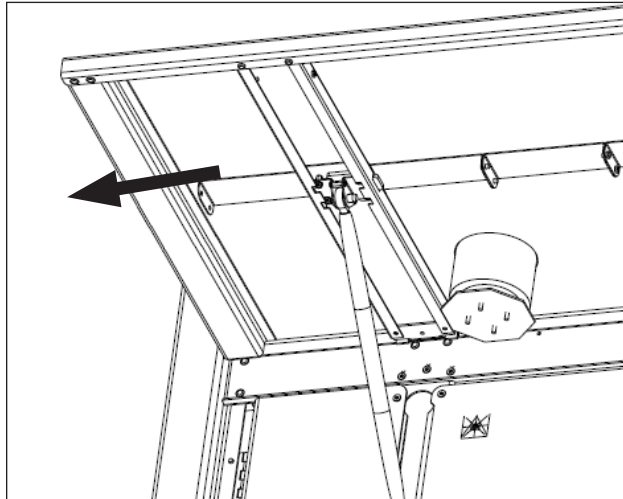

Figure 29: Tabletop Release Handle

4. Tilt the display face forward just far enough to **remove the Caster Base Tool** from the top of each caster base pivot arm. Set the Caster Base Tools aside, and carefully let the display face tilt all the way backward. Adjust cup holders as needed to ensure the tabletop can be pushed flush against the display cabinet. Refer to **Figure 21**.
5. Grab and lift up on the rear of the left caster base pivot arm to raise that side of the table off the floor. Refer to **Figure 30**. Again, the tabletop should be pushed up flush against the rear of the display cabinet to be secured in place by the pivot arms.

CAUTION! Keep fingers/thumb clear between the top of the pivot arms and tabletop surface to avoid being pinched.

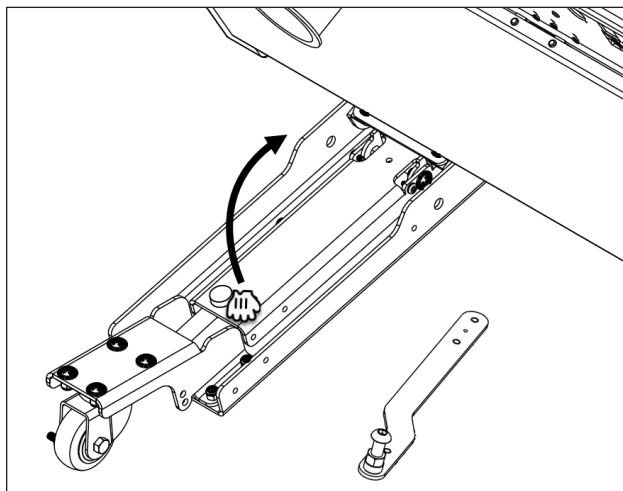

Figure 30: Raise Pivot Arm (Left Caster Base)

6. Move to the right side caster base pivot arm and repeat **Step 5** to fully lift the table off the floor. Refer to **Figure 31**.

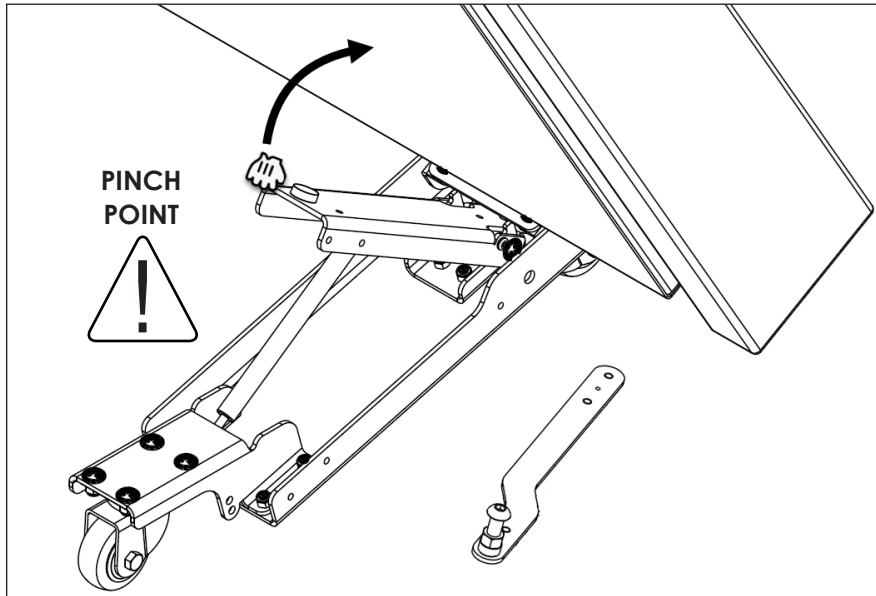

Figure 31: Raise Pivot Arm (Right Caster Base)

7. Place the Caster Base Tools back in the bottom channel of each caster base. Refer to **Figure 13**.
8. At this point, the table is back in transport mode and can be moved to storage or an alternate location. Refer to **Figure 32**.

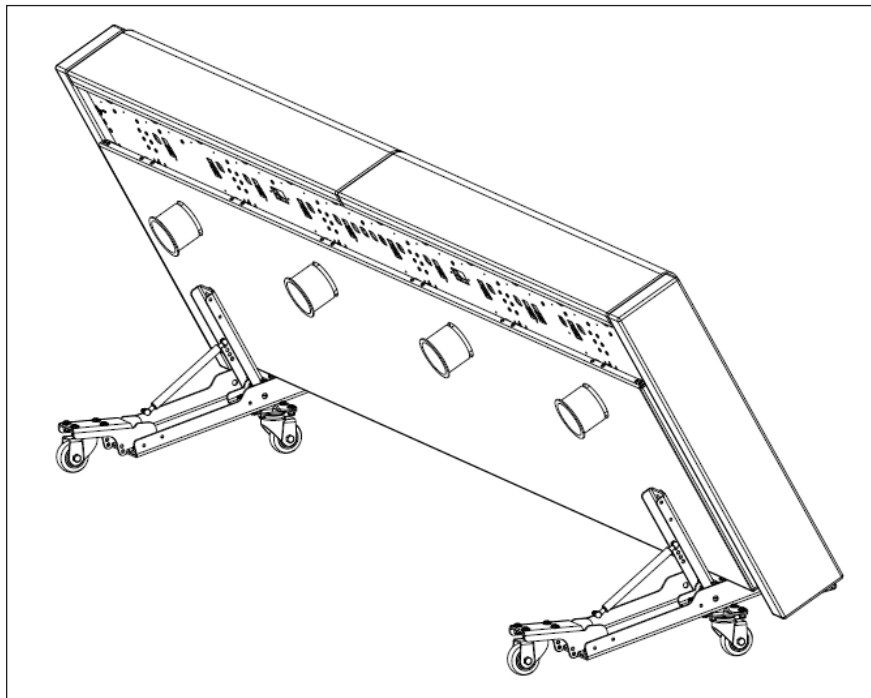

Figure 32: Transport Mode

Adjust Tabletop Level

The tabletop supports are turnbuckle-style connecting rods that will allow for fine tuning of the tabletop to be level across its width and in relation to the floor. Refer to **Figure 33**.

- To **raise** the tabletop, rotate the turnbuckles **counterclockwise** by hand until the desired height is achieved. Maximum adjustment is 16" pin to pin, or +1" from factory.
- To **lower** the tabletop, rotate the turnbuckles **clockwise** by hand until the desired height is achieved.

Verify that all turnbuckles are the same overall length from pin to pin by measuring with a tape measure. This ensures proper tabletop operation when raising/lowering.

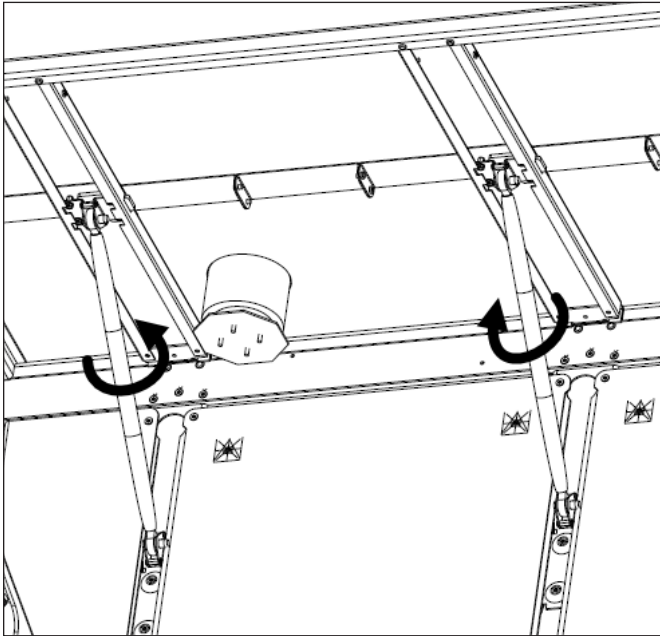

Figure 33: Turnbuckle Adjustment

Troubleshooting Inconsistent Latches:

All latches should function together. From continued use, it is possible one or more latches may not engage. With the tabletop in intended latched position, verify all cabinet-side turnbuckle positions are all the way down against the stops. Adjust the disengaged latch's turnbuckle to return proper function. The factory length is 15" pin-pin on the turnbuckle assembly.

Multiple Table Connection

If more than one scorers table is to be used as part of a single display face, they must be lined up in the appropriate arrangement and connected together. One table attaches to another using two latches on the right side of the table (as viewed from the rear) and the provided 5/16" T-handle hex wrench (part # TH-1088).

To attach the tables together, follow the steps below:

1. Locate the section number on either side of the table. Refer to **Figure 34**. The farthest right table (when viewed from the rear) will typically be labeled "101", then the next table to its left will be "102", and so on.

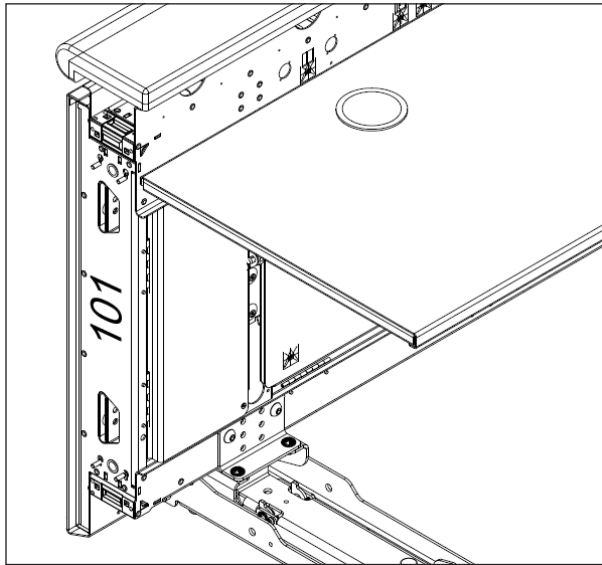

Figure 34: Section Number Label Location

2. Move the table labeled "101" into position, set the Caster Base Tool in place, and lift up the tabletop as described in **Table Setup – Transport to Stationary Mode (p.9)**.
3. Position the tables together as described below and shown in **Figure 35**:
 - a. Move the table labeled "102" into position as close as possible to the right side of table "101" (as viewed from the front).
 - b. Lower the end of table "102" farthest from table "101".
 - c. Lower the end of table "102" closest to table "101".

Note: If the tables are overly difficult to reposition, try adjusting the front and rear caster wheels as shown in **Figure 18** and **Figure 22**.

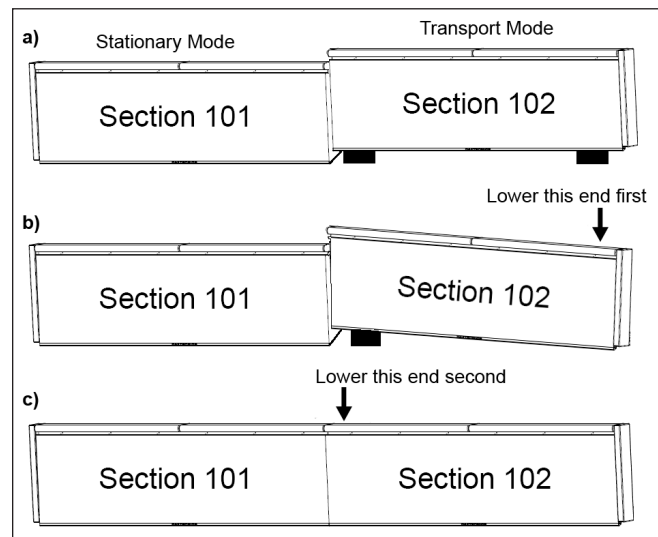

Figure 35: Multiple Table Positioning

4. With the table labeled "102" in position, set the Caster Base Tool in place, and lift up the tabletop as described in **Table Setup – Transport to Stationary Mode (p.9)**.

- Using the provided 5/16" T-handle hex wrench, latch both latches on the left table to the right table (as viewed from the rear). The wrench must be rotated 285° or a little over a 3/4 turn to fully engage the latch. Refer to **Figure 36** for the location of these latches and proper T-handle wrench rotation. If it is difficult to turn the T-handle wrench, verify tables are pushed tightly together and aligned front-back.

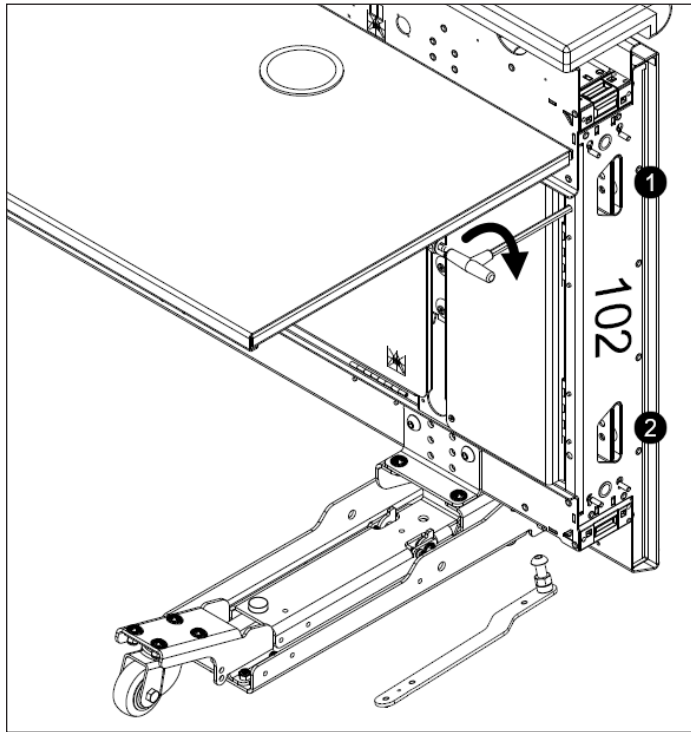

Figure 36: Latch Locations and T-Handle Wrench

- Repeat **Steps 2–5** for all remaining tables. Store the T-handle hex wrench in a convenient location, such as inside the cable tray.

Note: Be sure to unlatch all tables from each other before performing the steps in **Table Teardown – Stationary to Transport Mode (p.14)**.

Attach End Pads

To keep players safe and protect the table from damage, end pads **must be attached** any time the table is in use during games and events.

The left- and right-side end pads are identical in shape and attach in the same manner. Each pad is marked with an "L" or an "R" to indicate which side of the table it will attach to (as viewed from the front). The example shown in **Figure 37** is a right-side pad, but left-side pads will attach the same way.

To attach the end pads, follow these steps:

- Position the end pad at the end of the section. Four bolts attached to each end pad align with keyhole cutouts in the table frame.
- Lift the pad up so all four bolts may be inserted into the keyhole cutouts. It is critical that all four bolts are positioned properly so they hold the pad securely onto the end of the table.
- Slide the pad downward in the side of the frame after all four bolts are properly positioned in the keyhole cutouts. This secures the end pad onto the table.

4. Verify all four bolts are hooked securely into the end of the table to prevent damage to the end pad or possible injury to a player.

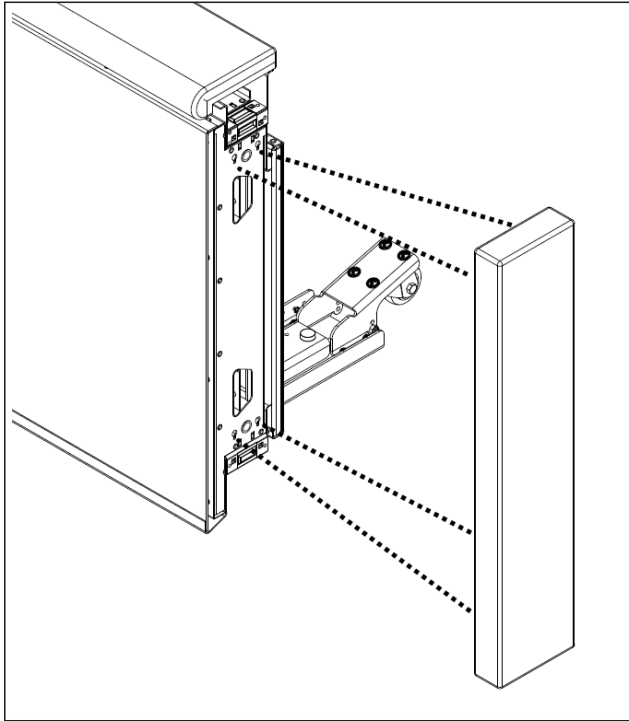

Figure 37: Align End Pad Bolts with Keyhole Cutouts

5. Repeat **Steps 1–4** for the end pad at the opposite end of the table.

To remove an end pad, lift it up and pull it away from the table.

Attach Top Pads

1. Locate one of the top pads. Each table has two top pads regardless of width.
2. Line up the hinges on the pads with the mating hinges on top of the table.
3. Use a small pick or screwdriver to engage both spring pins on each hinge and connect the pad to the table. Refer to **Figure 38**.

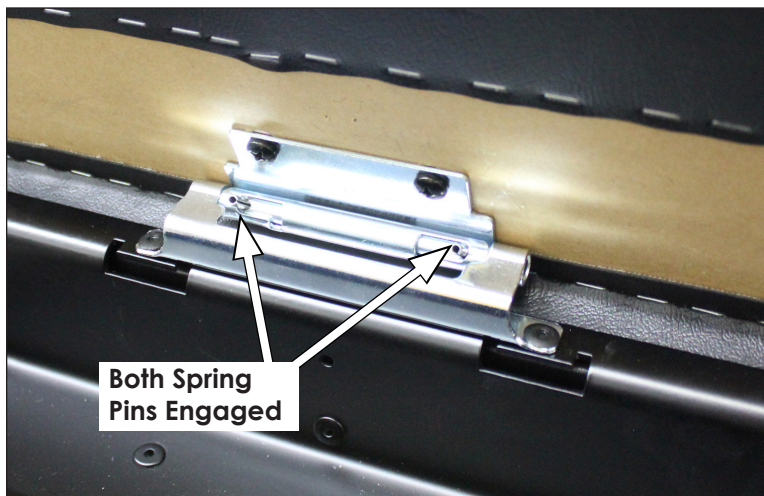

Figure 38: Top Pad Hinge

4. Repeat **Steps 1–3** for the other top pad.

Adjust Display Face Angle

All display face angles are pre-set at the factory to 5°. Adjustment of this angle is typically only needed if the protective face panel causes unwanted glare for TV cameras. If a different face angle is desired, the Caster Base Tools and the tabletop surface must be adjusted.

1. Locate one Caster Base Tool in the bottom channel of one caster base.
2. Use the provided 5/16" T-handle hex wrench (part # TH-1088) to turn the adjustment bolt clockwise to increase the display face angle (tilt the face farther back), or counterclockwise to decrease the display face angle (tilt the display farther forward). Refer to **Figure 39**.

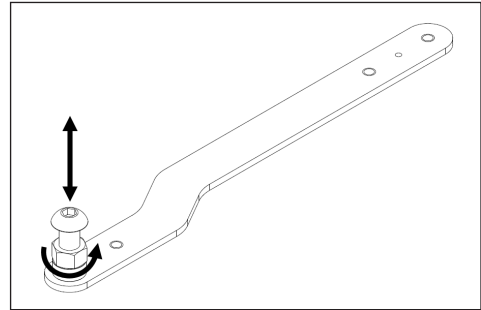

Figure 39: Adjustment Bolt and Jam Nut

Face angle is adjustable from a minimum of 0° to angled back 15°. Use a measuring device to set the adjustment bolt at the correct height to correspond with the typical face angles as shown below and in **Figure 41**:

- 1) 0° – 1-5/8" (fully vertical, perpendicular with floor)
 - 2) 5° – 1-1/4" (as set from factory)
 - 3) 10° – 13/16" (bolt head will be flush with jam nut)
 - 4) 15° – 3/8" (completely remove jam nut)
3. Once the desired face angle is achieved, set the jam nut and use the 5/16" T-handle wrench to lock the adjustment bolt in place.
 4. Repeat **Steps 1–3** for **every** Caster Base Tool for **every** table that is to be connected together as a single display.

After adjusting the Caster Base Tools to change the face angle, the tabletop must also be adjusted accordingly by moving the slide stops. Refer to **Figure 40**.

Note: If possible, have someone assist by lifting up slightly on the tabletop to support it while the slide stops are being adjusted. Alternately, depress the latch on the latch slider corresponding to the slide stop being adjusted. This will allow the latch slider to freely slide back in the tabletop support.

1. Use a T25 Torx bit to remove the two M5 flathead screws.
2. Move the slide stop up as the face angle increases or down as the face angle decreases as shown below and in **Figure 41**:

- 1) Lowest Position, 0° (fully vertical)
- 2) ≤ 5° (as set from factory)
- 3) ≤ 10°
- 4) Highest Position, ≤ 15°

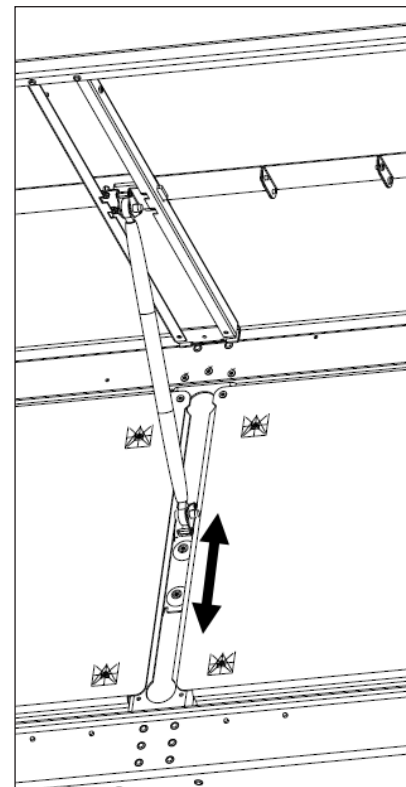

Figure 40: Slide Stop

Note: The farther back the face is tilted, the higher the slide stops should be set.

3. Re-install the two M5 flathead screws.
4. Repeat **Steps 1–3** for **every** slide stop for **every** table that is to be connected together as a single display.

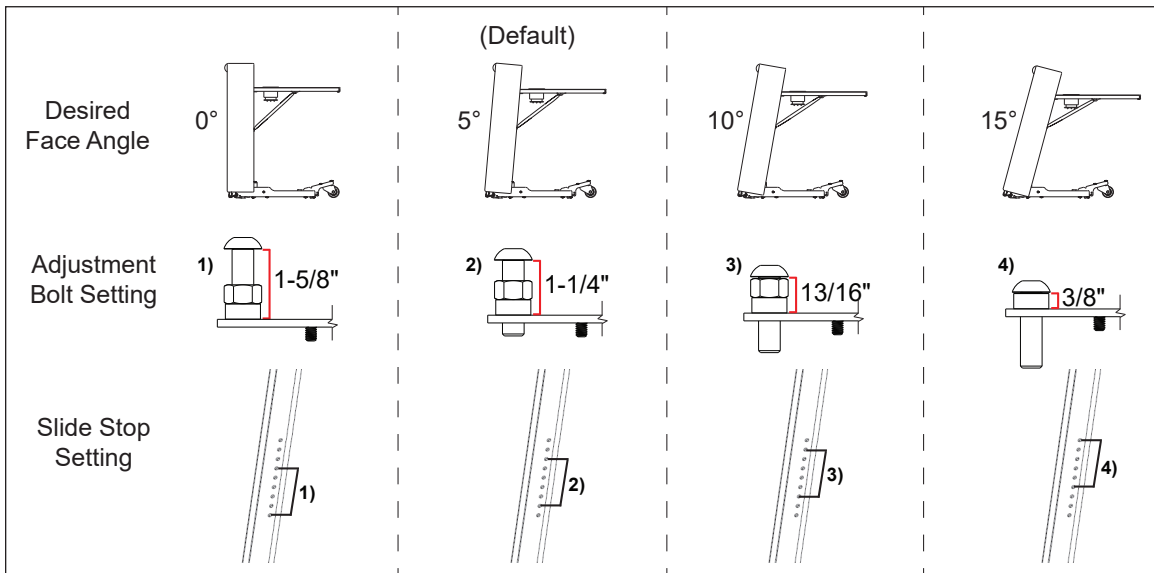

Figure 41: Face Angle Adjustment

Notice that as the face angle increases – i.e. tilts farther back – the adjustment bolt position lowers, and the slide stop position rises.

4 Electrical Installation

This scorers table system is intended to be installed in accordance with the requirements of Article 600 of the National Electrical Code and/or other applicable local codes. This includes proper grounding and bonding of the sign. This display is suitable for dry locations only. Only qualified individuals should terminate power and signal cable and access the electrical components of this display and its associated equipment.

Warnings and Disclaimers

- Ensure that all electrical work meets or exceeds all local or national electrical codes.
- Provide the required power to the display as listed on the product labels, specifications, or site-specific riser drawings. The conductor size may vary based on the length of the power run.
- Consider implementing a separate circuit for the display using an isolation transformer or dedicated transformer.
- Daktronics assumes no liability for any issues caused by line voltage fluctuations or other improper power conditions.

Power Summary

Power from the power cords routes to the Power In jack on the power supplies. From there, power routes to the individual modules. ProLink Routers (PLRs) are powered by the closest available module. Refer to the appropriate Riser Diagram for detailed power information. Refer to the tables below for power specifications. Note that powers include 10A for convenience outlets.

ST-3100-3.9MN	ST-3100-5.9MN	120V~ -1P 60 Hz, 2W + GND @2		
Section	Section	Watts	Cord 1 Amps	Cord 2 Amps
3x8 – 192x512	3x8 – 126x336	2220	8.5	10
3x10 – 192x640	3x10 – 126x420	2472	10.7	10
3x12 – 192x768	3x12 – 126x504	2724	12.8	10

Each table requires two 20A dedicated circuits.

Signal Summary

Depending on display application and control room design, display data may route from the control room to the display by a number of different pieces of equipment. The most common are the ProLink6 control system, the A/B transmitter interface, and the Display Interface (DI) video interface.

The Block Diagrams in **Appendix A** illustrate the signal layout of each section of the display. The Riser Diagram illustrates the signal connections from the control room to ProLink Routers (PLRs) in the display or from section to section of the display.

Data from the control system routes via fiber-optic cable from Fiber Port A on the DI to a PLR in the display. Refer to the **DI-6000 & VP-6000 Series Processor Operation Manual (DD3953772)** for details. The DI may be located inside the display or in the control room or other remote location. Refer to the appropriate Riser Diagram for more routing information.

The Riser Diagrams illustrate the fiber layout from section to section of the display.

The Block Diagrams in **Appendix A** illustrate how data passes from one PLR to the modules and depict power harnessing and component placement.

Each PLR sends data to the modules within the display. Refer to the Block Diagrams in **Appendix A** for routing information. Signal exits via fiber-optic cable from Fiber Port B on the PLR and routes to Fiber Port A on the next PLR. **Figure 42** illustrates a typical signal routing layout. Refer to the appropriate Riser Diagram for further information.

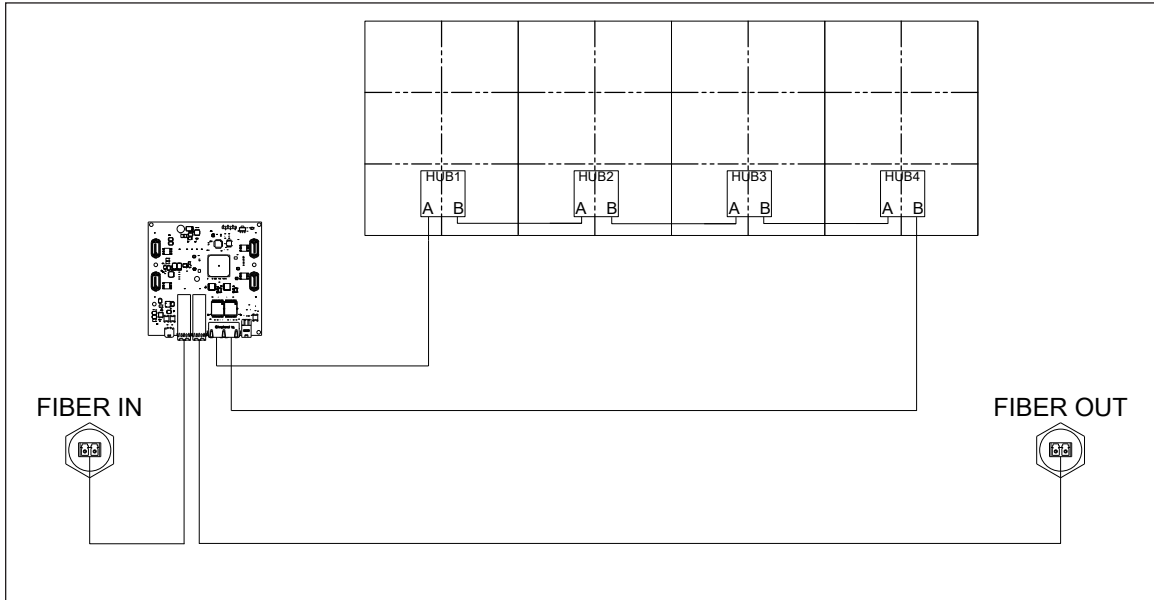

Figure 42: Signal Routing

Fiber-Optic Connectors

LC connectors are square. To remove an LC connector, depress the small clip on the jack and gently remove. Refer to **Figure 43** and **Figure 44**. When pulling a connector from a plug, pull the jack itself, not the wire or cable. Pulling the wires may damage the connector.



Figure 43: LC Industrial Fiber-Optic Connector

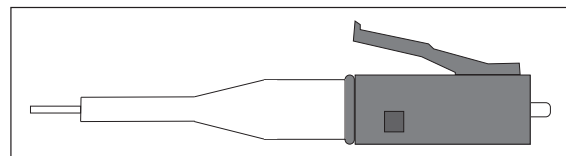

Figure 44: LC Fiber-Optic Connector

Control Cable

Refer to the appropriate Riser Diagram for specifications on signal and power cable runs. Refer to the **DI-6000 & VP-6000 Series Processor Operation Manual (DD3953772)** for more information on the Display Interface (DI).

The minimum bend radius for this fiber-optic cable is 15 times the outside diameter of the cable or 7" (178 mm). Refer to the appropriate Riser Diagram for the outside diameter of the cable in this system. All fiber-optic runs must be continuous except where noted on the Riser Diagram.

Display Power

All display grounding, power routing, and termination must meet or exceed local codes and standards.

Correct power installation is imperative for display operation. These subsections give details on display power installation. Only qualified individuals should attempt the electrical installation; untrained personnel should not attempt to install displays or any of the electrical components. Improper installation could result in serious equipment damage and could be hazardous to personnel.

The socket outlet must be installed near the equipment in an easy-to-access location.

Ensure all external overcurrent protection meets all local and national electrical codes and is appropriately sized to the load of the sections it is terminating.

Refer to the contract-specific documentation to determine who is responsible for providing conduit and pulling cable through the conduit.

Grounding

All components of a display system – including but not limited to displays, control equipment, and connected peripheral equipment – must be electrically grounded. Only qualified individuals may perform electrical work, including verification of ground resistance. Daktronics is not responsible for improper grounding or damage incurred as a result of improper grounding.

Grounding methods must meet the provisions of all applicable local and national codes. Inspect and verify all grounding methods meet the provisions of all applicable local and national codes.

Proper grounding is necessary for reliable equipment operation and general electrical safety. Failure to properly ground the display system may void the warranty, disrupt operation, damage equipment, and cause bodily harm or death.

Convenience & USB Outlets

Scorers tables are equipped with 6, 8, or 10 convenience outlets, depending on the table's width, for plugging in control equipment and other small electronic devices. A 10 Amp resettable breaker limits the total convenience outlet power draw. Tables also feature 8 USB outlets (2 outlets with 4 ports each) to power cellphones, tablets, and other equipment with USB chargers.

Refer to the Block Diagrams in **Appendix A** for outlet and resettable breaker locations.

Display Wiring

Power Cables

Each table requires two power cables (provided by Daktronics) which are available in 25' (7.6 m), 50' (15.2 m), or 75' (22.9 m) lengths.

The power cables use a NEMA® L5-20P plug to connect to a mating NEMA® L5-20R receptacle (not provided) in the wall/floor box. Refer to **Figure 45**. Refer to the appropriate Riser Diagram for details on who is supplying the mating L5-20R receptacle.



Figure 45: Power Connectors

Use a T25 Torx bit to remove the screws securing the lower-right access panel under the tabletop. Connect both power cables to the **120V AC IN** jacks. Refer to **Figure 46**.

Signal Cables

Route the fiber cables based on the appropriate Block Diagram, Config Drawing, and Riser Diagram in **Appendix A**.

Interconnect Cables with Embedded Controller

Tables with an embedded control system allow the operator to connect the Show Control computer into a network jack right on the table. Refer to the appropriate Riser Diagram, **Figure 47**, and **Figure 48** for connection details.

Fiber Connections

- **VIP FIBER OUT** to **FIBER IN** on the same table using fiber jumper (part # W-1767) – only used on the first table in a row of tables
- **FIBER OUT** to **FIBER IN** between tables (if required)

Network Connections

- **NETWORK IN** from control location; may also connect via **DAK NETWORK** convenience outlets
- **INTERNET IN** from modem; provides Internet access to the **DAK NETWORK** convenience outlets
- **NETWORK OUT** to **NETWORK IN** between tables (if required) – only used when multiple tables with embedded controllers are connected together

Interconnect Cables with External Controller

Tables with an external control system will be operated remotely from a separate control room location. Refer to the appropriate Riser Diagram, **Figure 47**, and **Figure 48** for connection details.

Fiber Connections

- **FIBER IN** from the DI at the control location or local fiber J-box
- **FIBER OUT** to **FIBER IN** between tables (if required)
- **VIP FIBER OUT** – not used

Network Connections

- **INTERNET IN** from modem; provides Internet access to the **DAK NETWORK** convenience outlets
- **NETWORK OUT** – not used



Figure 46: Power IN



Figure 47: Inputs



Figure 48: Outputs

End-of-Period and Clock Stop Light Strip Kits

Reference Drawings:

Light Strip Attachment DWG-4889870

Daktronics scorers tables may have optional End-of-Period (EOP) light strips running along the bottom front of the table that illuminate at the end of the period. Tables may also feature Clock Stop light strips along the rear cable tray. EOP light strips are typically factory installed, while rear Clock Stop light strips must be installed on site using clips and screws as described in **DWG-4889870**.

1. Set the All Sport® control console on the tabletop and plug the power cord into one of the rear convenience outlets.
2. Connect the 10' (3 m) 1/4" phone signal cable (part # W-1340) from **J1**, **J2**, or **J3** on the control console to the **SIGNAL IN** jack located behind the right rear access door of the primary table. Refer to **Figure 49**.

Note: For the Clock Stop light strip, plug the 3-pin XLR cable into the rear **CLK STOP OUT** jack just above the tabletop. Refer to **Figure 50**. Store excess cable in the cable tray beneath the top pad.

3. For multiple tables with light strips, connect 3' (0.9 m) 3-pin XLR cables (part # 0A-1313-0114) from the XLR outputs to the XLR inputs between the tables.
 - The **EOP OUT** and **CLK STOP OUT** jacks are located behind the left rear access doors as shown in **Figure 51**.
 - The **EOP IN** and **CLK STOP IN** jacks are located behind the right rear access doors as shown in **Figure 49**.
4. Power on the control console and enter the appropriate sport code found on the keyboard overlay and in the All Sport® manual listed in **Light Strip Controllers (p.2)** to test the light strips.



Figure 49: Light Strip Inputs



Figure 50: Rear Clock Stop Jack



Figure 51: Light Strip Outputs

Possession Indicator

Daktronics scorers tables may have an optional possession indicator that sits atop the table padding. Refer to **Figure 52**. Possession indicators are designed so they can be positioned anywhere along the length of the top pad to best align with the center of a single table or a row of tables.

Possession indicators mount to the top pad by sliding on from the rear and then using a #2 Phillips screwdriver or 5/16" socket to tighten the set screws on the bottom flange. Plug the power cord into the dedicated convenience outlet labeled **POSS. INDICATOR OUTLET ONLY**. Refer to **Figure 53**. To operate, simply flip the switch on the back of the unit toward the side of the court that has possession, and the LED indicators will illuminate on both the front and back of the unit.

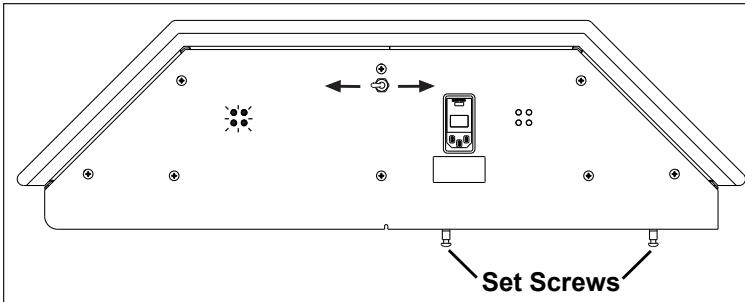

Figure 52: Possession Indicator, Rear View



Figure 53: Possession Indicator Outlet ONLY

Display Power Up

1. Turn on the main disconnect and plug in the power cords to power up the display.
2. Power up the control system to ensure it is fully operational before proceeding.
3. Run an initialization/power-up script or animation/logo on the display.

5 Maintenance & Troubleshooting

Turn off power before performing any repair or maintenance work. Only qualified service personnel may access internal electronics.

Daktronics product managers' engineering staff must approve any changes that may affect the display's structural integrity. If any changes are made to the display, submit detailed drawings to Daktronics engineering staff for evaluation and approval, or the warranty will be null and void.

Recommended Tools

When performing maintenance work on the display, Daktronics recommends using the following tools and placing them in a convenient, easy-to-use location.

Tool	Part Number	Use
Phillips Screwdriver	TH-1061	Removes hub board/receiver card; removes PLR from mounting bracket; removes power supply connectors
T25 Torx Bit	TH-1118	Opens rear access panels and removes front face
5/16" Nut Driver	TH-1156	Removes power supplies
5/16" T-handle Wrench	TH-1200	Engages table interconnect latches
Module Magnet Tool	TH-3786574	Removes modules
T20 Torx Bit	TH-4109429	Removes PLR mounting bracket from display

The only tools provided with the table are the T-handle wrench and Module Magnet Tool. Additional replacement tools may be ordered directly from Daktronics. Refer to **Daktronics Exchange and Repair & Return Programs (p.37)**.

Front Access

1. Disconnect the power to the display.
2. Locate the component to remove on the Block Diagram drawing in **Appendix A**.
3. To access the face panel screws, lift up one top pad and use a small pick or screwdriver to depress both spring pins on each hinge connecting the pad to the table. Pull the spring pins inward and down. Refer to **Figure 54**.
4. Remove the pad and set it aside; repeat for all top pads.
5. To access the modules, remove all T25 Torx screws along the top flange of the face panel as shown in **Figure 55**.



Figure 54: Remove Top Pad Hinges



Figure 55: Remove Torx Screws

6. Tilt the face panel forward and lift up to remove. Refer to **Figure 56**.

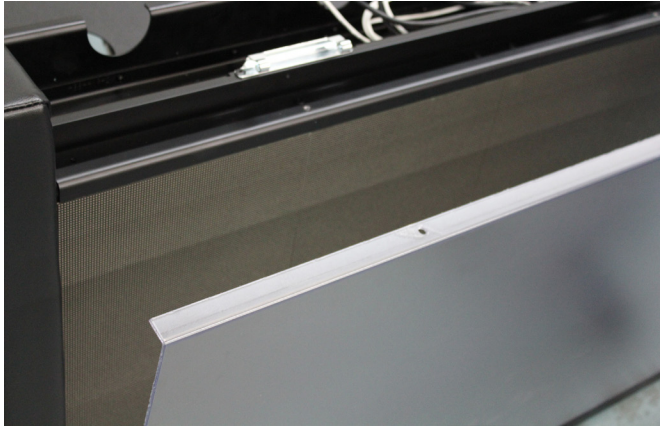

Figure 56: Tilt Face Panel Forward and Remove

7. Locate the module or corresponding component behind it to be removed, and use the Module Magnet Tool (part # TH-3786574) to pull the magnets away from the module mounting sheet:
 - a. Turn the knob on the module removal tool clockwise to disengage the tool.
 - b. Center the tool on the face of the module to be removed, and turn the knob on the tool counterclockwise to engage the magnets. Refer to **Figure 57**.
 - c. Carefully pull the module straight out until it disengages from the display face. Refer to **Figure 58**.

Note: Refrain from attaching the module removal tool to any highly magnetic objects, as it is difficult to disengage the tool from these objects.

8. If the module was the only component that needed to be replaced, simply insert the new module into the display (noting the rear markings for correct orientation), and then reattach the protective face panel and top pad.
9. With all necessary modules removed, press and hold the push button at the top of the component front-access assembly. Refer to **Figure 59**.



Figure 57: Engage Module Magnet Tool



Figure 58: Remove Module

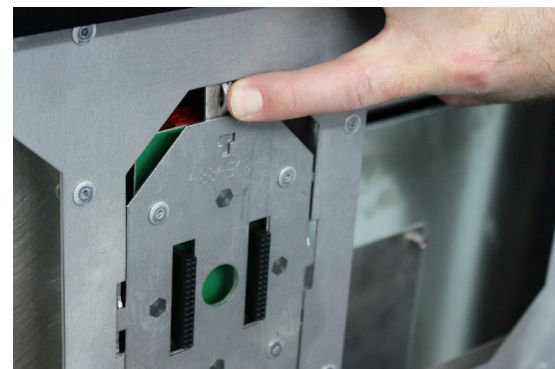

Figure 59: Front-Access Assembly Push Button

10. Slide the assembly up, and pull the bottom outward until the top tab is free. Refer to **Figure 60**.



Figure 60: Remove Front-Access Assembly

11. Gently pull the component front-access assembly from the module mounting sheet to expose the harnesses.

Hub Board/Receiver Card Replacement

1. Follow **Steps 1–11 in Front Access (p.28)** to remove the protective face panel, modules, and component front-access assembly.
2. Disconnect the Cat 6 cables from the RJ45 jacks on the hub board. Refer to **Figure 61**.
3. Disconnect the power supplies from the hub board by pushing in the positions on the spring-loaded terminal blocks and disconnecting the cables extending from the board. Refer to **Figure 61**.
4. Use a Phillips screwdriver to remove the screws securing the hub board to the component front-access assembly.
5. Install a new hub board.
6. Reinstall the component front-access assembly.
7. Reinstall the modules removed to access the component, noting the rear markings for correct orientation.
8. Reattach the protective face panel and top pad.
9. Power on and test the display to verify the issue has been resolved.

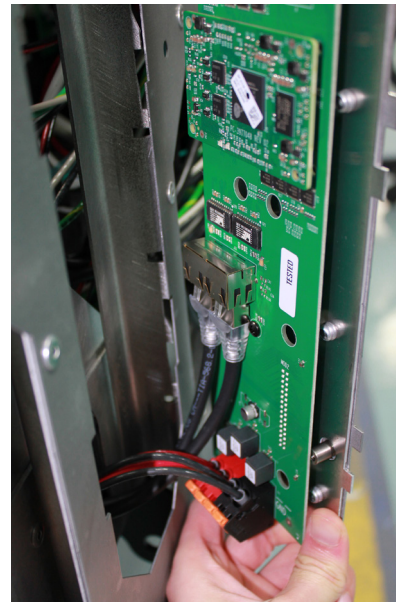

Figure 61: Disconnect Cables from RJ45 Jacks & Terminal Blocks

Power Supply Replacement

1. Follow **Steps 1–11 in Front Access (p.28)** to remove the protective face panel, module(s), and component front-access assembly.
2. Use a Phillips screwdriver to loosen and remove the power cables extending from the power supply.
3. Use a 5/16" nut driver to loosen the screws holding the power supply bracket to the display. Remove the power supply and bracket from the display by lifting the bracket up and out of the keyhole mounts.
4. Install a new power supply and bracket.
5. Reinstall the component front-access assembly.
6. Reinstall the modules removed to access the component, noting the rear markings for correct orientation.
7. Reattach the protective face panel and top pad.
8. Power on and test the display to verify the issue has been resolved.

Rear Access

1. Disconnect the power to the display.
2. Locate the component to remove on the Block Diagram drawing in **Appendix A**.
3. Lift the tabletop upward and secure in place as described in **Table Setup – Transport to Stationary Mode (p.9)**.
4. Use a T25 Torx bit to remove the two screws securing the appropriate access door.
5. Carefully allow the access door to lower downward into the open position.

Power Supply Replacement

1. Follow **Steps 1–5 in Rear Access (p.31)** to access the power supply.
2. Use a Phillips screwdriver to loosen and remove the power cables extending from the power supply.
3. Use a 5/16" nut driver to loosen the screws holding the power supply bracket to the display. Remove the power supply and bracket from the display by lifting the bracket up and out of the keyhole mounts.
4. Install a new power supply and bracket.
5. Use a T25 Torx bit to close the access door.
6. Power on and test the display to verify the issue has been resolved.

Components

Power Supply

Figure 62 illustrates a typical power supply, also referred to as a power module. The power supply mounts to the display on a mounting plate. The power harnesses connected to the unit vary depending on power supply type and overall display application.

Caution! Disconnect display power before servicing the power supplies to avoid electrical shock. The power supplies run on high voltage and may cause physical injury if touched.



Figure 62: Power Supply

ProLink Router (PLR)

Figure 63 illustrates a ProLink Router (PLR). The PLR is a display interface board that passes display data from the ProLink6 control system modules and other PLRs.

Refer to the **PLR 6X5X Installation & Maintenance Manual (DD1735784)** for further information.

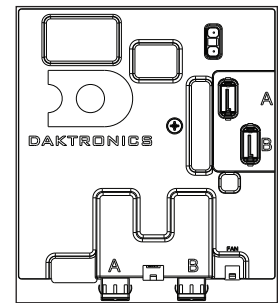

Figure 63: PLR

Digital Media Player (DMP)

Figure 64 illustrates a Digital Media Player (DMP). The DMP is a device primarily intended to store or deliver content files to a display directly through an intermediate device, such as a processor or a signal converter. The DMP may be located inside the scorers table or in a separate control location.



Figure 64: DMP

Refer to the **DMP-5000/8000 Series Digital Media Player Operation Manual (DD1881645)** for further information.

Display Interface (DI)

Figure 65 illustrates a Display Interface (DI). The DI is an interface that drives content to the display while also dimming, providing gamma and color controls, and displaying test patterns. The DI may be located inside the scorers table or in a separate control location.

Refer to the **DI-6000 & VP-6000 Series Processor Operation Manual (DD3953772)** for further information.



Figure 65: Display Interface

Light Strip Driver

Scorers tables with optional light strips will include an LED driver to control when the light strips turn on and off. Refer to **Figure 66** to view the location of light strip driver tray in the scorers table.

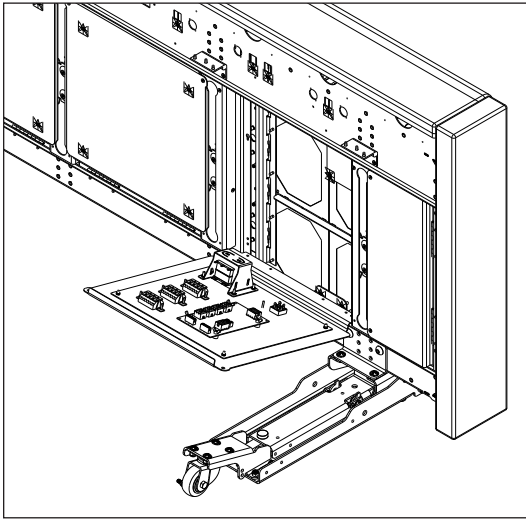

Figure 66: Driver Tray Location

Refer to **Figure 67** for the components of an optional light strip driver tray.

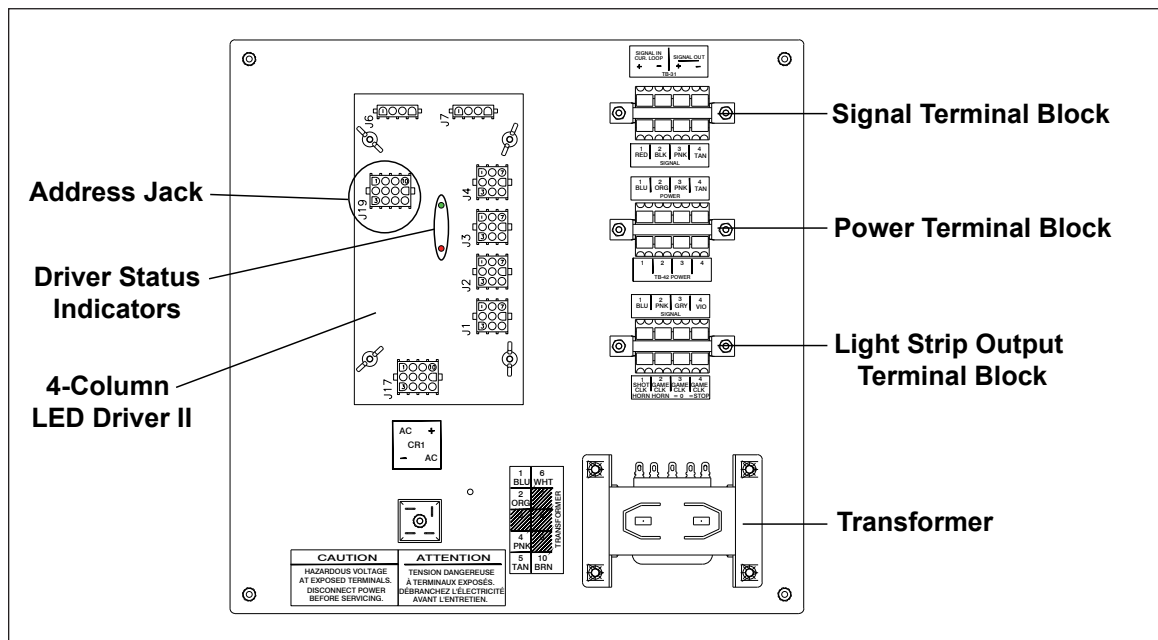

Figure 67: Light Strip Driver Tray Components

The light strip output terminal block determines when the light strips will illuminate. By default, end-of-period light strips are triggered when the game clock equals 0, and clock stopped light strips are triggered when the clock equals stopped. Either type of light strip may instead be set to illuminate when the shot clock horn or the game clock horn sounds. Move the gray and/or violet wire to the appropriate terminal for desired function.

When troubleshooting 4-column driver problems, two diagnostic LED indicators labeled **DS1** and **DS2** provide the following driver status information:

LED	Color	Function	Operation	Summary
DS1	Red	Signal RX	Steady on or blinking	<ul style="list-style-type: none">• On or blinking when driver is receiving signal• Off when there is no signal
DS2	Green	Power	Steady on	<ul style="list-style-type: none">• On and steady when driver is receiving power

Note: While it is necessary to have the display powered on to check the LED status indicators, always disconnect power before servicing.

Replacing a Driver

If the driver status indicators do not appear to be working correctly, it may be necessary to replace the driver.

1. Open the table from the rear as described in **Rear Access (p.31)**.
2. Disconnect all plugs from the driver by squeezing together the locking tabs and pulling the connectors free. It may be helpful to label the cables or take a picture to know which cable goes to which connector when attaching the new driver.
3. Remove the wing nuts securing the driver to the driver tray.
4. Carefully lift the driver from the display and place it on a clean, flat surface.
5. Position a new driver over the screws and tighten the nuts.
6. Reconnect all plugs to the driver. These are keyed connectors and will attach in one way only. Do not force the connections.
7. Ensure the new driver is set to the correct address. This will be the same address as the old driver being replaced. Refer to **Setting the Driver Address (p.34)**.
8. Close and secure the access panel, then power up and test the display to verify the issue has been resolved.

Setting the Driver Address

For the light strip driver to receive signal and function properly, the driver must be set to the correct address.

Optional light strip drivers use Address 1.

This address is set with jumper wires in a 12-pin plug which mates with jack **J19**, located in the upper-right corner of the driver as shown in **Figure 67**. It may be possible to reuse the same address plug from the driver that was replaced. If not, order an **Address 1** plug (part # 0A-1150-0122).

Tabletop Possession Indicators

To replace an optional tabletop possession indicator arrow/colon:

1. Unplug the possession indicator from the designated convenience outlet.
2. Remove the screws securing the possession indicator cover.
3. Disconnect the power/signal cable from the malfunctioning indicator.
4. Use a 1 1/32" nut driver to remove the nuts securing the indicator, and then lift it off the stud inserts.
5. Position a new indicator over the studs (making sure the small plastic spacers are still in place), and then tighten the nuts.
6. Reconnect the power/signal cable, and replace all screws for the indicator cover.
7. Plug the possession indicator back into the designated convenience outlet, then power up and test the display to verify the issue has been resolved.

Troubleshooting

The tables below list potential problems with the display and indicate possible corrective actions. The lists do not include every symptom that may be encountered, but they do present several of the most common situations that can occur.

Display

Display Problem	Troubleshooting Steps
Module is blank or garbled	<ul style="list-style-type: none"> • Check the power status LEDs on all power supplies and modules connected to the module.
Section of display is blank	<ul style="list-style-type: none"> • Ensure the section is receiving power and all breakers are turned on. • Ensure the power status LEDs on the modules, power supplies, and ProLink Routers (PLRs) in the blank section are on. • Ensure the connections to the PLR are secure. Change the connections with one another to test. • Ensure the fiber-optic signal is connected to the PLR or patch panel. • Perform a PLR loopback test to test the PLRs in the section. Refer to the PLR 6X5X Installation & Maintenance Manual (DD1735784) for instructions.
Entire display is blank	<ul style="list-style-type: none"> • Ensure the display is receiving power and all breakers are turned on. When power is applied to the display, power supply LEDs should turn on. • Ensure the Display Interface (DI) is not blank. • Ensure the fiber-optic signal cable is connected to the DI. The input signal should be locked. If the input signal is not locked, check the fiber connections.

Display Problem	Troubleshooting Steps
Entire display is garbled or uncontrollable	<ul style="list-style-type: none"> Use the test patterns to check the DI status LEDs and ensure the board is receiving power. Refer to the DI-6000 & VP-6000 Series Processor Operation Manual (DD3953772) for instructions. Verify the controller/content player configuration and restart the display service. Ensure the fiber-optic signal cable is connected to the DI. The input signal should be locked. If the input signal is not locked, check the fiber connections.

Light Strips

Problem	Possible Cause	Solution/Items to Check
Light strips do not light	No power to the control console	Ensure the console is plugged into a convenience outlet or 120 V power supply.
		Exchange the console with a working console and enter the correct sport code to test. Replace console if necessary.
	No wired signal from the console	Ensure a 1/4" phone signal cable is connected between J1 , J2 , or J3 on the control console and the SIGNAL IN jack located behind the right rear access door.
	Improper connection between tables	Ensure 3-pin XLR cables are connected between all tables with light strips. The XLR input and output jacks are located behind the right and left rear access doors, respectively.
	Incorrect sport code	Ensure the correct sport code is being used. Refer to the console operation manual in Light Strip Controllers (p.2) .
	No signal to driver	Check that the red DS1 LED on the light strip driver lights up when sending commands from the control console. Refer to Light Strip Driver (p.33) .
	No power to driver	Check that the green DS2 LED on the light strip driver remains lit up when the display is powered on. Refer to Light Strip Driver (p.33) .
	Incorrect driver address or function	Check that the light strip driver is set to the correct address or function. Refer to Light Strip Driver (p.33) .

6 Daktronics Exchange and Repair & Return Programs

Exchange Program

The Daktronics Exchange Program is a service for quickly replacing key components in need of repair. If a component fails, Daktronics sends a replacement part to the customer who, in turn, returns the failed component to Daktronics. This decreases equipment downtime. Customers who follow the program guidelines explained below will receive this service.

Before contacting Daktronics, identify these important numbers:

Display Serial Number: _____

Display Model Number: _____

Job/Contract Number: _____

Date Manufactured/Installed: _____

Daktronics Customer ID Number: _____

To participate in the Exchange Program, follow these steps:

1. Call Daktronics Customer Service.

United States & Canada: 1-800-DAK-TRON (325-8766)

Outside the U.S. & Canada: +1-605-275-1040

2. When the new exchange part is received, mail the old part to Daktronics.

If the replacement part fixes the problem, send in the problem part being replaced.

- a. Package the old part in the same shipping materials in which the replacement part arrived.
- b. Fill out and attach the enclosed UPS shipping document.
- c. Ship the part to Daktronics.

3. The defective or unused parts must be returned to Daktronics within 5 weeks of initial order shipment.

If any part is not returned within five (5) weeks, a non-refundable invoice will be presented to the customer for the costs of replenishing the exchange parts inventory with a new part. Daktronics reserves the right to refuse parts that have been damaged due to acts of nature or causes other than normal wear and tear.

Repair & Return Program

For items not subject to exchange, Daktronics offers a Repair & Return Program. To send a part for repair, follow these steps:

1. Call Daktronics Customer Service.

United States & Canada: 1-800-DAK-TRON (325-8766)

Outside the U.S. & Canada: +1-605-275-1040

2. Receive a case number before shipping.

This expedites repair of the part.

3. Package and pad the item carefully to prevent damage during shipment.

Electronic components, such as printed circuit boards, should be placed in an antistatic bag before boxing. Daktronics does not recommend using packing peanuts when shipping.

4. Enclose:

- name
- address
- phone number
- the case number
- a clear description of symptoms

5. Ship to:

Daktronics Customer Service

[Case #]

201 Daktronics Drive, Dock E

Brookings, SD 57006

Daktronics Warranty & Limitation of Liability

The Daktronics Warranty & Limitation of Liability is located at the end of this manual. The Warranty is independent of Extended Service agreements and is the authority in matters of service, repair, and display operation.

Glossary

Display Interface (DI): an interface that drives video to the display while also dimming, providing gamma and color controls, and displaying test patterns.

Hub board: a display interface that distributes power and signal to modules.

Light Emitting Diode (LED): a low energy, high intensity lighting unit.

Module: a display board with LEDs, a driver board or logic card, a black plastic housing, and a module latch assembly. Up to six modules connect to a single hub board.

Module latch: a safety device that mechanically attaches a module to a panel. A steel plate in the latch allows it to be magnetically disengaged with the module removal tool from the front of the display or manually disengaged with the two tabs on the rear of the module. Module latches are used in all tilted displays but may be used in other applications.

Module removal tool: a device that aids in removing a module from a panel by engaging the magnets.

Pixel: the smallest single point of light on a display that can be turned on and off. For LED displays, a pixel is the smallest block of light-emitting devices that can generate all available colors.

Power supply: a display component that converts AC line voltage from the termination panel to low DC voltage for one or more module driver boards. One power supply may power multiple modules.

ProLink Router (PLR): a data interface component that receives a signal from the display control system and converts and distributes the signal to the receiver cards.

Receiver card: a data distribution component that receives information from a PLR and distributes the information through a hub board to the modules. The receiver card mounts to the hub board.

Termination block: an electrical point usually used to connect internal power and signal wires to wires of the same type coming into the display from an external source.

This page intentionally left blank.

A Reference Drawings

Refer to **Resources (p.1)** for information regarding how to read the drawing number. Any contract-specific drawings take precedence over the general drawings.

Reference Drawings:

Schem; Table Top Poss. Indicator w/ Pwr Cord	DWG-3378521
Schematic; 4Col Drvr-16V Clk Stop/EOP Control	DWG-3702158
Block Diagram ST-B1 3x8	DWG-4797965
Block Diagram ST-B1 3x10	DWG-4797966
Block Diagram ST-B1 3x12	DWG-4797967
Block Dgrm; Clk Stop/EOP Light Strip Cntrl	DWG-4800725
Block Diagram Signal; ST-B1 3x8.....	DWG-4804220
Block Diagram Signal; ST-B1 3x10.....	DWG-4804221
Block Diagram Signal; ST-B1 3x12.....	DWG-4804222
Block Diagram; Control, ST-B1	DWG-4805059
Block Diagram; Network Kit, Domestic	DWG-4805597
Riser; ST-31XY, 1 Table Wide	DWG-4856381
Riser; ST-31XY, 2 Table Wide	DWG-4857853
Riser; ST-31XY, 3 Table Wide	DWG-4857865
Riser; ST-31XY, 4 Table Wide	DWG-4857875
Mechanical Spec, ST-3100	DWG-4865593
Shop; ST-3130, 126X504-5.9/192X768-3.9	DWG-4874201
Shop; ST-3130, 126X1008-5.9/192X1536-3.9	DWG-4879040
Shop; ST-3130, 126X1512-5.9/192X2304-3.9	DWG-4879041
Shop; ST-3130, 126X2016-5.9/192X3072-3.9	DWG-4879042
Light Strip Attachment	DWG-4889870

This page intentionally left blank.

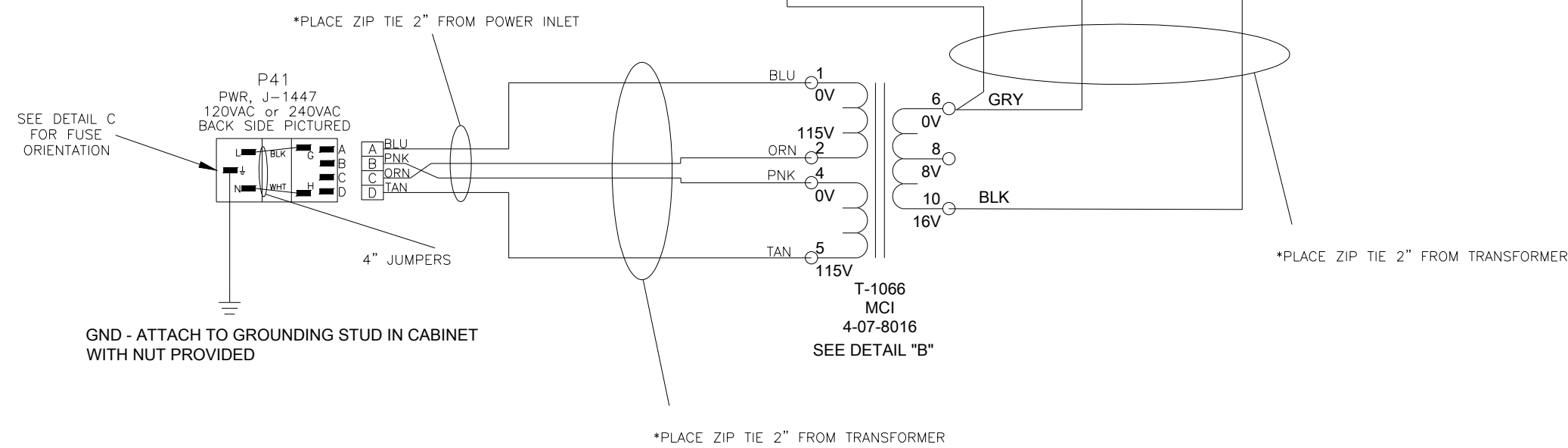
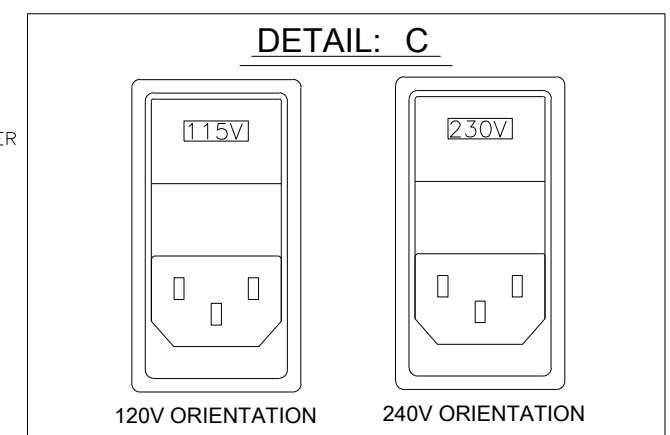
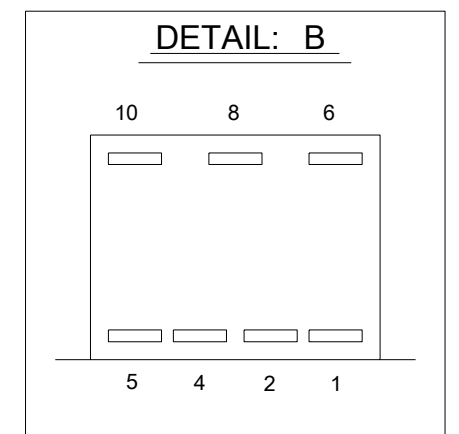
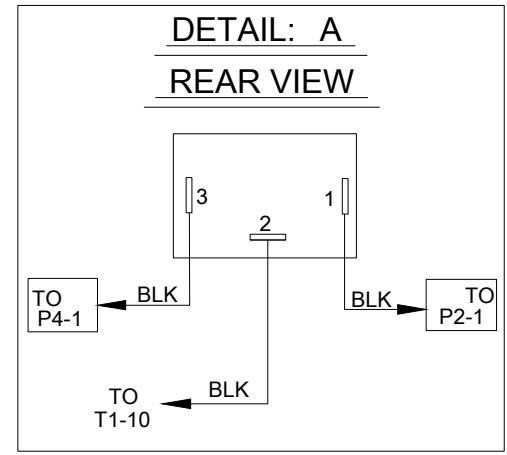
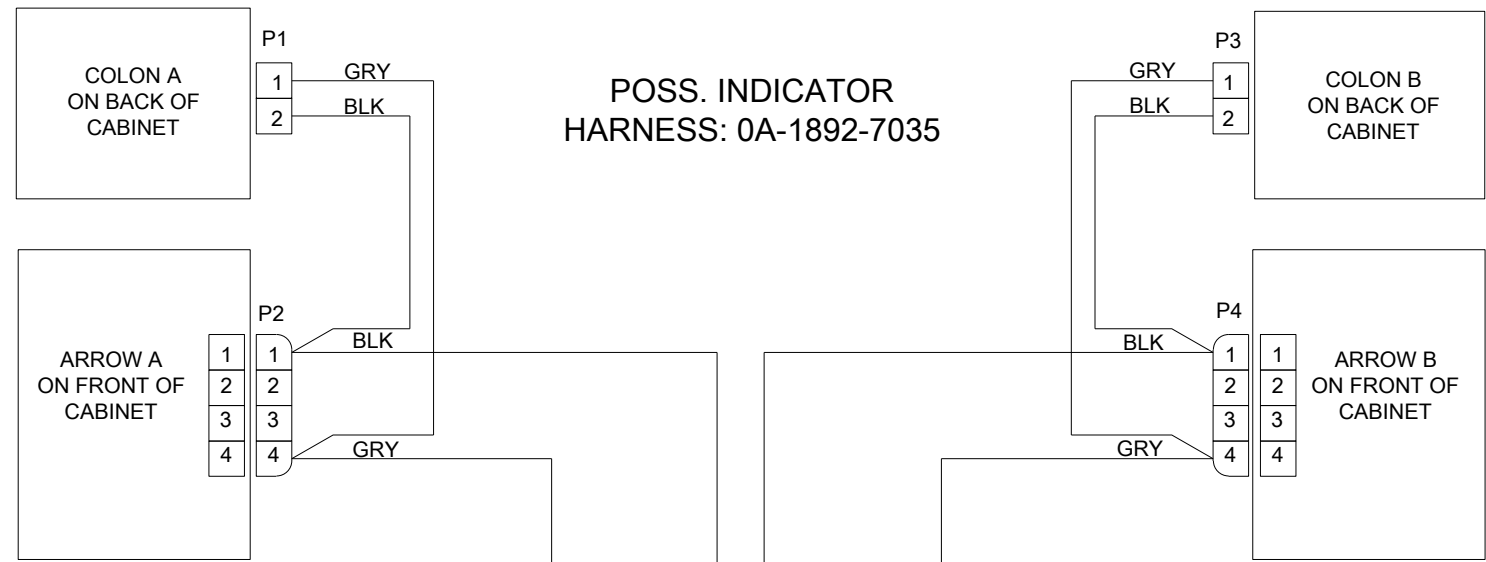

REV 02	DATE: 15 FEB 24	PER CN-173640, UPDATED HARNESSING TO REMOVE EDGE CONNECTORS AND UPDATED MAIN HARNESS PN.	BY: TBS
REV 01	DATE: 09 NOV 16	ADDED ZIP TIE LOCATIONS PER EC-22756	BY: CLT

		<small>THE CONCEPTS EXPRESSED AND DETAILS SHOWN ON THIS DRAWING ARE CONFIDENTIAL AND PROPRIETARY. DO NOT REPRODUCE BY ANY MEANS WITHOUT THE EXPRESS WRITTEN CONSENT OF DAKTRONICS, INC. OR ITS WHOLLY OWNED SUBSIDIARIES. COPYRIGHT 2016 DAKTRONICS, INC. (USA)</small>			
PROJECT: ST-23XX TABLES					
TITLE: SCHEM; TABLE TOP POSS. INDICATOR W/ PWR CORD					
DATE: 6 JUN 16	DIM UNITS: INCHES [MILLIMETERS]		SHEET	REV 02	
SCALE: NONE	DO NOT SCALE DRAWING				
DESIGN: BFOLKER	JOB NO. P1892	FUNC - TYPE - SIZE R - 03 - B		3378521	
DRAWN: BFOLKER					

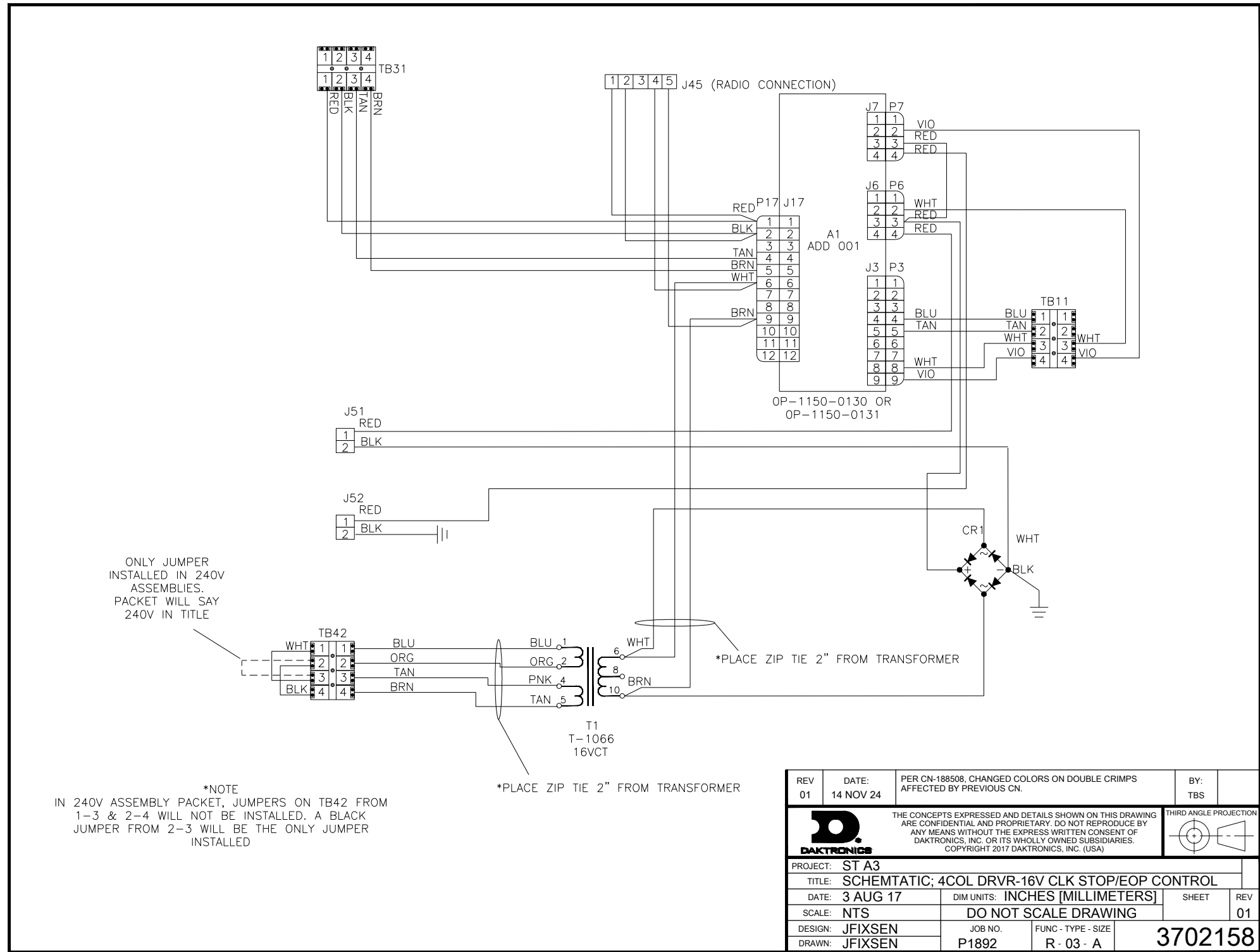

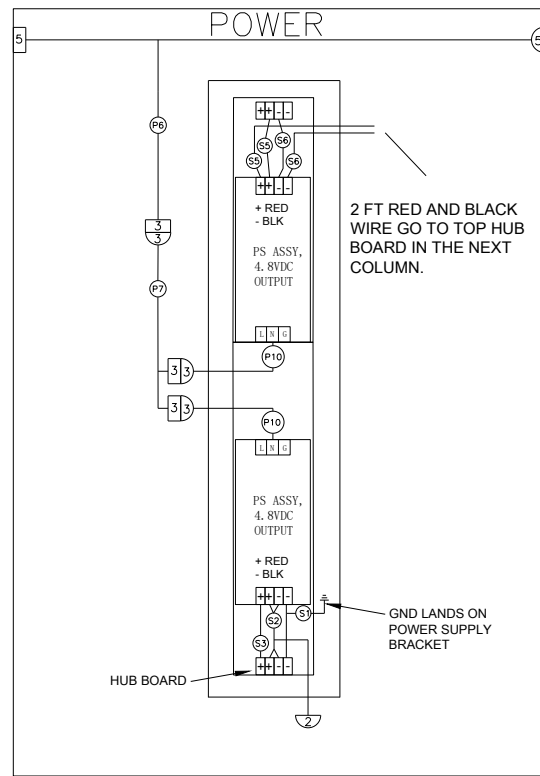

P2307 UHP POWER SUPPLIES 4.8VDC

QTY	PS#	PART #	DESC
1	PS1	0A-2307-7029	ASSY; UHP-350-4.8V PLR PWR SUPPLY
5	PS2, PS3, PS4	0A-2307-7030	ASSY; UHP-350-4.8V LOWER PWR SUPPLY
3	PS5, PS6	0A-2307-7031	ASSY; UHP-350-4.8V TOP PWR SUPPLY

P2307 MUP POWER SUPPLIES 4.8VDC

QTY	PS#	PART #	DESC
1	PS1	0A-2307-7033	ASSY; MUP-260-4.8V PLR PWR SUPPLY
5	PS2, PS3, PS4	0A-2307-7034	ASSY; MUP-260-4.8V LOWER PWR SUPPLY
3	PS5, PS6	0A-2307-7035	ASSY; MUP-260-4.8V TOP PWR SUPPLY

P2432 UHP POWER SUPPLIES 4.6VDC

QTY	PS#	PART #	DESC
1	PS1	0A-2432-7029	ASSY; UHP-350-4.6V PLR PWR SUPPLY
5	PS2, PS3, PS4	0A-2432-7030	ASSY; UHP-350-4.6V LOWER PWR SUPPLY
3	PS5, PS6	0A-2432-7031	ASSY; UHP-350-4.6V TOP PWR SUPPLY

P2432 MUP POWER SUPPLIES 4.6VDC

QTY	PS#	PART #	DESC
1	PS1	0A-2432-7033	ASSY; MUP-260-4.6V PLR PWR SUPPLY
5	PS2, PS3, PS4	0A-2432-7034	ASSY; MUP-260-4.6V LOWER PWR SUPPLY
3	PS5, PS6	0A-2432-7035	ASSY; MUP-4.6V TOP PWR SUPPLY

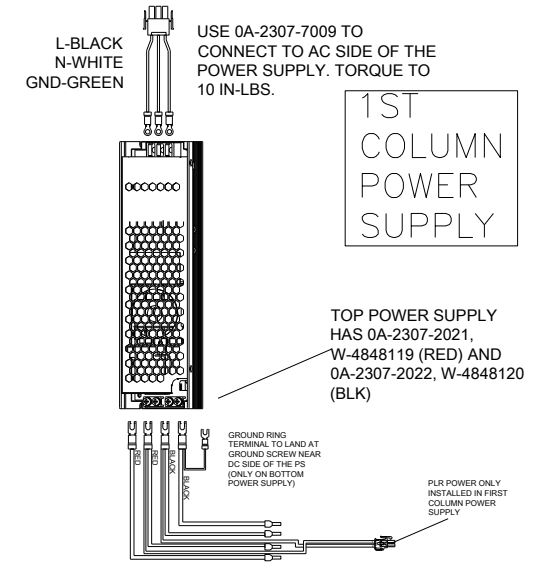
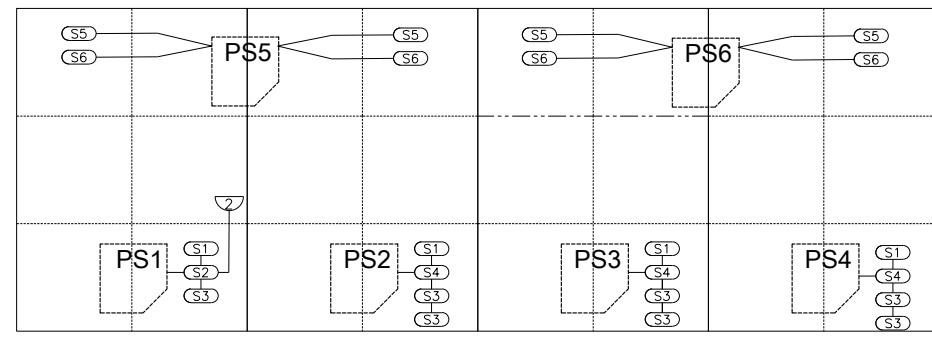

USE 0A-2307-7021 (RED) AND 0A-2307-7019 @1 (RED & BLACK) AND 0A-2307-7020 (BLACK WITH GROUND) TO CONNECT TO BOTTOM HUB CARD. CONNECT CORRESPONDING WIRE TO BLACK/RED TERMINALS ON HUB CARD. TORQUE DC TERMINAL SCREWS TO 10 IN-LBS.

POWER

AC WIRING NOTES
 (COLOR CORRESPONDS TO HARNESS)
 BLACK=N1
 WHITE=N1
 GREEN=G1
 INSERT CORRECT COLOR WIRE INTO ANY AVAILABLE CORRESPONDING OPENING

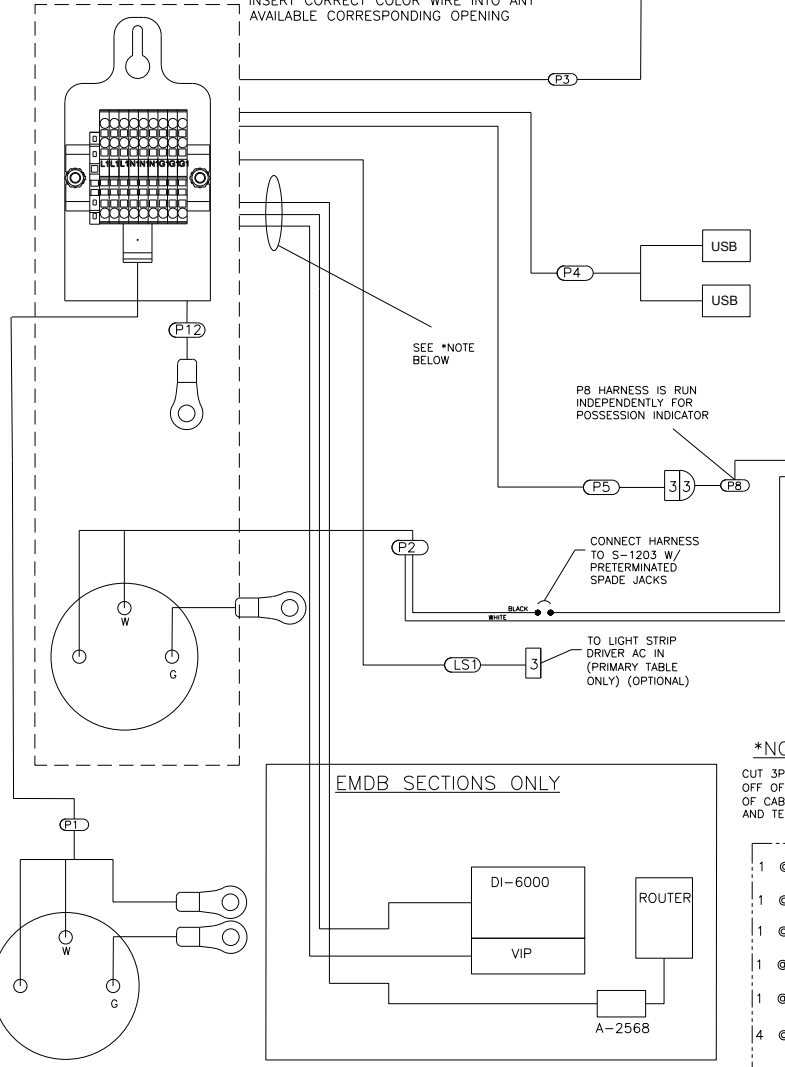

TOP POWER SUPPLIES MOUNT TO REAR BACKSHEET IN-BETWEEN HUB COLUMNS

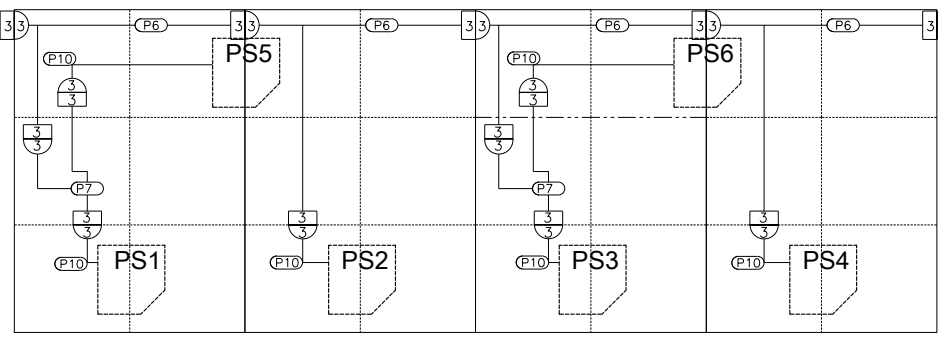

OUTLETS (FRONT VIEW)

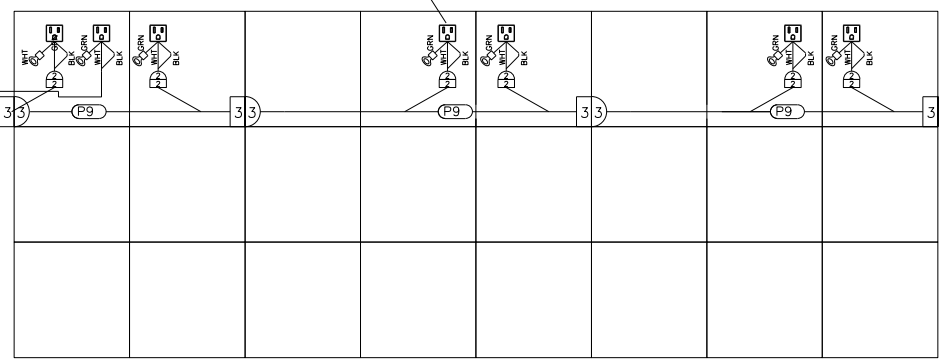

*NOTE
 CUT 3P MALE END OFF OF CABLE. STRIP 3" OF INSULATION OFF OF CABLE, THEN STRIP .25" OFF EACH WIRE AND TERMINATE TO PT PANEL
 2--- MALE 2--- FEMALE 3--- MALE 3--- FEMALE

- 1 @ P1 0A-2307-7006 HARN; POWERCON TOP BARE WIRE, 5IN, 12AWG
- 1 @ P2 0A-2307-7004 HARN; 3F UMNL TO EM UMNL (NO GND) AND QCK DIS
- 1 @ P3 0A-2307-7007 HARN; 3F UMNL TO BARE WIRE, 21IN
- 1 @ P4 0A-1892-7013 HARN; USB OUTLET, ST A3
- 1 @ P5 0A-2307-7008 HARN; 3F UMNL, 12AWG BARE, 30IN
- 4 @ P6 0A-2307-7005 HARN; 3F UMNL, 12AWG, 3F UMNL, 3F UMNL 18AWG
- 2 @ P7 0A-2307-7011 HARN; 3M UMNL TO TWO 3F UMNL, 18AWG, 5IN
- 1 @ P8 0A-1892-7006 HARN; POSSESSION INDICATOR OUTLET 120V
- 3 @ P9 0A-2307-7010 HARN; CONVENIENCE OUTLET INTERCONNECT
- 6 @ P10 0A-2307-7009 HARN; 3M UMNL TO RING, 18AWG, 5IN
- 6 @ P11 0A-1892-7004 HARN; OUTLET W/WHIP, 120V
- 1 @ P12 0A-2307-7039 HARN; RING TO BARE, 19 STR, 12AWG, GRN, 10 IN
- 3 @ P13 0A-2307-7038 HARN; RING TO RING, 19 STR, 12AWG, GRN, 8 IN
- 4 @ S1 0A-2307-7020 HARN; FORK, 12AWG AND FORK 18AWG
- 1 @ S2 0A-2307-7019 HARN; FORK-BARE, 12AWG, 2M MINI UMNL 18AWG
- 7 @ S3 0A-2307-7021 HARN; FORK-BARE 12AWG 65 STR RED 9IN
- 3 @ S4 0A-2307-7022 HARN; FORK-BARE 12AWG 65 STR BLK 9IN
- 4 @ S5 W-4848119 HARN; FORK-BARE 10AWG, 105 STR, RED 2FT
- 4 @ S6 W-4848120 HARN; FORK-BARE 10AWG, 105 STR, BLK 2FT

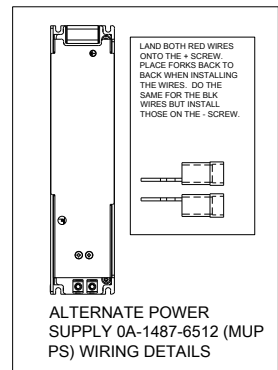

RECEIVER CARD MUST BE INSTALLED ON EACH HUB CARD. ORIENTATION IS SHOWN BELOW WITH THE TWO SMALLER CHIPS ON THE LEFT OF THE CARD WHEN PRESSED DOWN ON TOP OF THE HUB CARD.

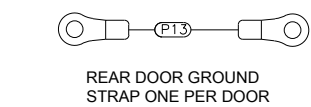
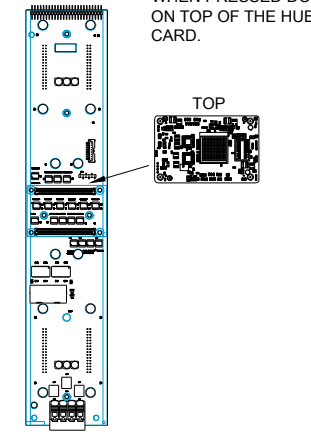

REV	DATE	DESCRIPTION	BY
04	24 JUN 22	CN142652 ADDED MUP-260 POWER SUPPLY OPTION	JSF
03	10 MAY 22	CN138647 ADDED P2432 POWER SUPPLY LIST	JSF
02	25 JAN 22	CN133848 ADDED GROUND STRAP TO POWER IN TERM BLOCK AND TO EACH REAR DOOR	JSF
01	02 SEPT 21	CN128606 REMOVED POWER STRIP FOR EMBEDDED CONTROL. CHANGED PLACEMENT OF TOP POWER SUPPLIES	JSF

PROJECT: ST-B1
 TITLE: BLOCK DIAGRAM ST-B1 3X8
 DATE: 07 JUN 21 DIM UNITS: INCHES (MILLIMETERS) SHEET: 04
 SCALE: NTS DO NOT SCALE DRAWING
 DESIGN: JFIXSEN JOB NO: P2307
 DRAWN: JFIXSEN P2307 R-01-C 4797965

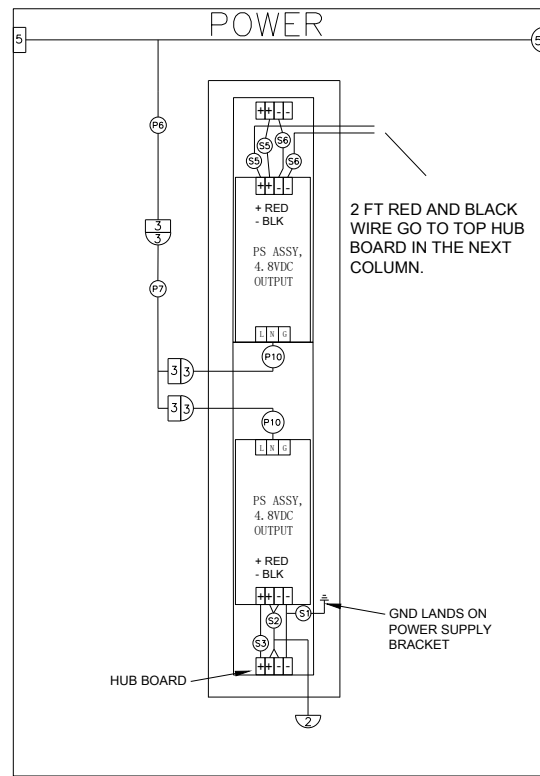

P2307 UHP POWER SUPPLIES 4.8VDC

QTY	PS#	PART #	DESC
1	PS1	0A-2307-7029	ASSY; UHP-350-4.8V PLR PWR SUPPLY
4	PS2, PS3, PS4, PS5	0A-2307-7030	ASSY; UHP-350-4.8V LOWER PWR SUPPLY
2	PS6, PS8	0A-2307-7031	ASSY; UHP-350-4.8V TOP PWR SUPPLY
1	PS7	0A-2307-7032	ASSY; UHP-350-4.8V TOP PWR W/O 2FT WIRES

P2432 UHP POWER SUPPLIES 4.6VDC

QTY	PS#	PART #	DESC
1	PS1	0A-2432-7029	ASSY; UHP-350-4.6V PLR PWR SUPPLY
4	PS2, PS3, PS4, PS5	0A-2432-7030	ASSY; UHP-350-4.6V LOWER PWR SUPPLY
2	PS6, PS8	0A-2432-7031	ASSY; UHP-350-4.6V TOP PWR SUPPLY
1	PS7	0A-2432-7032	ASSY; UHP-350-4.6V TOP PWR W/O 2FT WIRES

P2307 MUP POWER SUPPLIES 4.8VDC

QTY	PS#	PART #	DESC
1	PS1	0A-2307-7033	ASSY; MUP-260-4.8V PLR PWR SUPPLY
4	PS2, PS3, PS4, PS5	0A-2307-7034	ASSY; MUP-260-4.8V LOWER PWR SUPPLY
2	PS6, PS8	0A-2307-7035	ASSY; MUP-260-4.8V TOP PWR SUPPLY
1	PS7	0A-2307-7036	ASSY; MUP-260-4.8V TOP PWR W/O 2FT WIRES

P2432 MUP POWER SUPPLIES 4.6VDC

QTY	PS#	PART #	DESC
1	PS1	0A-2432-7033	ASSY; MUP-260-4.6V PLR PWR SUPPLY
4	PS2, PS3, PS4, PS5	0A-2432-7034	ASSY; MUP-260-4.6V LOWER PWR SUPPLY
2	PS6, PS8	0A-2432-7035	ASSY; MUP-260-4.6V TOP PWR SUPPLY
1	PS7	0A-2432-7035	ASSY; MUP-260-4.6V TOP PWR W/O 2FT WIRES

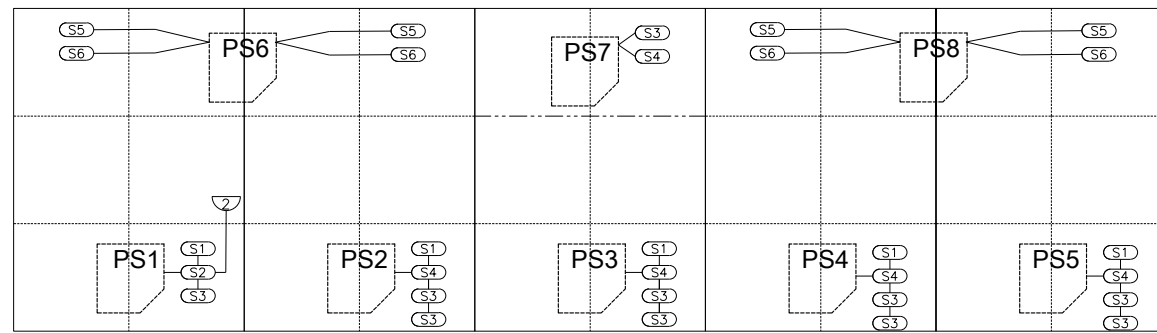

TOP POWER SUPPLIES MOUNT TO REAR BACKSHEET IN-BETWEEN HUB COLUMNS PS7 MOUNTS IN HUB COLUMN

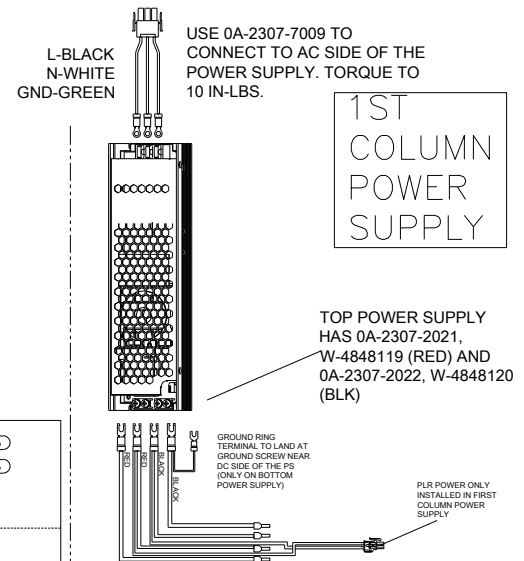

USE 0A-2307-7021 (RED) AND 0A-2307-7019 @1 (RED & BLACK) AND 0A-2307-7020 (BLACK WITH GROUND) TO CONNECT TO BOTTOM HUB CARD. CONNECT CORRESPONDING WIRE TO BLACK/RED TERMINALS ON HUB CARD. TORQUE DC TERMINAL SCREWS TO 10 IN.-LBS.

RECEIVER CARD MUST BE INSTALLED ON EACH HUB CARD. ORIENTATION IS SHOWN BELOW WITH THE TWO SMALLER CHIPS ON THE LEFT OF THE CARD WHEN PRESSED DOWN ON TOP OF THE HUB CARD.

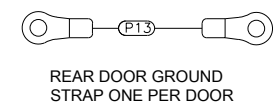
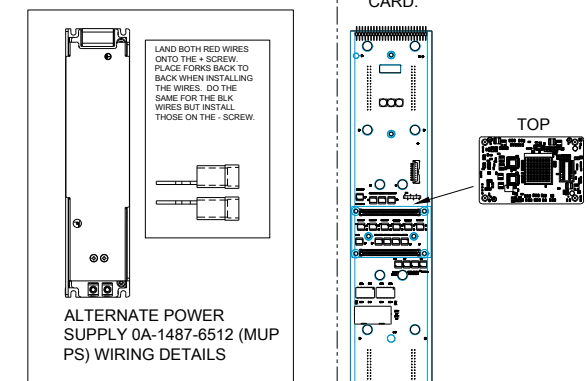

POWER

AC WIRING NOTES
(COLOR CORRESPONDS TO HARNESS)
BLACK=L1
WHITE=N1
GREEN=G1
INSERT CORRECT COLOR WIRE INTO ANY AVAILABLE CORRESPONDING OPENING

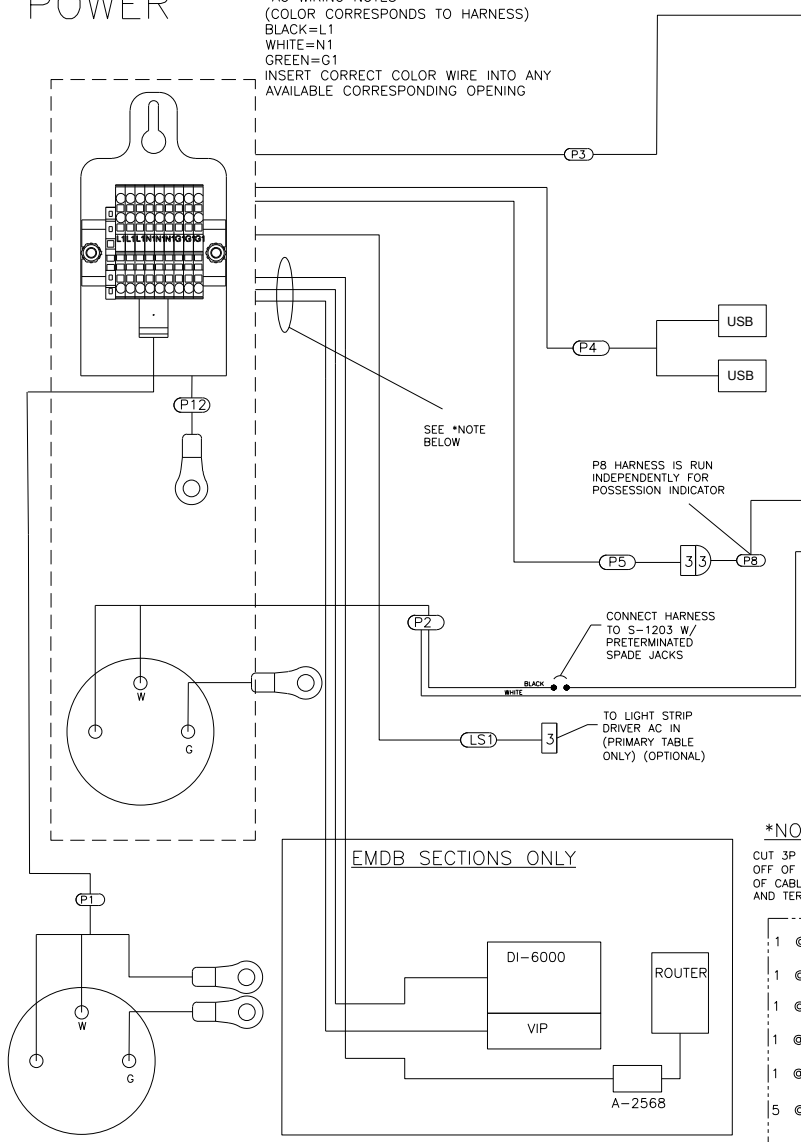

OUTLETS (FRONT VIEW)

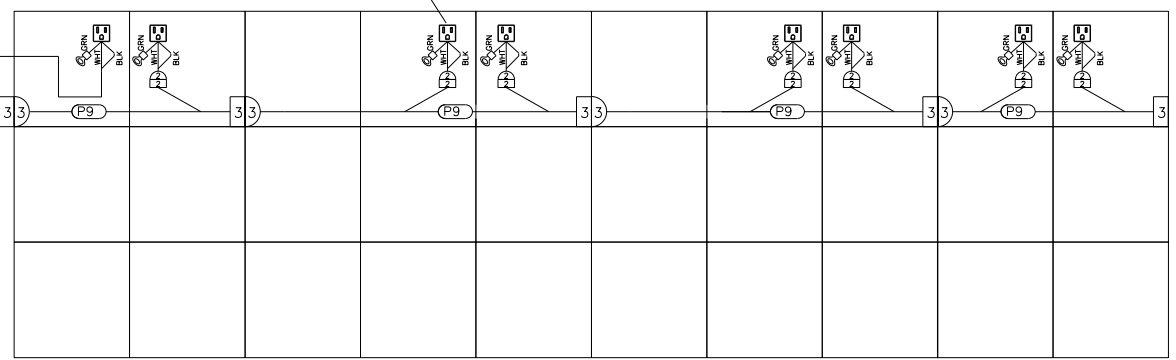

*NOTE
CUT 3P MALE END OFF OF CABLE. STRIP 3" OF INSULATION OFF OF CABLE, THEN STRIP .25" OFF EACH WIRE AND TERMINATE TO P1 PANEL

②--- MALE ②--- FEMALE ③--- MALE ③--- FEMALE

- 1 @ P1 0A-2307-7006 HARN; POWERCON TOP BARE WIRE, 5IN, 12AWG
- 1 @ P2 0A-2307-7004 HARN; 3F UMNL TO EM UMNL (NO GND) AND OCK DIS
- 1 @ P3 0A-2307-7007 HARN; 3F UMNL TO BARE WIRE, 21IN
- 1 @ P4 0A-1892-7013 HARN; USB OUTLET, ST A3
- 1 @ P5 0A-2307-7008 HARN; 3F UMNL, 12AWG BARE, 30IN
- 5 @ P6 0A-2307-7005 HARN; 3F UMNL, 12AWG, 3F UMNL, 3F UMNL 18AWG
- 3 @ P7 0A-2307-7011 HARN; 3M UMNL TO TWO 3F UMNL, 18AWG, 5IN
- 1 @ P8 0A-1892-7006 HARN; POSSESSION INDICATOR OUTLET 120V
- 4 @ P9 0A-2307-7010 HARN; CONVENIENCE OUTLET INTERCONNECT
- 8 @ P10 0A-2307-7009 HARN; 3M UMNL TO RING, 18AWG 5IN
- 8 @ P11 0A-1892-7004 HARN; OUTLET W/WHIP, 120V
- 1 @ P12 0A-2307-7039 HARN; RING TO BARE, 19 STR, 12AWG, GRN, 10 IN
- 4 @ P13 0A-2307-7038 HARN; RING TO RING, 19 STR, 12AWG, GRN, 8 IN
- 5 @ S1 0A-2307-7020 HARN; FORK, 12AWG AND FORK 18AWG
- 1 @ S2 0A-2307-7019 HARN; FORK-BARE, 12AWG, 2M MINI UMNL 18AWG
- 10 @ S3 0A-2307-7021 HARN; FORK-BARE 12AWG 65 STR RED 9IN
- 5 @ S4 0A-2307-7022 HARN; FORK-BARE 12AWG 65 STR BLK 9IN
- 4 @ S5 W-4848119 HARN; FORK-BARE 10AWG, 105 STR, RED 2FT
- 4 @ S6 W-4848120 HARN; FORK-BARE 10AWG, 105 STR, BLK 2FT

INCLUDED IN POWER SUPPLIES LISTED ABOVE

REV	DATE	DESCRIPTION	BY
04	24 JUN 22	CN142652 ADDED MUP-260 POWER SUPPLY OPTION	JSF
03	10 MAY 22	CN138647 ADDED P2432 POWER SUPPLY LIST	JSF
02	25 JAN 22	CN133848 ADDED GROUND STRAP TO POWER IN TERM BLOCK AND TO EACH REAR DOOR	JSF
01	02 SEPT 21	CN128606 REMOVED POWER STRIP FOR EMBEDDED CONTROL. CHANGED PLACEMENT OF TOP POWER SUPPLIES	JSF

PROJECT: ST-B1
TITLE: BLOCK DIAGRAM ST-B1 3X10
DATE: 07 JUN 21
SCALE: NTS
DESIGN: JFIXSEN
DRAWN: JFIXSEN

DM UNITS: INCHES (MILLIMETERS)
DO NOT SCALE DRAWING
JOB NO: P2307
FUNC: TYPE-SIZE
F-01-C

SHEET 04
REV 04
4797966

POWER

RECEIVER CARD MUST BE INSTALLED ON EACH HUB CARD. ORIENTATION IS SHOWN BELOW WITH THE TWO SMALLER CHIPS ON THE LEFT OF THE CARD WHEN PRESSED DOWN ON TOP OF THE HUB CARD.

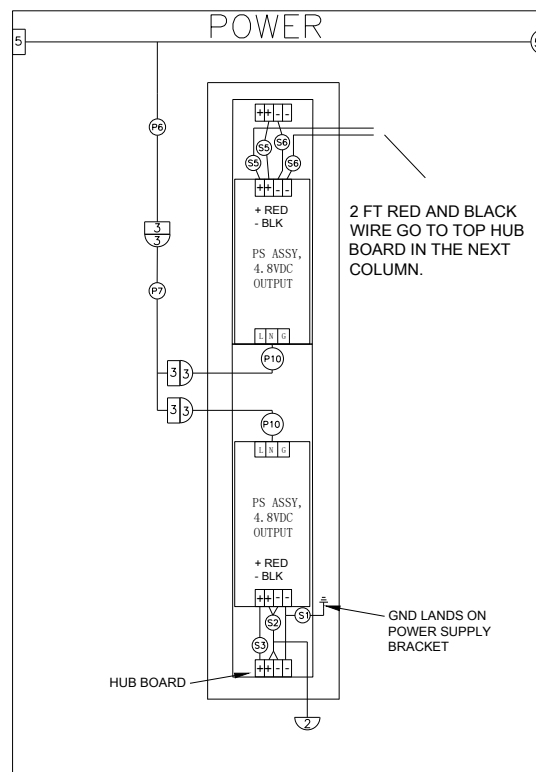
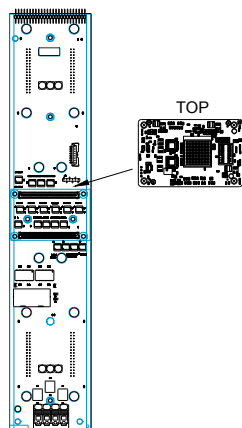

P2307 UHP POWER SUPPLIES 4.8VDC			
QTY	PS#	PART #	DESC
1	PS1	0A-2307-7029	ASSY; UHP-350-4.8V PLR PWR SUPPLY
5	PS2, PS3, PS4, PS5, PS6	0A-2307-7030	ASSY; UHP-350-4.8V LOWER PWR SUPPLY
3	PS7, PS8, PS9	0A-2307-7031	ASSY; UHP-350-4.8V TOP PWR SUPPLY

P2432 UHP POWER SUPPLIES 4.6VDC			
QTY	PS#	PART #	DESC
1	PS1	0A-2432-7029	ASSY; UHP-350-4.6V PLR PWR SUPPLY
5	PS2, PS3, PS4, PS5, PS6	0A-2432-7030	ASSY; UHP-350-4.6V LOWER PWR SUPPLY
3	PS7, PS8, PS9	0A-2432-7031	ASSY; UHP-350-4.6V TOP PWR SUPPLY

P2307 MUP POWER SUPPLIES 4.8VDC			
QTY	PS#	PART #	DESC
1	PS1	0A-2307-7033	ASSY; MUP-260-4.8V PLR PWR SUPPLY
5	PS2, PS3, PS4, PS5, PS6	0A-2307-7034	ASSY; MUP-260-4.8V LOWER PWR SUPPLY
3	PS7, PS8, PS9	0A-2307-7035	ASSY; MUP-260-4.8V TOP PWR SUPPLY

P2432 MUP POWER SUPPLIES 4.6VDC			
QTY	PS#	PART #	DESC
1	PS1	0A-2432-7033	ASSY; MUP-260-4.6V PLR PWR SUPPLY
5	PS2, PS3, PS4, PS5, PS6	0A-2432-7034	ASSY; MUP-260-4.6V LOWER PWR SUPPLY
3	PS7, PS8, PS9	0A-2432-7035	ASSY; MUP-4.6V TOP PWR SUPPLY

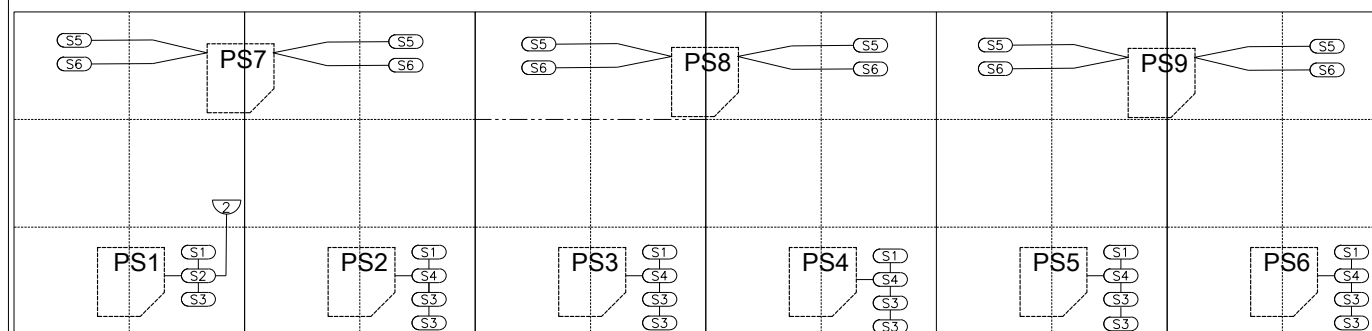
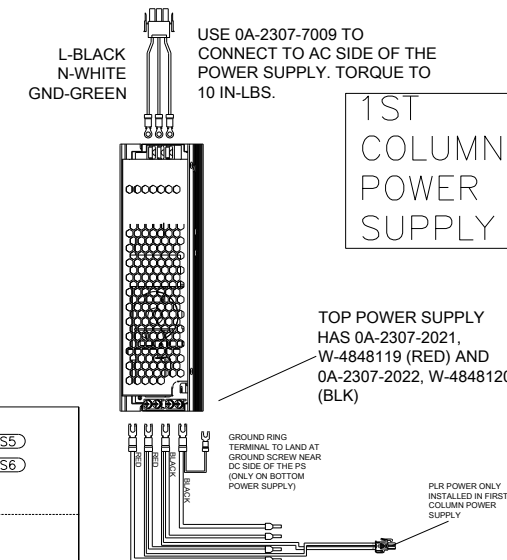

TOP POWER SUPPLIES MOUNT TO REAR BACKSHEET IN-BETWEEN HUB COLUMNS

USE 0A-2307-7021 (RED) AND 0A-2307-7019 @1 (RED & BLACK) AND 0A-2307-7020 (BLACK WITH GROUND) TO CONNECT TO BOTTOM HUB CARD. CONNECT CORRESPONDING WIRE TO BLACK/RED TERMINALS ON HUB CARD. TORQUE DC TERMINAL SCREWS TO 10 IN-LBS.

POWER

AC WIRING NOTES
 (COLOR CORRESPONDS TO HARNESS)
 BLACK=L1
 WHITE=N1
 GREEN=G1
 INSERT CORRECT COLOR WIRE INTO ANY AVAILABLE CORRESPONDING OPENING

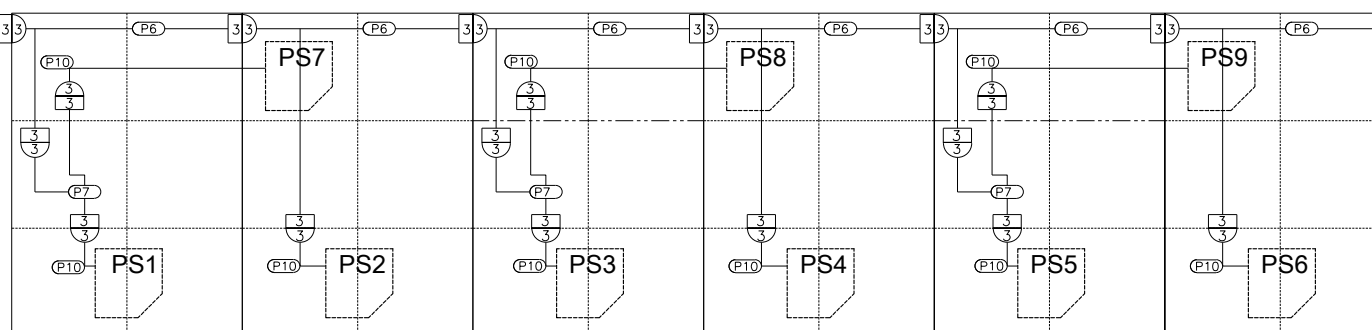
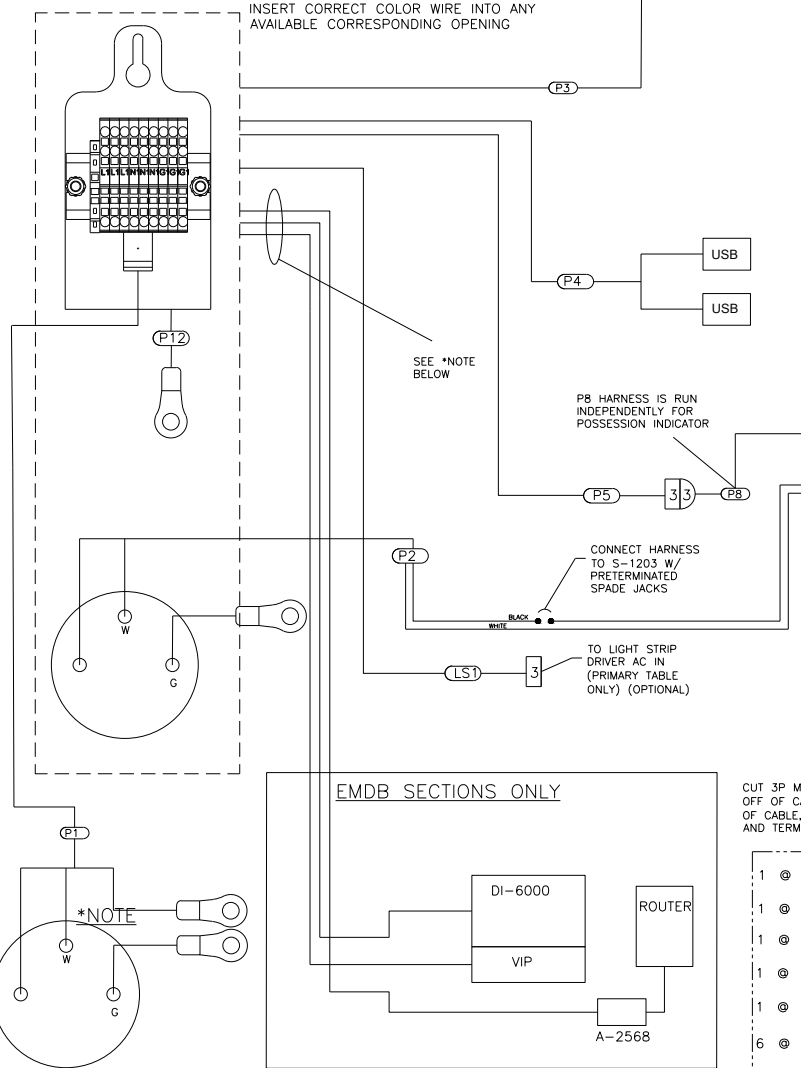

OUTLETS (FRONT VIEW)

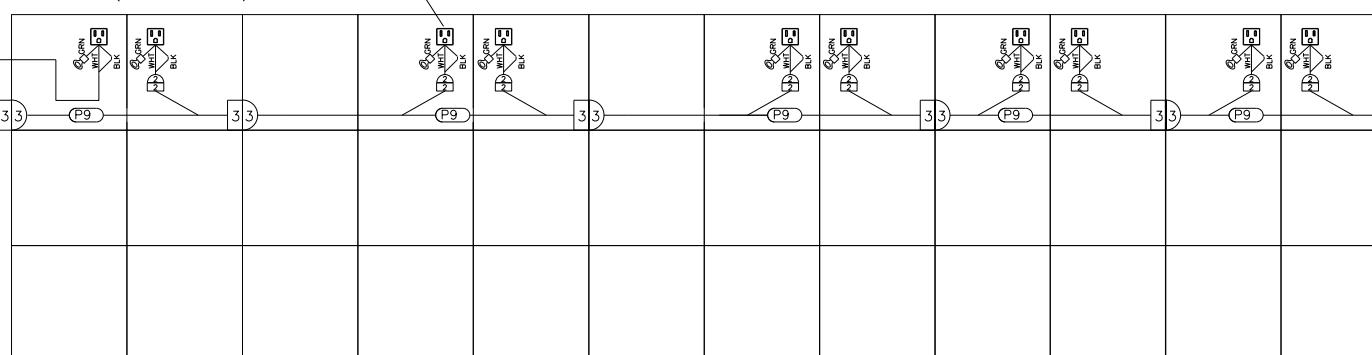

CUT 3P MALE END OFF OF CABLE. STRIP 3" OF INSULATION OFF OF CABLE, THEN STRIP .25" OFF EACH WIRE AND TERMINATE TO PT PANEL

--- MALE
 --- FEMALE
 --- MALE
 --- FEMALE

- | | | | | | |
|--------|---|----------|---|---------|---|
| 1 @ P1 | 0A-2307-7006
HARN; POWERCON TOP BARE WIRE, 5IN, 12AWG | 3 @ P7 | 0A-2307-7011
HARN; 3M UMNLR TO TWO 3F UMNLR, 18AWG, 5IN; | 6 @ S1 | 0A-2307-7020
HARN; FORK, 12AWG AND FORK 18AWG |
| 1 @ P2 | 0A-2307-7004
HARN; 3F UMNLR TO EM UMNLR (NO GND) AND QCK DIS | 1 @ P8 | 0A-1892-7006
HARN; POSSESSION INDICATOR OUTLET 120V | 1 @ S2 | 0A-2307-7019
HARN; FORK-BARE, 12AWG, 2M MINI UMNLR 18AWG |
| 1 @ P3 | 0A-2307-7007
HARN; 3F UMNLR TO BARE WIRE, 21IN | 5 @ P9 | 0A-2307-7010
HARN; CONVENIENCE OUTLET INTERCONNECT | 11 @ S3 | 0A-2307-7021
HARN; FORK-BARE 12AWG 65 STR RED 9IN |
| 1 @ P4 | 0A-1892-7013
HARN; 3F UMNLR TO BARE WIRE, 21IN | 9 @ P10 | 0A-2307-7009
HARN; 3M UMNLR TO RING, 18AWG, 5IN | 5 @ S4 | 0A-2307-7022
HARN; FORK-BARE 12AWG 65 STR BLK 9IN |
| 1 @ P5 | 0A-2307-7008
HARN; 3F UMNLR, 12AWG BARE, 30IN | 10 @ P11 | 0A-1892-7004
HARN; OUTLET W/WHIP, 120V | 6 @ S5 | W-4848119
HARN; FORK-BARE 10AWG, 105 STR, RED 2FT |
| 1 @ P6 | 0A-2307-7005
HARN; 3F UMNLR, 12AWG, 3F UMNLR 18AWG | 1 @ P12 | 0A-2307-7039
HARN; RING TO BARE, 19 STR, 12AWG, GRN, 10 IN | 6 @ S6 | W-4848120
HARN; FORK-BARE 10AWG, 105 STR, BLK 2FT |
| | | 5 @ P13 | 0A-2307-7038
HARN; RING TO RING, 19 STR, 12AWG, GRN, 8 IN | | |
- ***INCLUDED IN POWER SUPPLIES LISTED ABOVE***

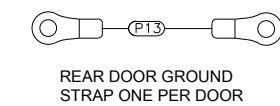
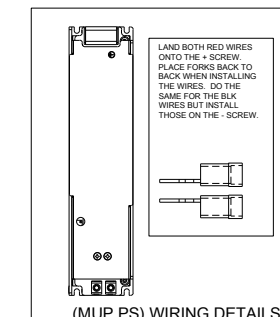

REV	DATE	DESCRIPTION	BY
04	24 JUN 22	CN142652 ADDED MUP-260 POWER SUPPLY OPTION	JSF
03	10 MAY 22	CN139647 ADDED P2432 POWER SUPPLY LIST	JSF
02	25 JAN 22	CN133848 ADDED GROUND STRAP TO POWER IN TERM BLOCK AND TO EACH REAR DOOR	JSF
01	02 SEPT 21	CN126606 REMOVED POWER STRIP FOR EMBEDDED CONTROL. CHANGED PLACEMENT OF TOP POWER SUPPLIES	JSF

PROJECT: ST-B1
 TITLE: BLOCK DIAGRAM ST-B1 3X12
 DATE: 07 JUN 21 DIM UNITS: INCHES (MILLIMETERS) SHEET: 04
 SCALE: NTS DO NOT SCALE DRAWING
 DESIGN: JFIXSEN JOB NO: P2307 FUNC: TYPE-SIZE 4797967
 DRAWN: JFIXSEN

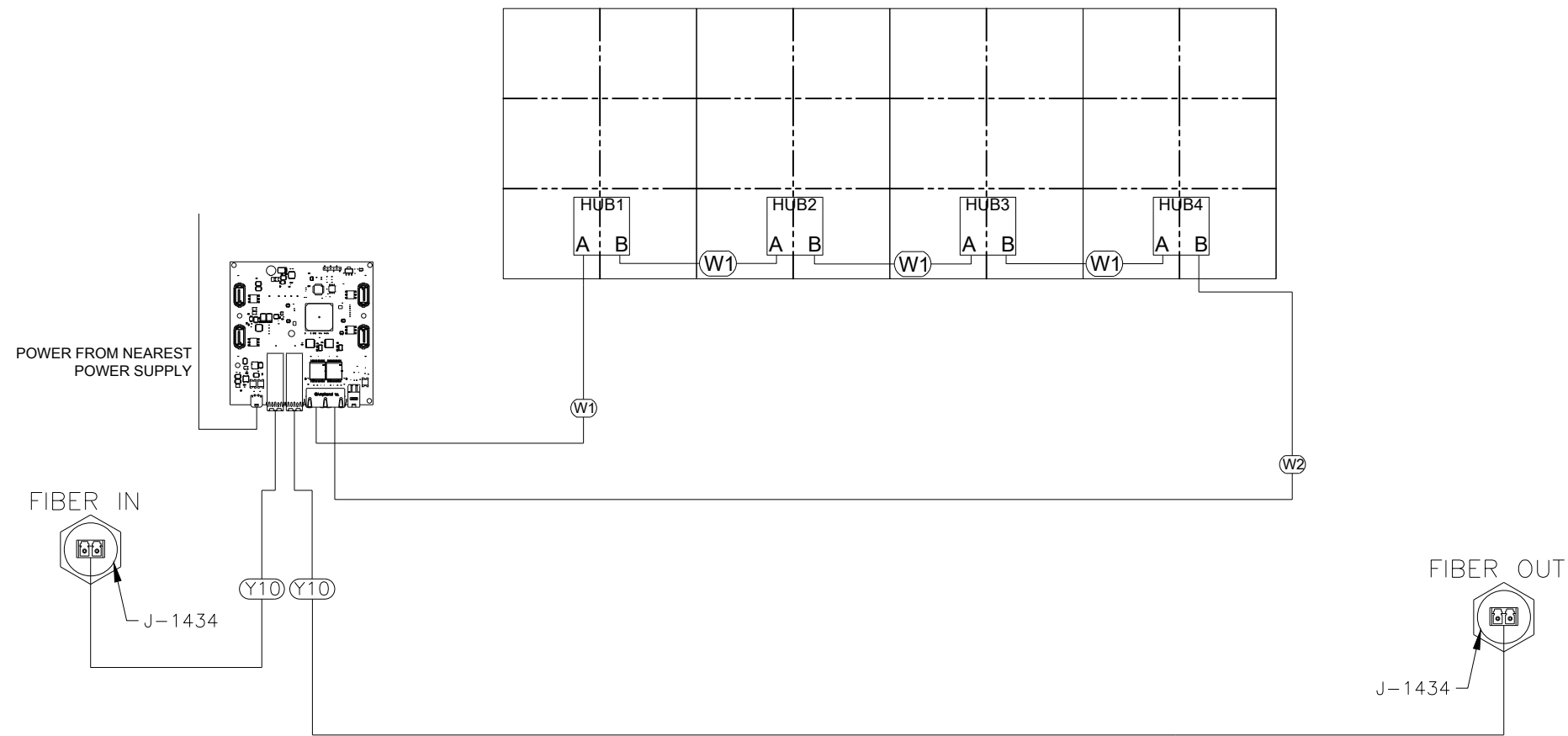

HARNES LEGEND

4	⊙	W1	W-4601395 CABLE ASSY, RJ45, CAT6 SHEILDED, BLK 3FT
1	⊙	W2	W-4212568 CABLE ASSY, RJ45, CAT6 SHEILDED, BLK 10FT
2	⊙	Y10	W-2123 FIBER; 5M 50UM LC-LC DUPLEX, CROSSOVER MM 10G
2	⊙	J-1434	J-1434 JACK; DUPLEX LC FIBER BULKHEAD, FEMALE, INDUSTRIAL

DAKTRONICS		THE CONCEPTS EXPRESSED AND DETAILS SHOWN ON THIS DRAWING ARE CONFIDENTIAL AND PROPRIETARY. DO NOT REPRODUCE BY ANY MEANS WITHOUT THE EXPRESS WRITTEN CONSENT OF DAKTRONICS, INC. OR ITS WHOLLY OWNED SUBSIDIARIES. COPYRIGHT 2021 DAKTRONICS, INC. (USA)		THIRD ANGLE PROJECTION
PROJECT: ST-B1				
TITLE: BLOCK DIAGRAM SIGNAL; ST-B1 3X8				
DATE: 25 JAN 21	DIM UNITS: INCHES [MILLIMETERS]		SHEET	REV
SCALE: NTS	DO NOT SCALE DRAWING			00
DESIGN: JFIXSEN	JOB NO.	FUNC - TYPE - SIZE	4804220	
DRAWN: JFIXSEN	P2307	F - 03 - B		

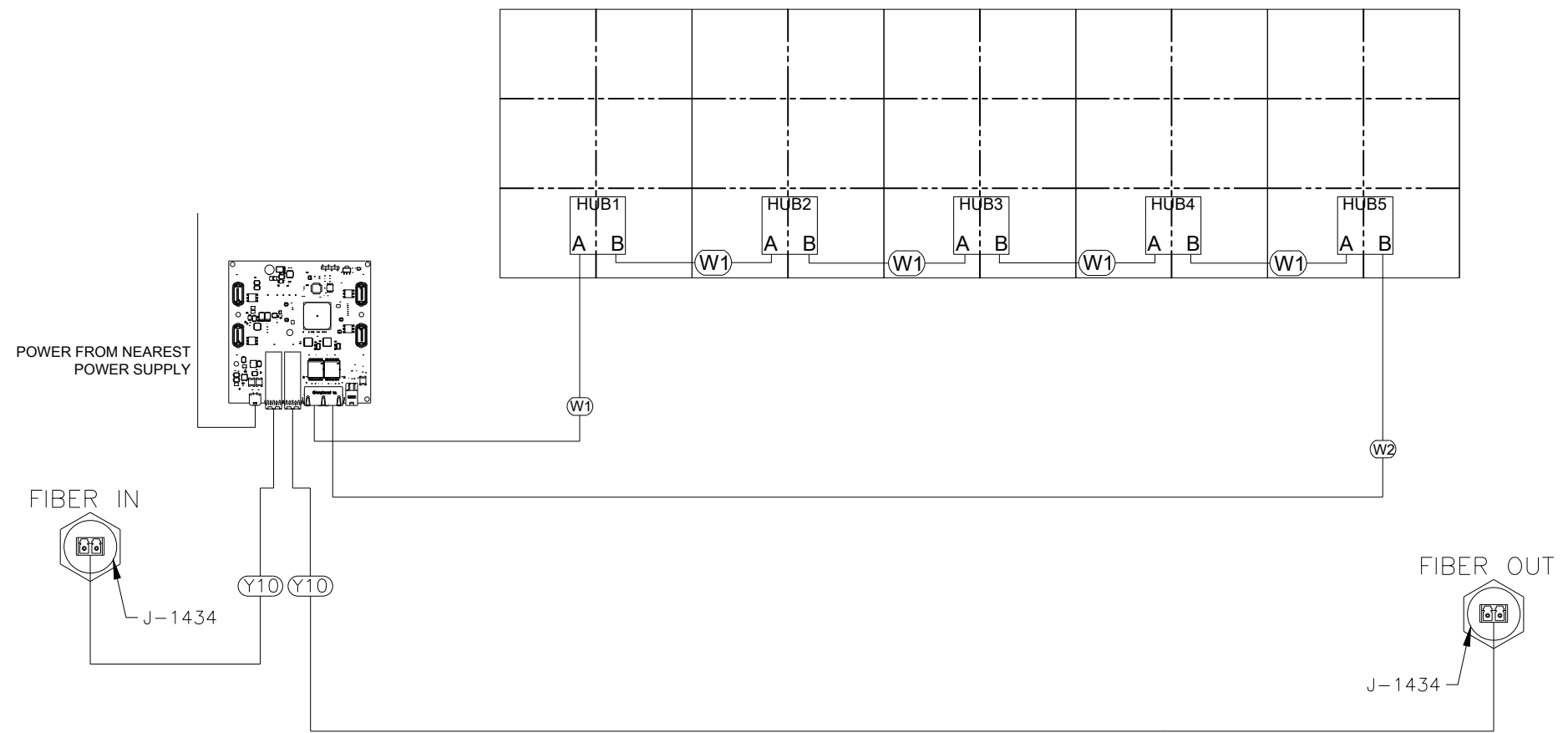

HARNES LEGEND

5	@	W1	W-4601395 CABLE ASSY, RJ45, CAT6 SHEILDED, BLK 3FT
1	@	W2	W-4212568 CABLE ASSY, RJ45, CAT6 SHEILDED, BLK 10FT
2	@	Y10	W-2123 FIBER; 5M 50UM LC-LC DUPLEX, CROSSOVER MM 10G
2	@	J-1434	J-1434 JACK; DUPLEX LC FIBER BULKHEAD, FEMALE, INDUSTRIAL

DAKTRONICS		THE CONCEPTS EXPRESSED AND DETAILS SHOWN ON THIS DRAWING ARE CONFIDENTIAL AND PROPRIETARY. DO NOT REPRODUCE BY ANY MEANS WITHOUT THE EXPRESS WRITTEN CONSENT OF DAKTRONICS, INC. OR ITS WHOLLY OWNED SUBSIDIARIES. COPYRIGHT 2021 DAKTRONICS, INC. (USA)		THIRD ANGLE PROJECTION
PROJECT: ST-B1				
TITLE: BLOCK DIAGRAM SIGNAL; ST-B1 3X10				
DATE: 25 JAN 21	DIM UNITS: INCHES [MILLIMETERS]		SHEET	REV
SCALE: NTS	DO NOT SCALE DRAWING			00
DESIGN: JFIXSEN	JOB NO. P2307	FUNC - TYPE - SIZE	4804221	
DRAWN: JFIXSEN		F - 03 - B		

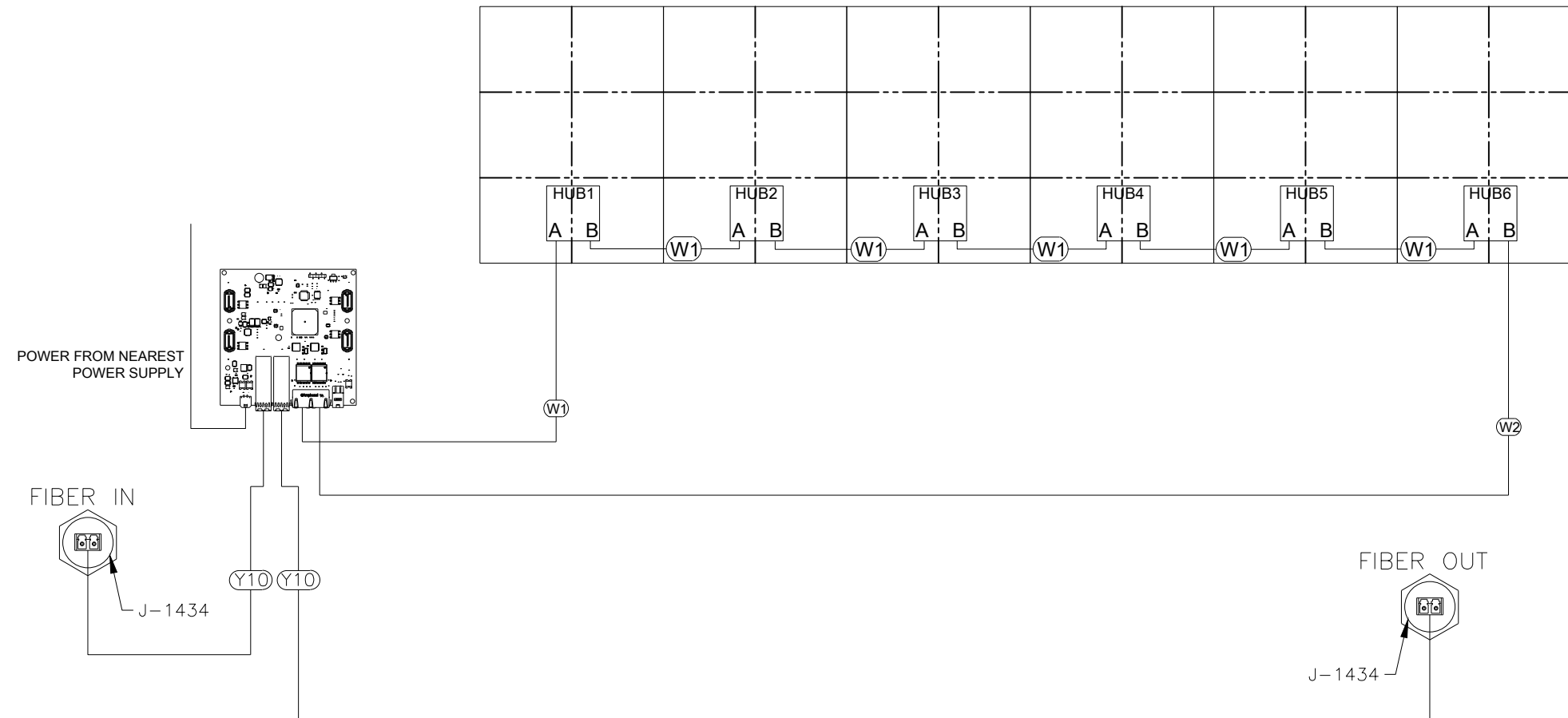

HARNES LEGEND

6	⊙	W1	W-4601395 CABLE ASSY, RJ45, CAT6 SHEILDED, BLK 3FT
1	⊙	W2	W-4212568 CABLE ASSY, RJ45, CAT6 SHEILDED, BLK 10FT
2	⊙	Y10	W-2123 FIBER; 5M 50UM LC-LC DUPLEX, CROSSOVER MM 10G
2	⊙	J-1434	J-1434 JACK; DUPLEX LC FIBER BULKHEAD, FEMALE, INDUSTRIAL

DAKTRONICS		THE CONCEPTS EXPRESSED AND DETAILS SHOWN ON THIS DRAWING ARE CONFIDENTIAL AND PROPRIETARY. DO NOT REPRODUCE BY ANY MEANS WITHOUT THE EXPRESS WRITTEN CONSENT OF DAKTRONICS, INC. OR ITS WHOLLY OWNED SUBSIDIARIES. COPYRIGHT 2021 DAKTRONICS, INC. (USA)		THIRD ANGLE PROJECTION
PROJECT: ST-B1				
TITLE: BLOCK DIAGRAM SIGNAL; ST-B1 3X12				
DATE: 25 JAN 21	DIM UNITS: INCHES [MILLIMETERS]	SHEET	REV	
SCALE: NTS	DO NOT SCALE DRAWING		00	
DESIGN: JFIXSEN	JOB NO. P2307	FUNC - TYPE - SIZE	4804222	
DRAWN: JFIXSEN		F - 03 - B		

EMDB SECTIONS ONLY

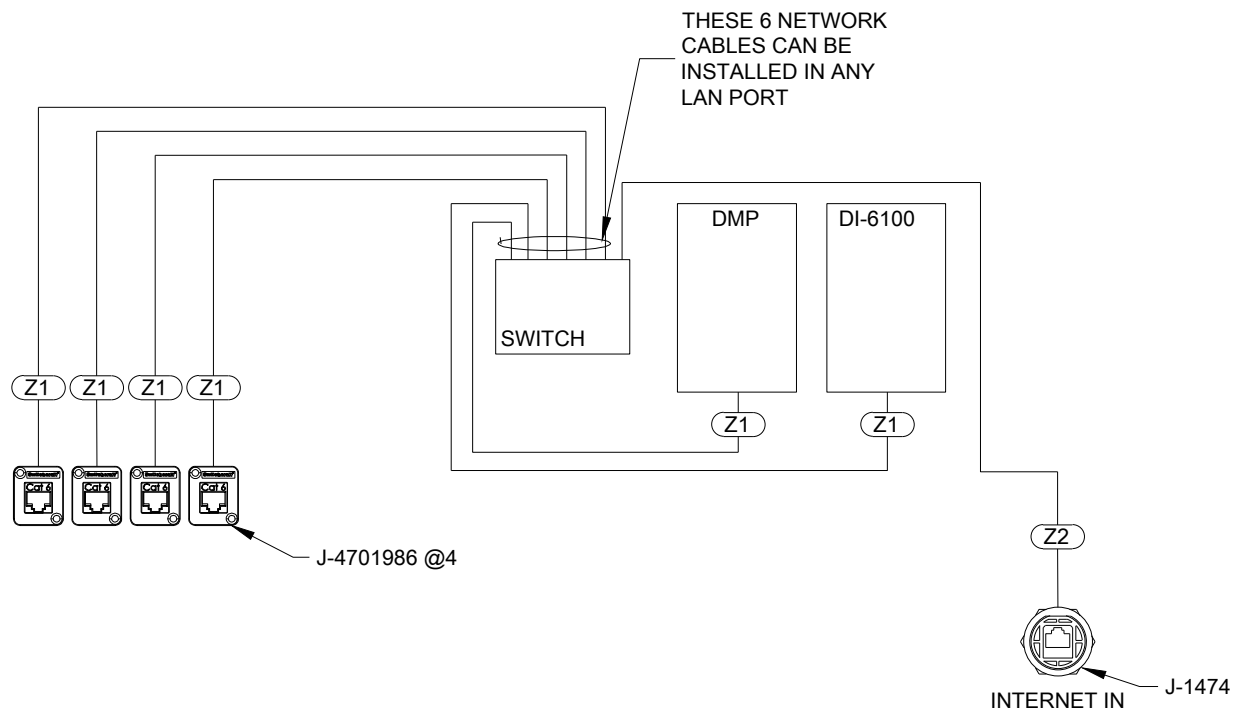

REAR VIEW

- 6 @ Z1 W-1732 CABLE; CAT 5E BLACK RJ45-RJ45; 42"; 4 PAIR
- 1 @ Z2 W-1733 CABLE; CAT 5E BLACK RJ45-RJ45; 84" 4 PAIR
- 4 @ J-4701986 JACK; 8 PIN FEM, RJ45, PANEL MOUNT COUPLER
- 1 @ J-1474 JACK; 8 PIN FEM, RJ45, PANEL MOUNT ODVA, IP67

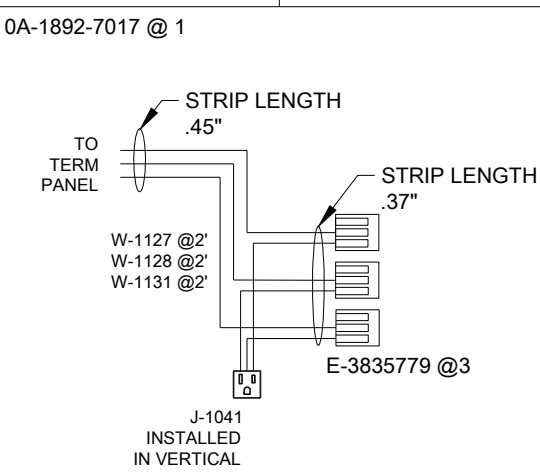
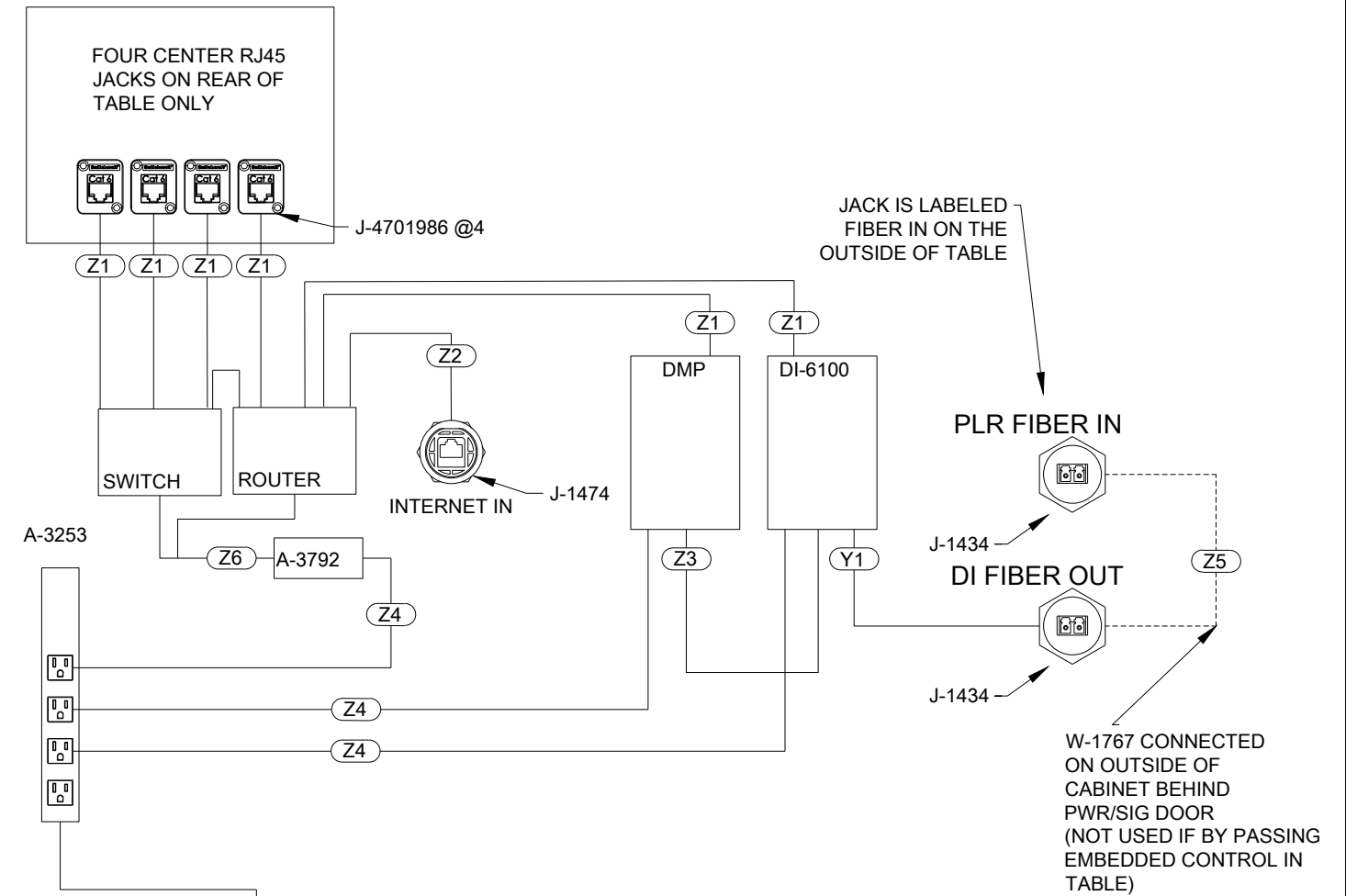

- 1 @ Z2 W-1733 CABLE; CAT 5E BLACK RJ45-RJ45; 84" 4 PAIR
- 1 @ Z3 W-4845477 CABLE; DP(M) TO DP(M), 1M, HBR, LATCH, DISPLAYPORT
- 3 @ Z4 W-1633 POWER CORD; 5' N5-15 TO IEC C13
- 1 @ Z5 W-1767 CABLE; 3FT FIBER OPTIC, INDUSTRIAL LC-LC DUPLEX
- 1 @ Z6 W-5101637 DC SPLITTER CABLE, 2.1MM BARREL JACK TO (2) PLUGS
- 1 @ Y1 W-2123 FIBER; 5M 50UM LC-LC DUPLEX, CROSSOVER MM 10G
- 2 @ J-1434 CABLE; 3FT FIBER OPTIC, INDUSTRIAL LC-LC DUPLEX
- 4 @ J-4701986 JACK; 8 PIN FEM, RJ45, PANEL MOUNT COUPLER
- 1 @ J-1474 JACK; 8 PIN FEM, RJ45, PANEL MOUNT ODVA, IP67

REV 01	DATE: 01 JUL 22	CCN142961 ADDED SWITCH AND Y HARNESS FOR SWITCH AND ROUTER POWER	BY: JSF
		THE CONCEPTS EXPRESSED AND DETAILS SHOWN ON THIS DRAWING ARE CONFIDENTIAL AND PROPRIETARY. DO NOT REPRODUCE BY ANY MEANS WITHOUT THE EXPRESS WRITTEN CONSENT OF DAKTRONICS, INC. OR ITS WHOLLY OWNED SUBSIDIARIES. COPYRIGHT 2021 DAKTRONICS, INC. (USA)	
PROJECT: ST-B1			
TITLE: BLOCK DIAGRAMM; CONTROL, ST-B1			
DATE: 26 JAN 21	DIM UNITS: INCHES [MILLIMETERS]	SHEET	REV 01
SCALE: NTS	DO NOT SCALE DRAWING		
DESIGN: JFIXSEN	JOB NO. P2307	FUNC - TYPE - SIZE F - 03 - B	4805059
DRAWN: TKELLEY			

REAR VIEW

PLACE IN CABLE TRAY

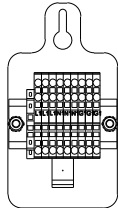

*NOTE

CUT 3P MALE END OFF OF CABLE. STRIP 3" OF INSULATION OFF OF CABLE, THEN STRIP .25" OFF EACH WIRE AND TERMINATE TO PT PANEL

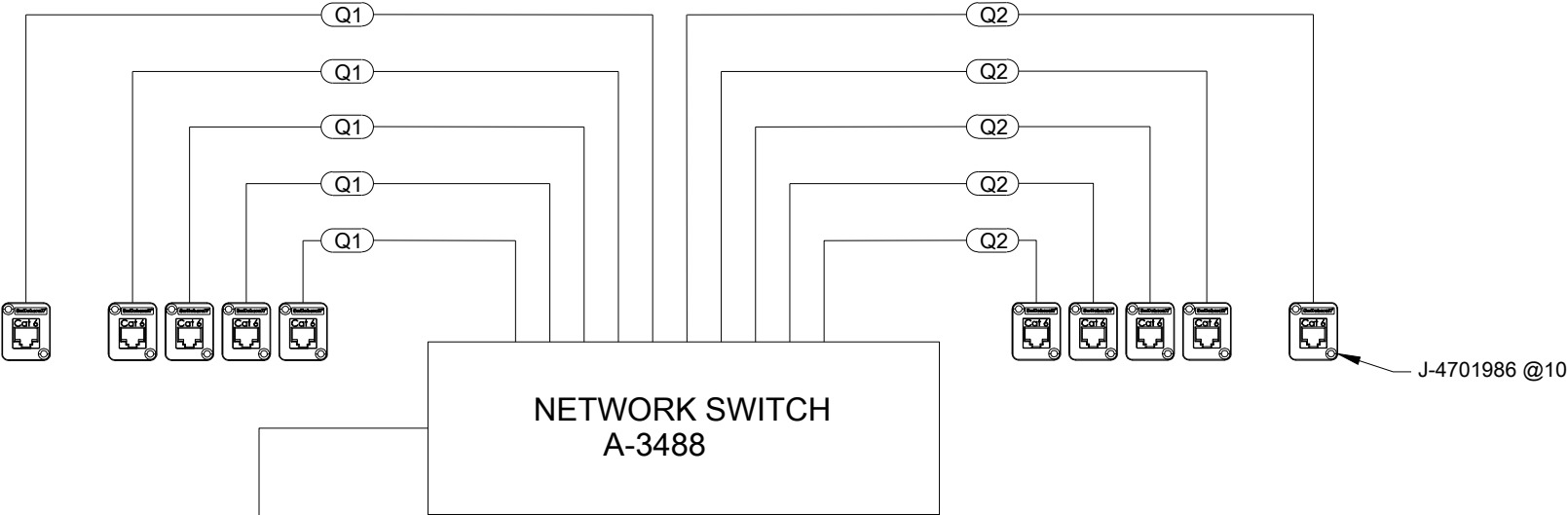

*NOTE
PLUG NETWORK CABLES INTO CLOSEST AVAILABLE PORT.

- 10 @ J-4701986 JACK; 8 PIN FEM, RJ45,PANEL MOUNT COUPLER
- 5 @ W-1732 CABLE; CAT 5E BLACK RJ45-RJ45; 42"; 4 PAIR
- 5 @ W-1733 CABLE; CAT 5E BLACK RJ45-RJ45; 84" 4 PAIR
- 1 @ A-3488 NETWORK SWITCH; 10-PORT, GIGABIT, MANAGED, 1RU

REV 01	DATE: 30 AUG 21	CN126606 REMOVED A-3253 POWER STRIP. REMOVED W-1633 POWER CORD AS ITS NOT NEEDED	BY: JSF
		THE CONCEPTS EXPRESSED AND DETAILS SHOWN ON THIS DRAWING ARE CONFIDENTIAL AND PROPRIETARY. DO NOT REPRODUCE BY ANY MEANS WITHOUT THE EXPRESS WRITTEN CONSENT OF DAKTRONICS, INC. OR ITS WHOLLY OWNED SUBSIDIARIES. COPYRIGHT 2021 DAKTRONICS, INC. (USA)	THIRD ANGLE PROJECTION
PROJECT: ST-B1			
TITLE: BLOCK DIAGRAM; NETWORK KIT, DOMESTIC			
DATE: 27 JAN 21	DIM UNITS: INCHES [MILLIMETERS]	SHEET	REV 01
SCALE: NTS	DO NOT SCALE DRAWING		
DESIGN: JFIXSEN	JOB NO. P2307	FUNC - TYPE - SIZE F - 03 - B	4805597
DRAWN: TKELLEY			

ST-31X0-3.9MN-192X768-120V-EMBEDDED
 ST-31X0-5.9MN-126X504-120V-EMBEDDED

EACH TABLE REQUIRES TWO 20A DEDICATED CIRCUITS

DISPLAY POWER REQUIREMENTS				
PIXEL PITCH	DISPLAY SIZE	EACH TABLE		VOLTAGE
		WATTS	AMPS	
ST-31X0-3.9MN	192X768	1524	12.7	120V
OUTLETS		1,200	10	120V
ST-31X0-5.9MN	126X504	1524	12.7	120V
OUTLETS		1,200	10	120V

NOTE: POWER REQUIREMENTS SHOWN ARE FOR THE DISPLAY, PLUS 1,200 WATTS OF RECEPTACLE LOAD.

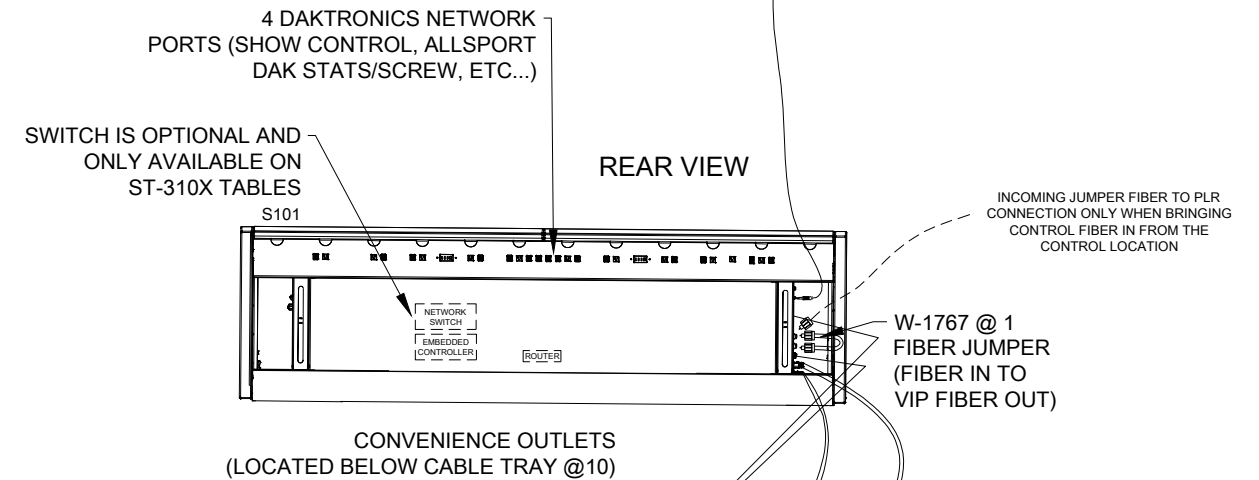
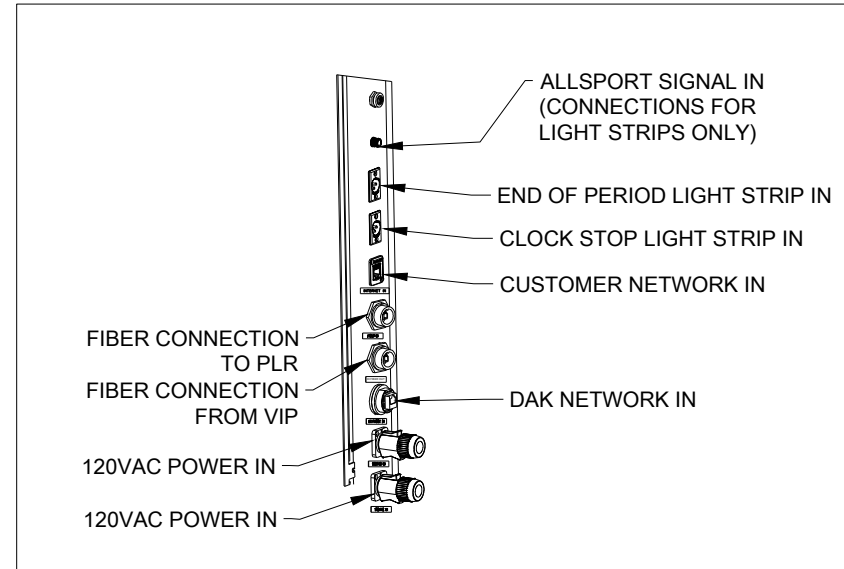
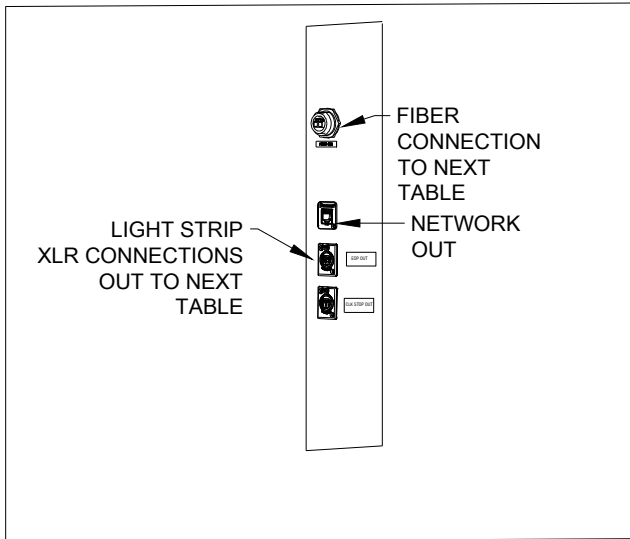

* NOTE LIGHT STRIPS DO NOT COME AS STANDARD THEY ARE OPTIONAL EQUIPMENT

POWER DISTRIBUTION SYSTEM LEGEND

FEEDER TABLE - 2 CONDUCTORS+GND (SEE SPECIFICATIONS FOR INSULATION TYPE)				
OVER CURRENT PROTECTION AMPACITY	2 WIRES			
	FDR REF	COPPER WIRE AWG-KCMIL	COPPER GND WIRE AWG	MIN. CONDUIT SIZE
20	A20	(2)12	12	1/2"

NOTES:
 A. CONDUIT SIZES ARE MINIMUM; INCREASE FOR LONG OR DIFFICULT RUNS.
 B. ABOVE 86 F AMBIENT INCREASE WIRE SIZE PER NEC.
 C. CONDUIT AND CONDUCTOR SIZES ARE BASED ON 90° TYPE THIN COPPER CURRENT CARRYING CONDUCTORS IN SCH. 40 PVC CONDUIT, TERMINATING TO 75°C TERMINALS. CONDUIT AND CONDUCTOR SIZES MAY NEED TO BE INCREASED PER LOCAL AND NATIONAL ELECTRIC CODES IF OTHER CONDUCTOR OR CONDUIT TYPES ARE USED.
 D. IF WIRE OR CONDUIT SIZES OTHER THAN THOSE SHOWN IN THESE CHARTS ARE TO BE USED, CONTACT A DAKTRONICS ELECTRICAL ENGINEERING REPRESENTATIVE.

NOTES:
 THE FOLLOWING 200 SERIES ARE NOT SCALED DRAWINGS AND SHOULD BE USED FOR POWER AND SIGNAL REQUIREMENTS ONLY.
 IT IS THE RESPONSIBILITY OF THE INSTALLER TO ENSURE THAT ALL ELECTRICAL WORK PERFORMED ON SITE MEETS OR EXCEEDS ALL LOCAL AND NATIONAL ELECTRICAL CODES.
 ALL SIGNAL CABLE RUNS SHOULD BE LABELED WITH THEIR ORIGIN AND DESTINATION ON EACH END.
 FIBER OPTIC CABLE RUNS MUST BE CONTINUOUS WITH A MINIMUM BEND RADIUS OF 15XO.D. OF THE FIBER CABLE.
 IF A SHIELDED SIGNAL CABLE IS UTILIZED IN YOUR SYSTEM, ENSURE THAT THE CABLES SHIELD IS GROUNDED ON THE DISPLAY END ONLY, AND TO THE SHIELD TERMINAL AT THE SIGNAL CABLE SURGE ARRESTER CARD WHEN AVAILABLE.
 ALL DISPLAYS MUST BE GROUNDED PER ARTICLE 250 AND 600 OF THE NATIONAL ELECTRICAL CODE WITH NO MORE THAN 10 OHMS GROUND RESISTANCE.
 THE OVER CURRENT PROTECTION DEVICE MUST BE MATCHED TO THE FAULT CURRENT THAT IS AVAILABLE IN THE POWER DELIVERY CIRCUIT. TO DETERMINE THE AVAILABLE FAULT CURRENT OF A SITE, AN ONSITE FAULT CURRENT SURVEY MAY NEED TO BE PERFORMED BY QUALIFIED PERSONNEL. IF THE AVAILABLE FAULT CURRENT IN THE ELECTRICAL SYSTEM EXCEEDS 10,000 AMPS, A DAKTRONICS REPRESENTATIVE SHOULD BE CONTACTED.
 DUE TO THE INRUSH CURRENT (MOMENTARY SURGE) CREATED BY THE DISPLAY EQUIPMENT ON STARTUP, THE OVER CURRENT PROTECTION DEVICE(S) MAY HAVE TO BE OVERSIZED.
 DAKTRONICS UTILIZES BOTH STANDARD AND SUPPLEMENTARY CIRCUIT BREAKERS IN THE DISPLAY ASSEMBLY PROCESS. IT IS THE RESPONSIBILITY OF THE INSTALLER TO ENSURE THAT ALL PRIMARY FEEDER CIRCUIT BREAKERS TO EACH DISPLAY/DISPLAY SECTION ARE UL 489 LISTED.
 DAKTRONICS IS NOT RESPONSIBLE FOR THE QUALITY OF THE POWER DELIVERY SYSTEM TO THE DISPLAY SYSTEM.
 BECAUSE EACH INSTALLATION IS UNIQUE, DAKTRONICS OFFERS THESE INSTRUCTIONS AS GUIDELINES ONLY. DAKTRONICS, INC. ASSUMES NO LIABILITY IF INSTALLATION STEPS HAVE BEEN OMITTED OR OTHER NECESSARY PROCEDURES ARE NOT INCLUDED IN THIS SYSTEM RISER DIAGRAM.
 POWER AND SIGNAL REQUIREMENTS ARE SPECIFIED TO THE EQUIPMENT AND SETUP SHOWN. ANY CHANGES MADE TO EQUIPMENT OR THEIR SETUP SHOULD BE DISCUSSED WITH DAKTRONICS DESIGN PERSONNEL AND WILL REQUIRE AN UPDATED RISER DIAGRAM DRAWING.
 THE CONTRACTUAL AGREEMENT WILL DETERMINE THE PARTY OR PARTIES RESPONSIBLE FOR ITEMS LISTED AS FIELD INSTALLED. THIS DRAWING IS NOT INTENDED TO DETERMINE RESPONSIBILITIES AND SHOULD BE USED FOR REFERENCES ONLY.
 ACTUAL PLACEMENT OF ELECTRICAL COMPONENTS, SUCH AS PANEL BOARDS, A/C'S, AND SPLICE PANELS, MAY VARY. PLEASE REFERENCE THE SYSTEM SHOP DRAWING FOR THIS DETAIL. THIS DRAWING REPRESENTS A GENERAL MOUNTING LOCATION ONLY.
 EXTERNALLY MOUNTED HARDWARE
 INTERNALLY MOUNTED HARDWARE

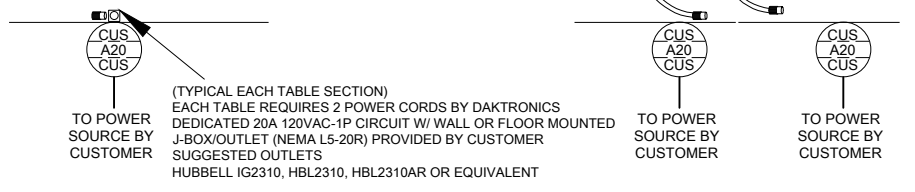

REV 01	DATE: 26 MAY 22	CN140831 ADDED NOTE THAT SWITCH IS OPTIONAL AND ONLY AVAILABLE ON ST-310X TABLES	BY: JSF
		THE CONCEPTS EXPRESSED AND DETAILS SHOWN ON THIS DRAWING ARE CONFIDENTIAL AND PROPRIETARY. DO NOT REPRODUCE BY ANY MEANS WITHOUT THE EXPRESS WRITTEN CONSENT OF DAKTRONICS, INC. OR ITS WHOLLY OWNED SUBSIDIARIES. COPYRIGHT 2021 DAKTRONICS, INC. (USA)	
PROJECT: ST B1			
TITLE: RISER; ST-31XY, 1 TABLE WIDE			
DATE: 30 APR 21	DIM UNITS: INCHES [MILLIMETERS]	SHEET	REV 01
SCALE: NTS	DO NOT SCALE DRAWING		
DESIGN: JFIXSEN	JOB NO. P2307	FUNC - TYPE - SIZE	4856381
DRAWN: JFIXSEN		F - 03 - B	

ST-31X0-3.9MN-192X1536-120V-EMBEDDED
ST-31X0-5.9MN-126X1008-120V-EMBEDDED

****EACH TABLE REQUIRES TWO 20A DEDICATED CIRCUITS****

DISPLAY POWER REQUIREMENTS				
PIXEL PITCH	DISPLAY SIZE	EACH TABLE		VOLTAGE
		WATTS	AMPS	
ST-31X0-3.9MN	192X768	1524	12.7	120V
OUTLETS		1,200	10	120V
ST-31X0-5.9MN	126X504	1524	12.7	120V
OUTLETS		1,200	10	120V

NOTE: POWER REQUIREMENTS SHOWN ARE FOR THE DISPLAY, PLUS 1,200 WATTS OF RECEPTACLE LOAD.

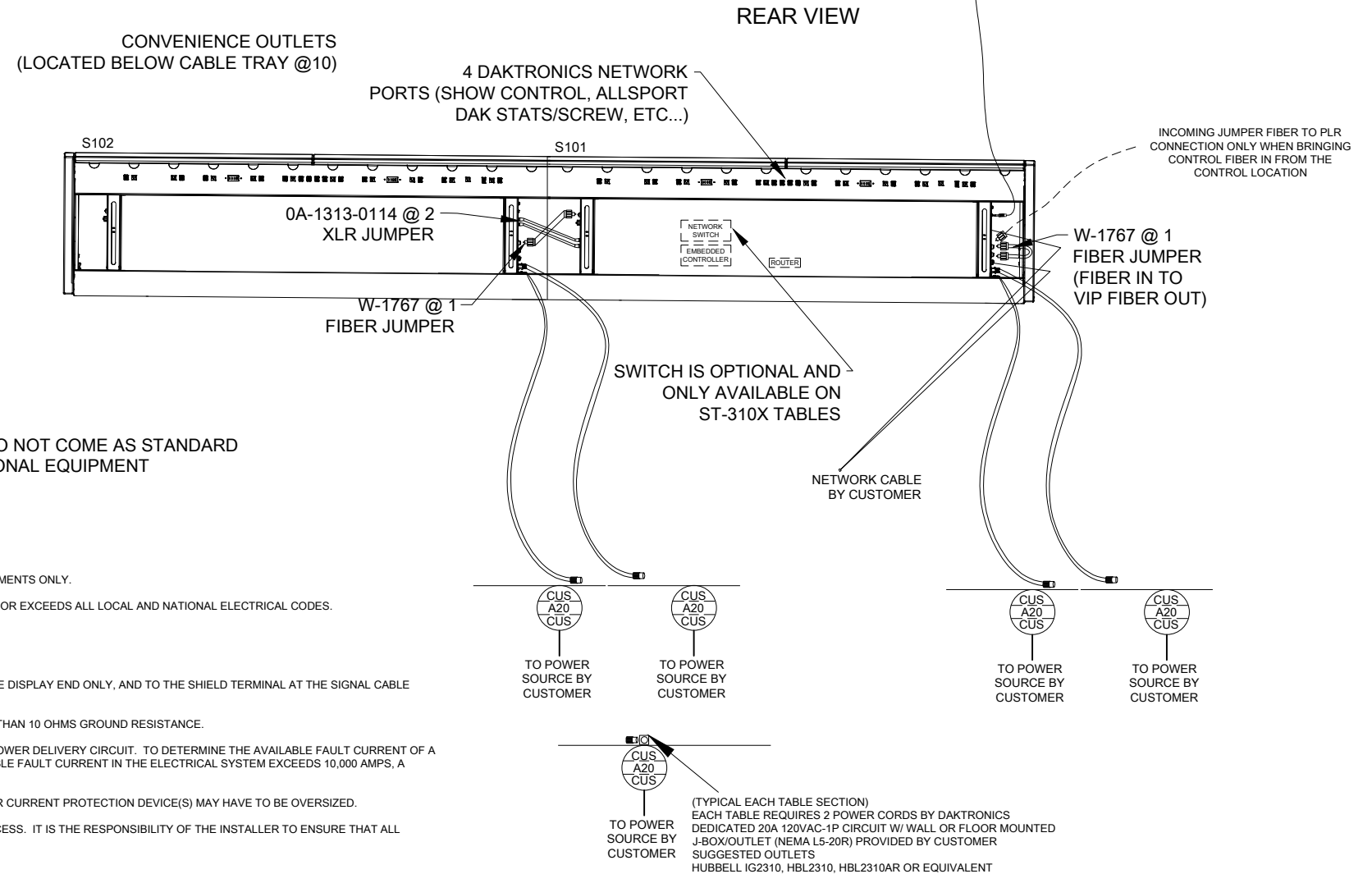
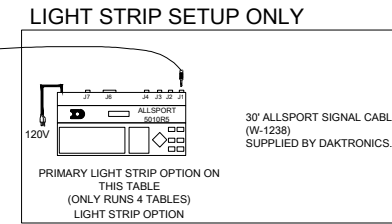
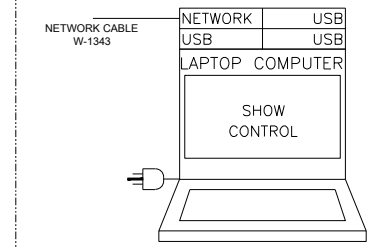
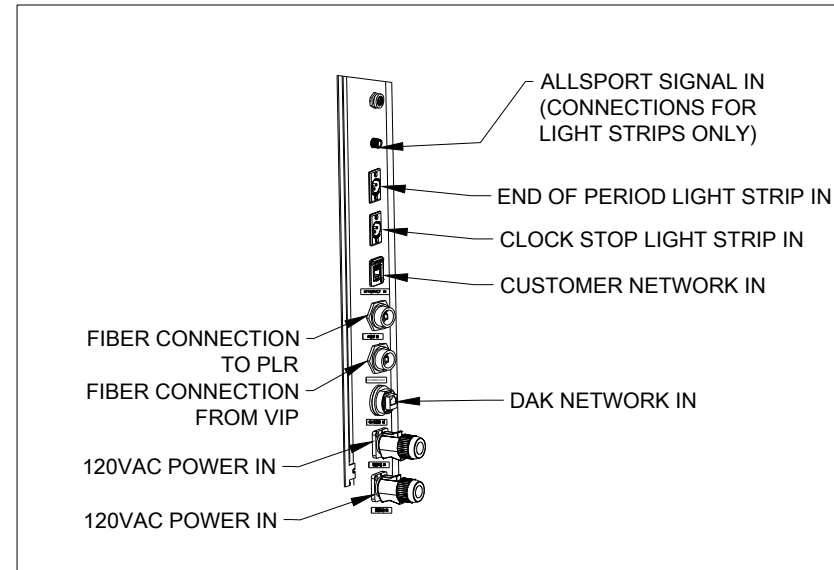
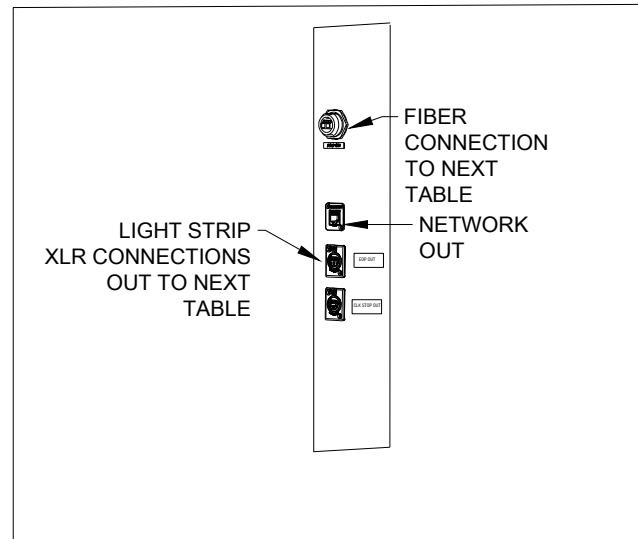

* NOTE
 LIGHT STRIPS DO NOT COME AS STANDARD
 THEY ARE OPTIONAL EQUIPMENT

POWER DISTRIBUTION SYSTEM LEGEND

FEEDER TABLE - 2 CONDUCTORS+GND (SEE SPECIFICATIONS FOR INSULATION TYPE)				
OVER CURRENT PROTECTION AMPACITY	FDR REF	2 WIRES		MIN. CONDUIT SIZE
		COPPER WIRE AWG-KCMIL	COPPER GND WIRE AWG	
20	A20	(2)12	12	1/2"

NOTES:

A. CONDUIT SIZES ARE MINIMUM; INCREASE FOR LONG OR DIFFICULT RUNS.

B. ABOVE 86 F AMBIENT INCREASE WIRE SIZE PER NEC.

C. CONDUIT AND CONDUCTOR SIZES ARE BASED ON 90° TYPE THHN COPPER CURRENT CARRYING CONDUCTORS IN SCH. 40 PVC CONDUIT, TERMINATING TO 75°C TERMINALS. CONDUIT AND CONDUCTOR SIZES MAY NEED TO BE INCREASED PER LOCAL AND NATIONAL ELECTRIC CODES IF OTHER CONDUCTOR OR CONDUIT TYPES ARE USED.

D. IF WIRE OR CONDUIT SIZES OTHER THAN THOSE SHOWN IN THESE CHARTS ARE TO BE USED, CONTACT A DAKTRONICS ELECTRICAL ENGINEERING REPRESENTATIVE.

NOTES:

THE FOLLOWING 200 SERIES ARE NOT SCALED DRAWINGS AND SHOULD BE USED FOR POWER AND SIGNAL REQUIREMENTS ONLY.

IT IS THE RESPONSIBILITY OF THE INSTALLER TO ENSURE THAT ALL ELECTRICAL WORK PERFORMED ON SITE MEETS OR EXCEEDS ALL LOCAL AND NATIONAL ELECTRICAL CODES.

ALL SIGNAL CABLE RUNS SHOULD BE LABELED WITH THEIR ORIGIN AND DESTINATION ON EACH END.

FIBER OPTIC CABLE RUNS MUST BE CONTINUOUS WITH A MINIMUM BEND RADIUS OF 15XO.D. OF THE FIBER CABLE.

IF A SHIELDED SIGNAL CABLE IS UTILIZED IN YOUR SYSTEM, ENSURE THAT THE CABLES SHIELD IS GROUNDED ON THE DISPLAY END ONLY, AND TO THE SHIELD TERMINAL AT THE SIGNAL CABLE SURGE ARRESTER CARD WHEN AVAILABLE.

ALL DISPLAYS MUST BE GROUNDED PER ARTICLE 250 AND 600 OF THE NATIONAL ELECTRICAL CODE WITH NO MORE THAN 10 OHMS GROUND RESISTANCE.

THE OVER CURRENT PROTECTION DEVICE MUST BE MATCHED TO THE FAULT CURRENT THAT IS AVAILABLE IN THE POWER DELIVERY CIRCUIT. TO DETERMINE THE AVAILABLE FAULT CURRENT OF A SITE, AN ONSITE FAULT CURRENT SURVEY MAY NEED TO BE PERFORMED BY QUALIFIED PERSONNEL. IF THE AVAILABLE FAULT CURRENT IN THE ELECTRICAL SYSTEM EXCEEDS 10,000 AMPS, A DAKTRONICS REPRESENTATIVE SHOULD BE CONTACTED.

DUE TO THE INRUSH CURRENT (MOMENTARY SURGE) CREATED BY THE DISPLAY EQUIPMENT ON STARTUP, THE OVER CURRENT PROTECTION DEVICE(S) MAY HAVE TO BE OVERSIZED.

DAKTRONICS UTILIZES BOTH STANDARD AND SUPPLEMENTARY CIRCUIT BREAKERS IN THE DISPLAY ASSEMBLY PROCESS. IT IS THE RESPONSIBILITY OF THE INSTALLER TO ENSURE THAT ALL PRIMARY FEEDER CIRCUIT BREAKERS TO EACH DISPLAY/DISPLAY SECTION ARE UL 489 LISTED.

DAKTRONICS IS NOT RESPONSIBLE FOR THE QUALITY OF THE POWER DELIVERY SYSTEM TO THE DISPLAY SYSTEM.

BECAUSE EACH INSTALLATION IS UNIQUE, DAKTRONICS OFFERS THESE INSTRUCTIONS AS GUIDELINES ONLY. DAKTRONICS, INC. ASSUMES NO LIABILITY IF INSTALLATION STEPS HAVE BEEN OMITTED OR OTHER NECESSARY PROCEDURES ARE NOT INCLUDED IN THIS SYSTEM RISER DIAGRAM.

POWER AND SIGNAL REQUIREMENTS ARE SPECIFIED TO THE EQUIPMENT AND SETUP SHOWN. ANY CHANGES MADE TO EQUIPMENT OR THEIR SETUP SHOULD BE DISCUSSED WITH DAKTRONICS DESIGN PERSONNEL AND WILL REQUIRE AN UPDATED RISER DIAGRAM DRAWING.

THE CONTRACTUAL AGREEMENT WILL DETERMINE THE PARTY OR PARTIES RESPONSIBLE FOR ITEMS LISTED AS FIELD INSTALLED. THIS DRAWING IS NOT INTENDED TO DETERMINE RESPONSIBILITIES AND SHOULD BE USED FOR REFERENCES ONLY.

ACTUAL PLACEMENT OF ELECTRICAL COMPONENTS, SUCH AS PANEL BOARDS, A/C'S, AND SPLICE PANELS, MAY VARY. PLEASE REFERENCE THE SYSTEM SHOP DRAWING FOR THIS DETAIL. THIS DRAWING REPRESENTS A GENERAL MOUNTING LOCATION ONLY.

EXTERNALLY MOUNTED HARDWARE
 INTERNALLY MOUNTED HARDWARE

REV 01	DATE: 26 MAY 22	CN140831 ADDED NOTE THAT SWITCH IS OPTIONAL AND ONLY AVAILABLE ON ST-310X TABLES	BY: JSF	PROJECT: ST-31XT	TITLE: RISER; ST-31XY, 2 TABLE WIDE	DATE: 03 MAY 21	DIM UNITS: INCHES [MILLIMETERS]	SHEET 01	REV 01
				SCALE: NTS	DO NOT SCALE DRAWING				
				DESIGN: JFIXSEN	JOB NO. P2307	FUNC - TYPE - SIZE F - 03 - B		4857853	
				DRAWN: JFIXSEN					

DAKTRONICS

THE CONCEPTS EXPRESSED AND DETAILS SHOWN ON THIS DRAWING ARE CONFIDENTIAL AND PROPRIETARY. DO NOT REPRODUCE BY ANY MEANS WITHOUT THE EXPRESS WRITTEN CONSENT OF DAKTRONICS, INC. OR ITS WHOLLY OWNED SUBSIDIARIES. COPYRIGHT 2021 DAKTRONICS, INC. (USA)

THIRD ANGLE PROJECTION

PROJECT: ST-31XT
 TITLE: RISER; ST-31XY, 2 TABLE WIDE
 DATE: 03 MAY 21
 SCALE: NTS
 DESIGN: JFIXSEN
 DRAWN: JFIXSEN

DIM UNITS: INCHES [MILLIMETERS]
 DO NOT SCALE DRAWING
 JOB NO. P2307
 FUNC - TYPE - SIZE F - 03 - B

SHEET 01
 REV 01

4857853

ST-31X0-3.9MN-192X2304-120V-EMBEDDED
ST-31X0-5.9MN-126X1512-120V-EMBEDDED

****EACH TABLE REQUIRES TWO 20A DEDICATED CIRCUITS****

DISPLAY POWER REQUIREMENTS				
		EACH TABLE		
PIXEL PITCH	DISPLAY SIZE	WATTS	AMPS	VOLTAGE
ST-31X0-3.9MN	192X768	1524	12.7	120V
OUTLETS		1,200	10	120V
ST-31X0-5.9MN	126X504	1524	12.7	120V
OUTLETS		1,200	10	120V

NOTE: POWER REQUIREMENTS SHOWN ARE FOR THE DISPLAY, PLUS 1,200 WATTS OF RECEPTACLE LOAD.

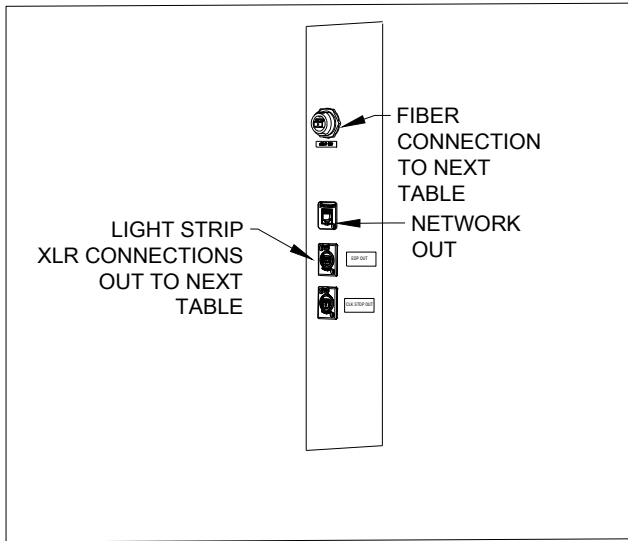

* NOTE
 LIGHT STRIPS DO NOT COME AS STANDARD
 THEY ARE OPTIONAL EQUIPMENT

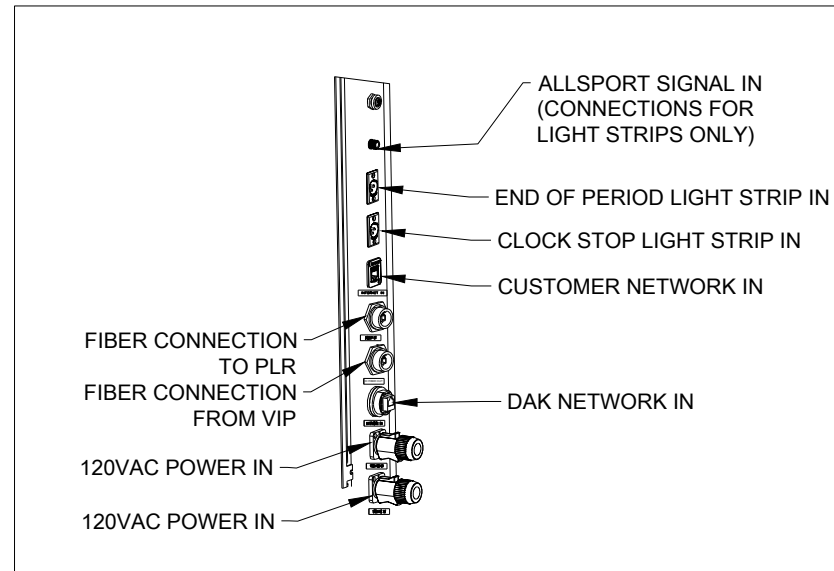

REAR VIEW

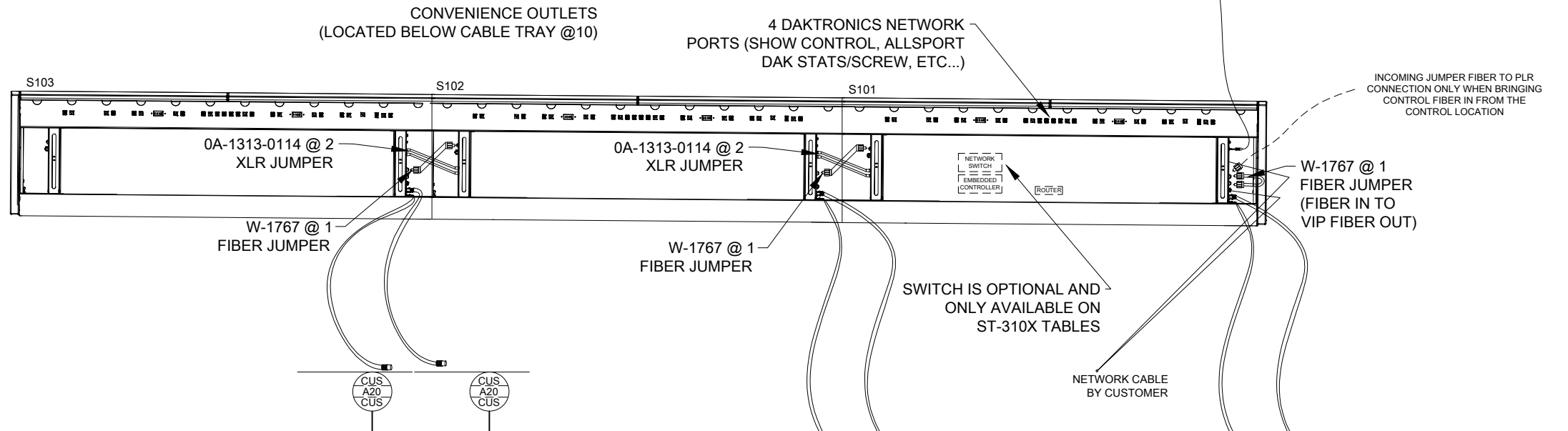
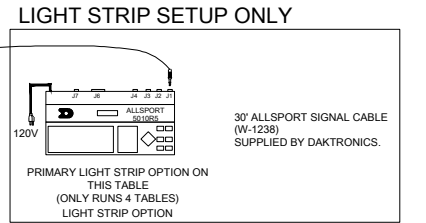
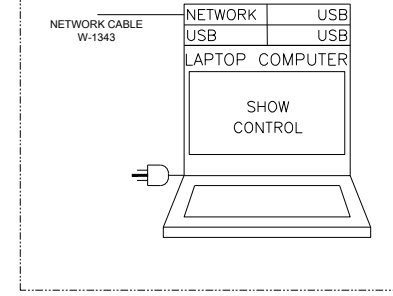

POWER DISTRIBUTION SYSTEM LEGEND

FEEDER TABLE - 2 CONDUCTORS+GND (SEE SPECIFICATIONS FOR INSULATION TYPE)				
OVER CURRENT PROTECTION AMPACITY	2 WIRES			MIN. CONDUIT SIZE
	FDR REF	COPPER WIRE AWG-KCML	COPPER GND WIRE AWG	
20	A20	(2)12	12	1/2"

NOTES:
 THE FOLLOWING 200 SERIES ARE NOT SCALED DRAWINGS AND SHOULD BE USED FOR POWER AND SIGNAL REQUIREMENTS ONLY.
 IT IS THE RESPONSIBILITY OF THE INSTALLER TO ENSURE THAT ALL ELECTRICAL WORK PERFORMED ON SITE MEETS OR EXCEEDS ALL LOCAL AND NATIONAL ELECTRICAL CODES.
 ALL SIGNAL CABLE RUNS SHOULD BE LABELED WITH THEIR ORIGIN AND DESTINATION ON EACH END.
 FIBER OPTIC CABLE RUNS MUST BE CONTINUOUS WITH A MINIMUM BEND RADIUS OF 15XO.D. OF THE FIBER CABLE.
 IF A SHIELDED SIGNAL CABLE IS UTILIZED IN YOUR SYSTEM, ENSURE THAT THE CABLES SHIELD IS GROUNDED ON THE DISPLAY END ONLY, AND TO THE SHIELD TERMINAL AT THE SIGNAL CABLE SURGE ARRESTER CARD WHEN AVAILABLE.
 ALL DISPLAYS MUST BE GROUNDED PER ARTICLE 250 AND 600 OF THE NATIONAL ELECTRICAL CODE WITH NO MORE THAN 10 OHMS GROUND RESISTANCE.
 THE OVER CURRENT PROTECTION DEVICE MUST BE MATCHED TO THE FAULT CURRENT THAT IS AVAILABLE IN THE POWER DELIVERY CIRCUIT. TO DETERMINE THE AVAILABLE FAULT CURRENT OF A SITE, AN ONSITE FAULT CURRENT SURVEY MAY NEED TO BE PERFORMED BY QUALIFIED PERSONNEL. IF THE AVAILABLE FAULT CURRENT IN THE ELECTRICAL SYSTEM EXCEEDS 10,000 AMPS, A DAKTRONICS REPRESENTATIVE SHOULD BE CONTACTED.
 DUE TO THE INRUSH CURRENT (MOMENTARY SURGE) CREATED BY THE DISPLAY EQUIPMENT ON STARTUP, THE OVER CURRENT PROTECTION DEVICE(S) MAY HAVE TO BE OVERSIZED.
 DAKTRONICS UTILIZES BOTH STANDARD AND SUPPLEMENTARY CIRCUIT BREAKERS IN THE DISPLAY ASSEMBLY PROCESS. IT IS THE RESPONSIBILITY OF THE INSTALLER TO ENSURE THAT ALL PRIMARY FEEDER CIRCUIT BREAKERS TO EACH DISPLAY/DISPLAY SECTION ARE UL 489 LISTED.
 DAKTRONICS IS NOT RESPONSIBLE FOR THE QUALITY OF THE POWER DELIVERY SYSTEM TO THE DISPLAY SYSTEM.
 BECAUSE EACH INSTALLATION IS UNIQUE, DAKTRONICS OFFERS THESE INSTRUCTIONS AS GUIDELINES ONLY. DAKTRONICS, INC. ASSUMES NO LIABILITY IF INSTALLATION STEPS HAVE BEEN OMITTED OR OTHER NECESSARY PROCEDURES ARE NOT INCLUDED IN THIS SYSTEM RISER DIAGRAM.
 POWER AND SIGNAL REQUIREMENTS ARE SPECIFIED TO THE EQUIPMENT AND SETUP SHOWN. ANY CHANGES MADE TO EQUIPMENT OR THEIR SETUP SHOULD BE DISCUSSED WITH DAKTRONICS DESIGN PERSONNEL AND WILL REQUIRE AN UPDATED RISER DIAGRAM DRAWING.
 THE CONTRACTUAL AGREEMENT WILL DETERMINE THE PARTY OR PARTIES RESPONSIBLE FOR ITEMS LISTED AS FIELD INSTALLED. THIS DRAWING IS NOT INTENDED TO DETERMINE RESPONSIBILITIES AND SHOULD BE USED FOR REFERENCES ONLY.
 ACTUAL PLACEMENT OF ELECTRICAL COMPONENTS, SUCH AS PANEL BOARDS, A/C'S, AND SPLICE PANELS, MAY VARY. PLEASE REFERENCE THE SYSTEM SHOP DRAWING FOR THIS DETAIL. THIS DRAWING REPRESENTS A GENERAL MOUNTING LOCATION ONLY.

EXTERNALLY MOUNTED HARDWARE
 INTERNALLY MOUNTED HARDWARE

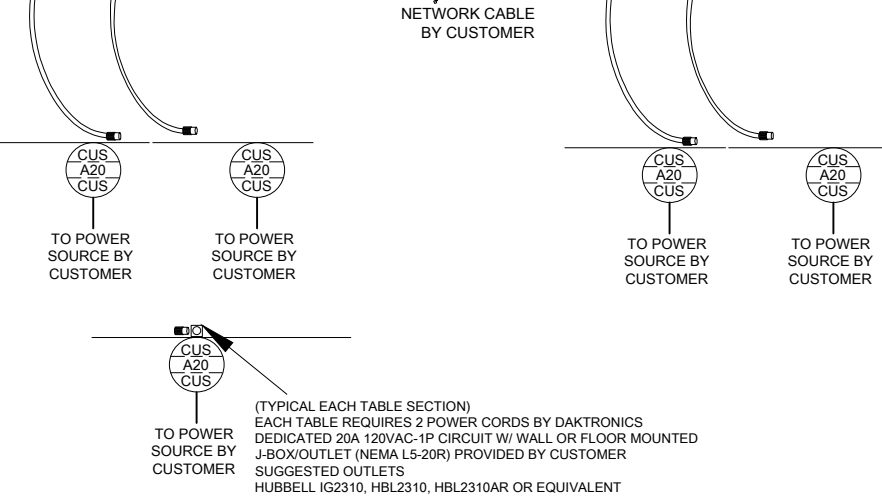

(TYPICAL EACH TABLE SECTION)
 EACH TABLE REQUIRES 2 POWER CORDS BY DAKTRONICS DEDICATED 20A 120VAC-1P CIRCUIT W/ WALL OR FLOOR MOUNTED J-BOX/OUTLET (NEMA L5-20R) PROVIDED BY CUSTOMER SUGGESTED OUTLETS HUBBELL IG2310, HBL2310, HBL2310AR OR EQUIVALENT

DAKTRONICS THE CONCEPTS EXPRESSED AND DETAILS SHOWN ON THIS DRAWING ARE CONFIDENTIAL AND PROPRIETARY. DO NOT REPRODUCE BY ANY MEANS WITHOUT THE EXPRESS WRITTEN CONSENT OF DAKTRONICS, INC. OR ITS WHOLLY OWNED SUBSIDIARIES. COPYRIGHT 2021 DAKTRONICS, INC. (USA)

THIRD ANGLE PROJECTION

PROJECT: ST-31XY	TITLE: RISER; ST-31XY 3 TABLE WIDE	DATE: 03 MAY 21	DIM UNITS: INCHES [MILLIMETERS]	SHEET	REV
SCALE: NTS	DO NOT SCALE DRAWING	DESIGN: JFIXSEN	JOB NO. P2307	FUNC - TYPE - SIZE	F - 03 - B
DRAWN: JFIXSEN					4857865

REV 01	DATE: 26 MAY 22	CN140831 ADDED NOTE THAT SWITCH IS OPTIONAL AND ONLY AVAILABLE ON ST-310X TABLES	BY: JSF
--------	-----------------	--	---------

ST-31X0-3.9MN-192X3072-120V-EMBEDDED
ST-31X0-5.9MN-126X2016-120V-EMBEDDED

EACH TABLE REQUIRES TWO 20A DEDICATED CIRCUITS

DISPLAY POWER REQUIREMENTS EACH TABLE				
PIXEL PITCH	DISPLAY SIZE	WATTS	AMPS	VOLTAGE
ST-31X0-3.9MN	192X768	1524	12.7	120V
OUTLETS		1,200	10	120V
ST-31X0-5.9MN	126X504	1524	12.7	120V
OUTLETS		1,200	10	120V

NOTE: POWER REQUIREMENTS SHOWN ARE FOR THE DISPLAY, PLUS 1,200 WATTS OF RECEPTACLE LOAD.

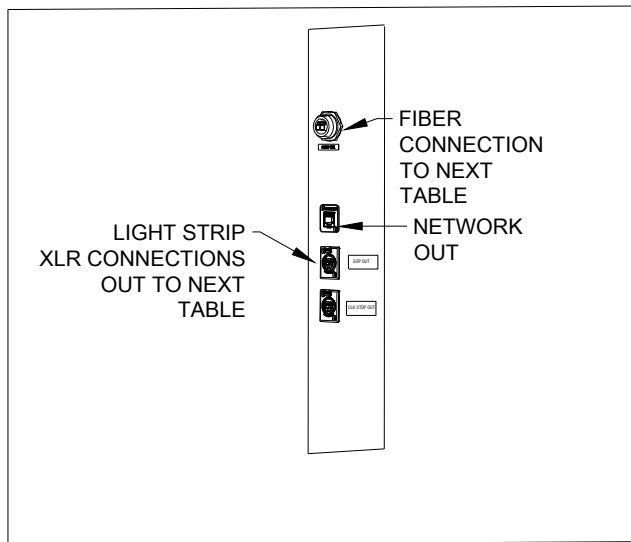

* NOTE
LIGHT STRIPS DO NOT COME AS STANDARD
THEY ARE OPTIONAL EQUIPMENT

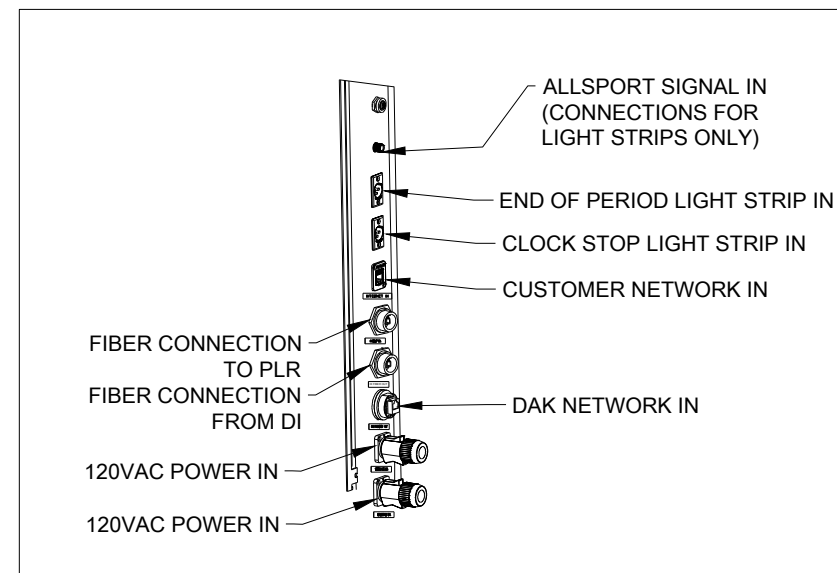

REAR VIEW

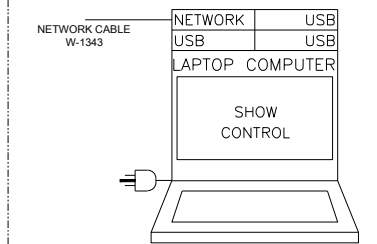

LIGHT STRIP SETUP ONLY

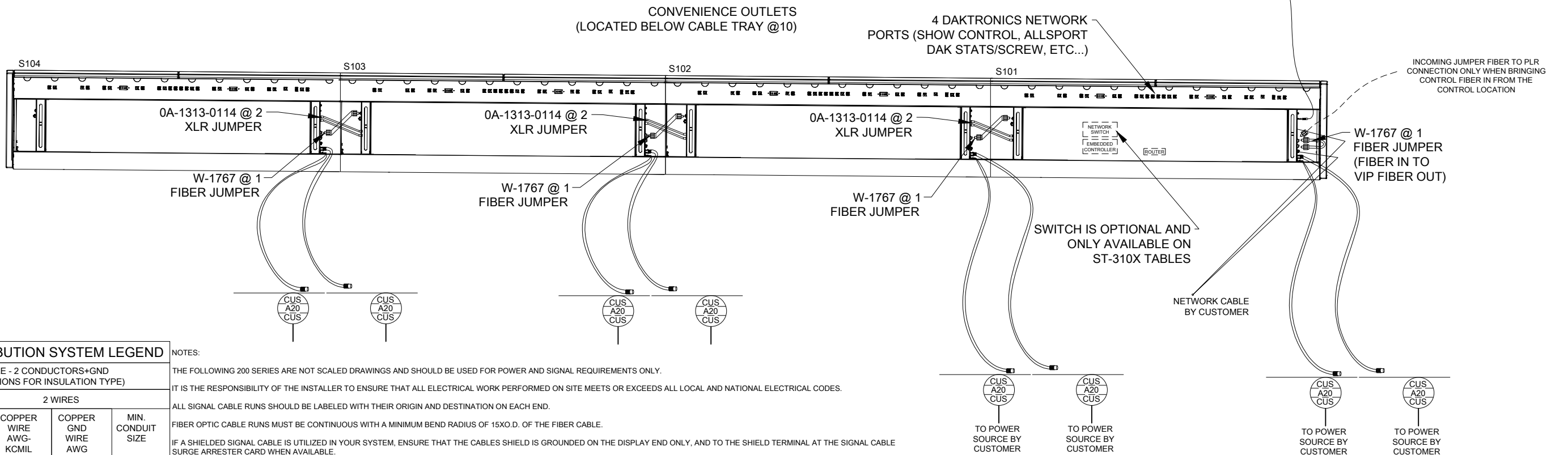
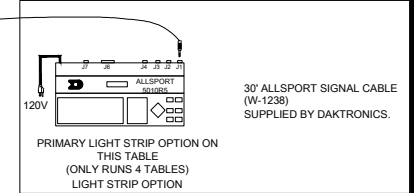

POWER DISTRIBUTION SYSTEM LEGEND

FEEDER TABLE - 2 CONDUCTORS+GND (SEE SPECIFICATIONS FOR INSULATION TYPE)				
OVER CURRENT PROTECTION AMPACITY	2 WIRES			
	FDR REF	COPPER WIRE AWG-KCMIL	COPPER GND WIRE AWG	MIN. CONDUIT SIZE
20	A20	(2)12	12	1/2"

NOTES:

- CONDUIT SIZES ARE MINIMUM; INCREASE FOR LONG OR DIFFICULT RUNS.
- ABOVE 86 F AMBIENT INCREASE WIRE SIZE PER NEC.
- CONDUIT AND CONDUCTOR SIZES ARE BASED ON 90° TYPE THHN COPPER CURRENT CARRYING CONDUCTORS IN SCH. 40 PVC CONDUIT, TERMINATING TO 75°C TERMINALS. CONDUIT AND CONDUCTOR SIZES MAY NEED TO BE INCREASED PER LOCAL AND NATIONAL ELECTRIC CODES IF OTHER CONDUCTOR OR CONDUIT TYPES ARE USED.
- IF WIRE OR CONDUIT SIZES OTHER THAN THOSE SHOWN IN THESE CHARTS ARE TO BE USED, CONTACT A DAKTRONICS ELECTRICAL ENGINEERING REPRESENTATIVE.

NOTES:

- THE FOLLOWING 200 SERIES ARE NOT SCALED DRAWINGS AND SHOULD BE USED FOR POWER AND SIGNAL REQUIREMENTS ONLY.
- IT IS THE RESPONSIBILITY OF THE INSTALLER TO ENSURE THAT ALL ELECTRICAL WORK PERFORMED ON SITE MEETS OR EXCEEDS ALL LOCAL AND NATIONAL ELECTRICAL CODES.
- ALL SIGNAL CABLE RUNS SHOULD BE LABELED WITH THEIR ORIGIN AND DESTINATION ON EACH END.
- FIBER OPTIC CABLE RUNS MUST BE CONTINUOUS WITH A MINIMUM BEND RADIUS OF 15XO.D. OF THE FIBER CABLE.
- IF A SHIELDED SIGNAL CABLE IS UTILIZED IN YOUR SYSTEM, ENSURE THAT THE CABLES SHIELD IS GROUNDED ON THE DISPLAY END ONLY, AND TO THE SHIELD TERMINAL AT THE SIGNAL CABLE SURGE ARRESTER CARD WHEN AVAILABLE.
- ALL DISPLAYS MUST BE GROUNDED PER ARTICLE 250 AND 600 OF THE NATIONAL ELECTRICAL CODE WITH NO MORE THAN 10 OHMS GROUND RESISTANCE.
- THE OVER CURRENT PROTECTION DEVICE MUST BE MATCHED TO THE FAULT CURRENT THAT IS AVAILABLE IN THE POWER DELIVERY CIRCUIT. TO DETERMINE THE AVAILABLE FAULT CURRENT OF A SITE, AN ONSITE FAULT CURRENT SURVEY MAY NEED TO BE PERFORMED BY QUALIFIED PERSONNEL. IF THE AVAILABLE FAULT CURRENT IN THE ELECTRICAL SYSTEM EXCEEDS 10,000 AMPS, A DAKTRONICS REPRESENTATIVE SHOULD BE CONTACTED.
- DUE TO THE INRUSH CURRENT (MOMENTARY SURGE) CREATED BY THE DISPLAY EQUIPMENT ON STARTUP, THE OVER CURRENT PROTECTION DEVICE(S) MAY HAVE TO BE OVERSIZED.
- DAKTRONICS UTILIZES BOTH STANDARD AND SUPPLEMENTARY CIRCUIT BREAKERS IN THE DISPLAY ASSEMBLY PROCESS. IT IS THE RESPONSIBILITY OF THE INSTALLER TO ENSURE THAT ALL PRIMARY FEEDER CIRCUIT BREAKERS TO EACH DISPLAY/DISPLAY SECTION ARE UL 489 LISTED.
- DAKTRONICS IS NOT RESPONSIBLE FOR THE QUALITY OF THE POWER DELIVERY SYSTEM TO THE DISPLAY SYSTEM.
- BECAUSE EACH INSTALLATION IS UNIQUE, DAKTRONICS OFFERS THESE INSTRUCTIONS AS GUIDELINES ONLY. DAKTRONICS, INC. ASSUMES NO LIABILITY IF INSTALLATION STEPS HAVE BEEN OMITTED OR OTHER NECESSARY PROCEDURES ARE NOT INCLUDED IN THIS SYSTEM RISER DIAGRAM.
- POWER AND SIGNAL REQUIREMENTS ARE SPECIFIED TO THE EQUIPMENT AND SETUP SHOWN. ANY CHANGES MADE TO EQUIPMENT OR THEIR SETUP SHOULD BE DISCUSSED WITH DAKTRONICS DESIGN PERSONNEL AND WILL REQUIRE AN UPDATED RISER DIAGRAM DRAWING.
- THE CONTRACTUAL AGREEMENT WILL DETERMINE THE PARTY OR PARTIES RESPONSIBLE FOR ITEMS LISTED AS FIELD INSTALLED. THIS DRAWING IS NOT INTENDED TO DETERMINE RESPONSIBILITIES AND SHOULD BE USED FOR REFERENCES ONLY.
- ACTUAL PLACEMENT OF ELECTRICAL COMPONENTS, SUCH AS PANEL BOARDS, A/C'S, AND SPLICE PANELS, MAY VARY. PLEASE REFERENCE THE SYSTEM SHOP DRAWING FOR THIS DETAIL. THIS DRAWING REPRESENTS A GENERAL MOUNTING LOCATION ONLY.

EXTERNALLY MOUNTED HARDWARE
INTERNALLY MOUNTED HARDWARE

(TYPICAL EACH TABLE SECTION)
EACH TABLE REQUIRES 2 POWER CORDS BY DAKTRONICS DEDICATED 20A 120VAC-1P CIRCUIT W/ WALL OR FLOOR MOUNTED J-BOX/OUTLET (NEMA L5-20R) PROVIDED BY CUSTOMER SUGGESTED OUTLETS HUBBELL I62310, HBL2310, HBL2310AR OR EQUIVALENT

		THE CONCEPTS EXPRESSED AND DETAILS SHOWN ON THIS DRAWING ARE CONFIDENTIAL AND PROPRIETARY. DO NOT REPRODUCE BY ANY MEANS WITHOUT THE EXPRESS WRITTEN CONSENT OF DAKTRONICS, INC. OR ITS WHOLLY OWNED SUBSIDIARIES. COPYRIGHT 2021 DAKTRONICS, INC. (USA)			
PROJECT: ST-31XY					
TITLE: RISER; ST-31XY, 4 TABLE WIDE					
DATE: 03 MAY 21		DIM UNITS: INCHES [MILLIMETERS]		SHEET	
SCALE: NTS		DO NOT SCALE DRAWING		REV 01	
DESIGN: JFIXSEN		JOB NO. P2307		FUNC - TYPE - SIZE	
DRAWN: JFIXSEN		F - 03 - B		4857875	

REV 01	DATE: 26 MAY 22	CN140831 ADDED NOTE THAT SWITCH IS OPTIONAL AND ONLY AVAILABLE ON ST-310X TABLES	BY: JSF
--------	-----------------	--	---------

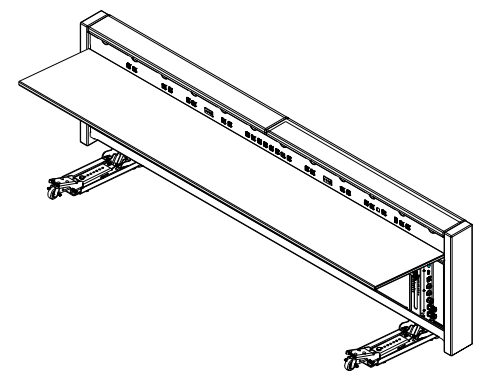
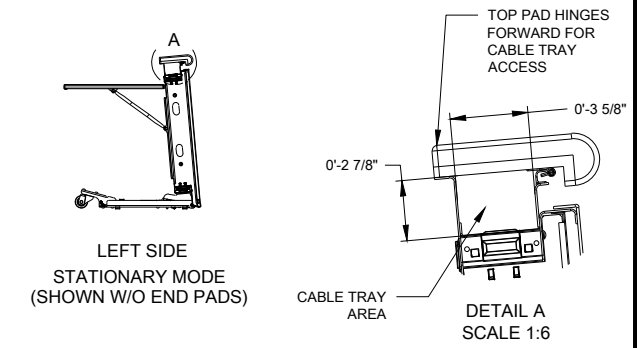
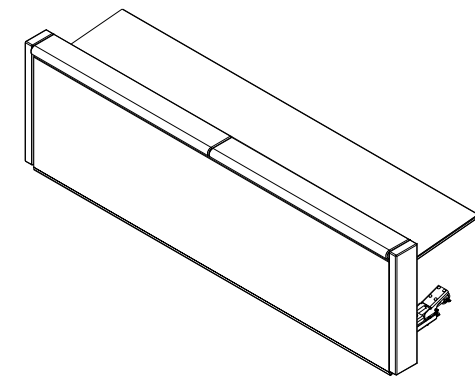
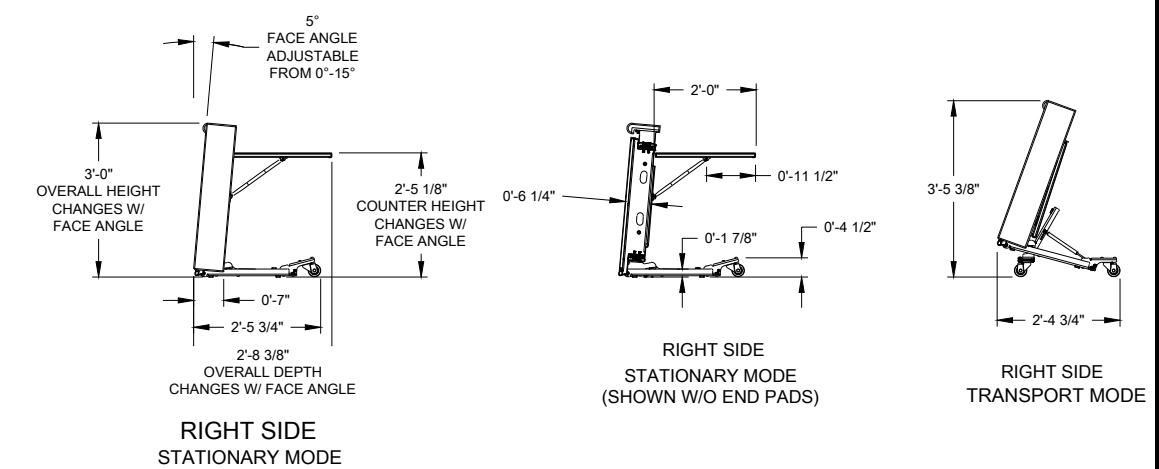
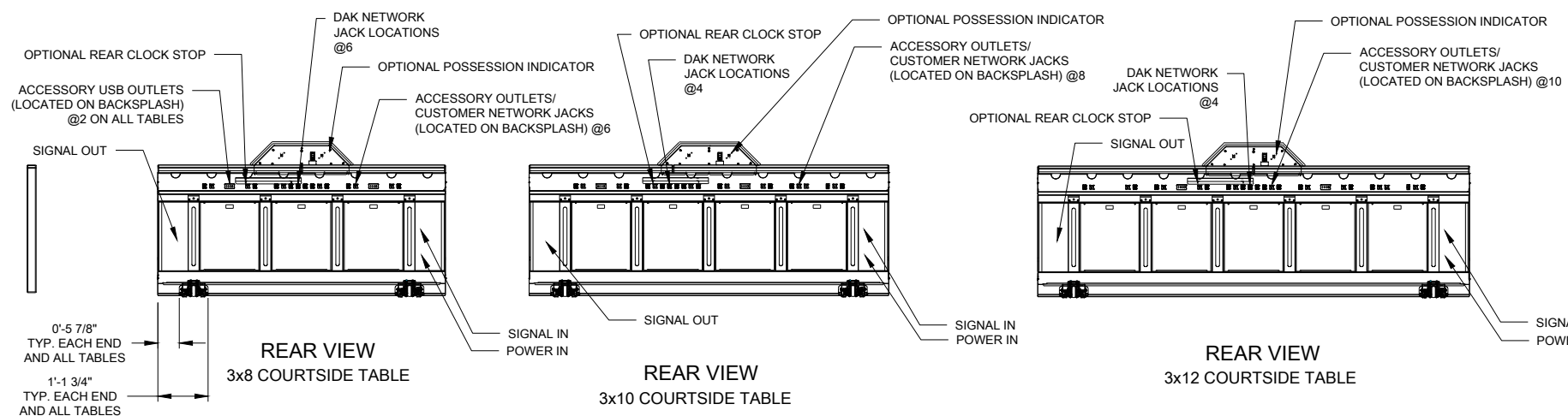
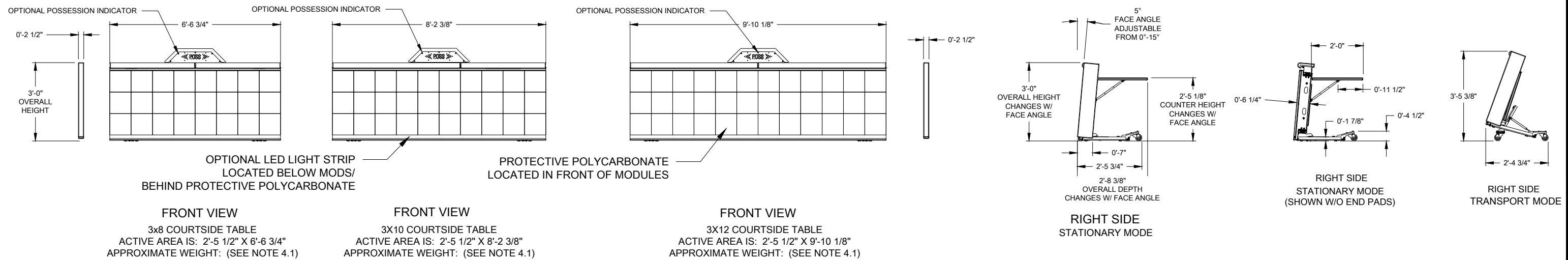

- 1.0 REFERENCE
- 1.1 REFER TO DAKTRONICS PROPOSAL DRAWING FOR DISPLAY COMPONENT SPECIFICATIONS.
 - 1.2 REFER TO DAKTRONICS SYSTEM RISER DRAWING FOR POWER AND SIGNAL SPECIFICATIONS.
- 2.0 GENERAL NOTES
- 2.1 ALL DIMENSIONS IN FEET AND INCHES.
 - 2.2 PAINT PLAN:
DISPLAY CABINETS: SATIN BLACK
 - 2.3 REFER TO INSTALLATION AND MAINTENANCE MANUAL FOR COMPLETE INSTALLATION INSTRUCTIONS.
- 3.0 DISPLAY NOTES
- 3.1 DAKTRONICS DISPLAYS ARE ALUMINUM/STEEL CONSTRUCTION.
 - 3.2 DAKTRONICS SCORE TABLES ARE FRONT AND REAR SERVICE.
 - 3.3 SIGNAL DISTRIBUTION IS LOCATED IN THE REAR OF THE TABLE.
 - 3.4 POWER DISTRIBUTION IS LOCATED IN THE REAR OF THE TABLE.

- 4.0 STRUCTURAL NOTES
- 4.1 ESTIMATED WEIGHT- 315 LBS EACH FOR 3X12 SECTIONS
260 LBS EACH FOR 3X10 SECTIONS
210 LBS EACH FOR 3X8 SECTIONS
AN ADDITIONAL 35 LBS FOR EACH SECTION WITH EMBEDDED CONTROL
AN ADDITIONAL 15 LBS FOR EACH SET OF 2 END PADS
 - 4.2 ANY NON-DAKTRONICS SUPPLIED EQUIPMENT SPECIFICATIONS MUST BE SUBMITTED TO DAKTRONICS PRIOR TO DISPLAY FINAL DESIGN.
 - 4.3 ALL SCORETABLE ASSEMBLY HARDWARE SHALL BE PROVIDED BY DAKTRONICS.
- 5.0 PROJECT RESPONSIBILITIES
- 5.1 ALL ON-SITE WORK TO BE DONE IN ACCORDANCE WITH OSHA AND ALL LOCAL CODES THAT APPLY.
 - 5.2 DAKTRONICS SUBCONTRACTORS RESPONSIBLE FOR JOBSITE SAFETY.

REV 01	DATE: 20 APRIL 22	ADDED OPTIONAL POSSESSION INDICATOR & REAR CLOCK STOP PER CN-137838	BY: SRL
		THE CONCEPTS EXPRESSED AND DETAILS SHOWN ON THIS DRAWING ARE CONFIDENTIAL AND PROPRIETARY. DO NOT REPRODUCE BY ANY MEANS WITHOUT THE EXPRESS WRITTEN CONSENT OF DAKTRONICS, INC. OR ITS WHOLLY OWNED SUBSIDIARIES. COPYRIGHT 2021 DAKTRONICS, INC. (USA)	
PROJECT: ST-3100 TABLES			
TITLE: MECHANICAL SPEC, ST-3100			
DATE: 14 MAY 21	DIM UNITS: INCHES [MILLIMETERS]	SHEET	REV 01
SCALE: 1/40	DO NOT SCALE DRAWING		
DESIGN: MCARSRU	JOB NO. P2307	FUNC - TYPE - SIZE E - 10 - B	4865593
DRAWN: MCARSRU			

OVERALL DISPLAY
 126X504-5.9MM / 192X768-3.9MM
 ACTIVE AREA: 2'-5-1/2" X 9'-10 1/8"
 APPROXIMATE WEIGHT: 350 LBS

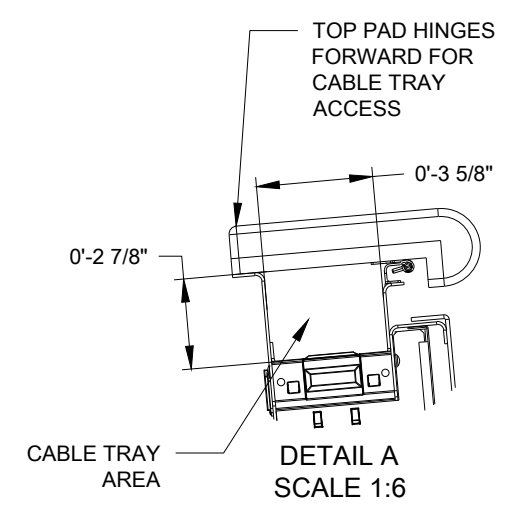
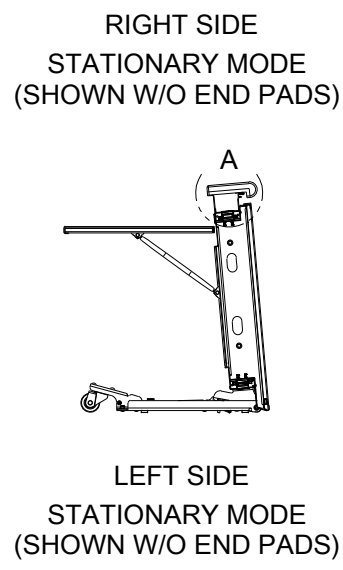
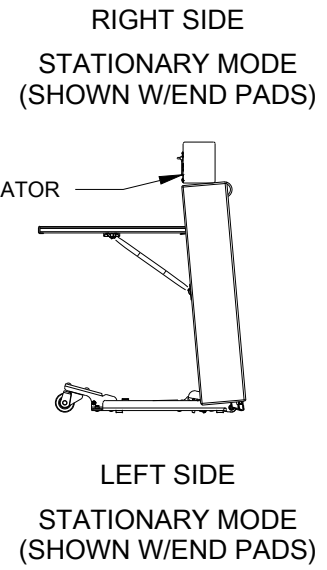
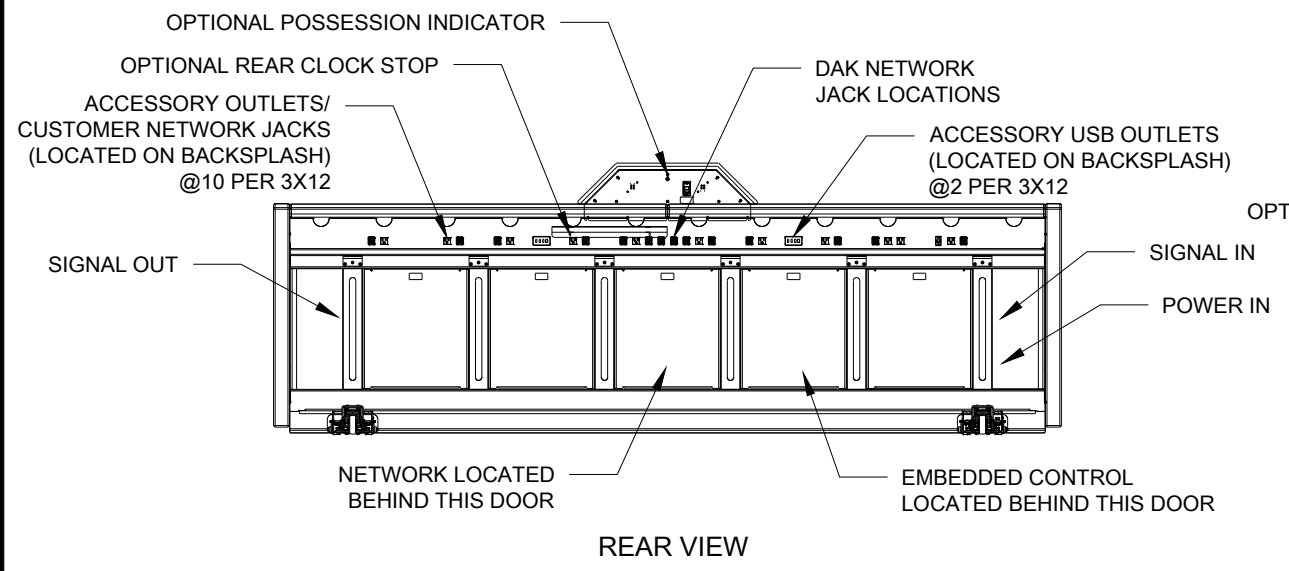
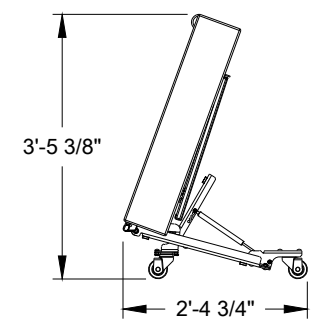
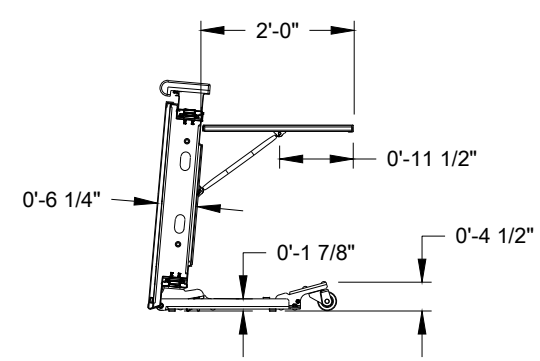
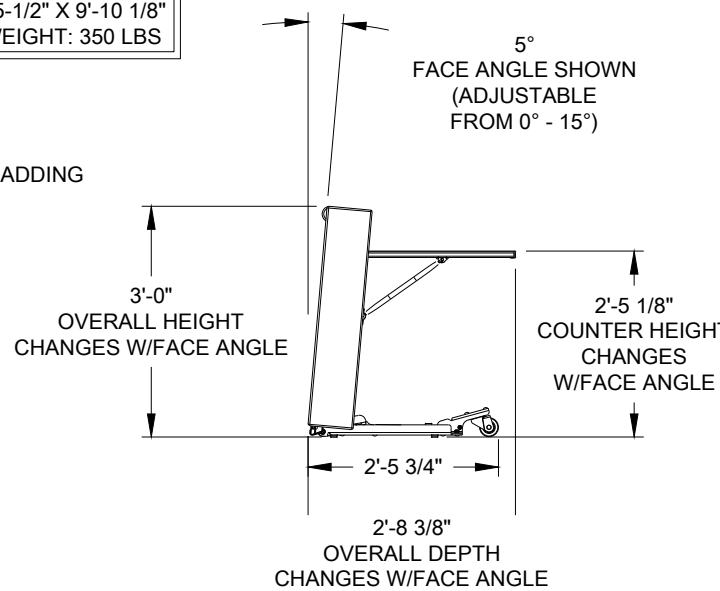
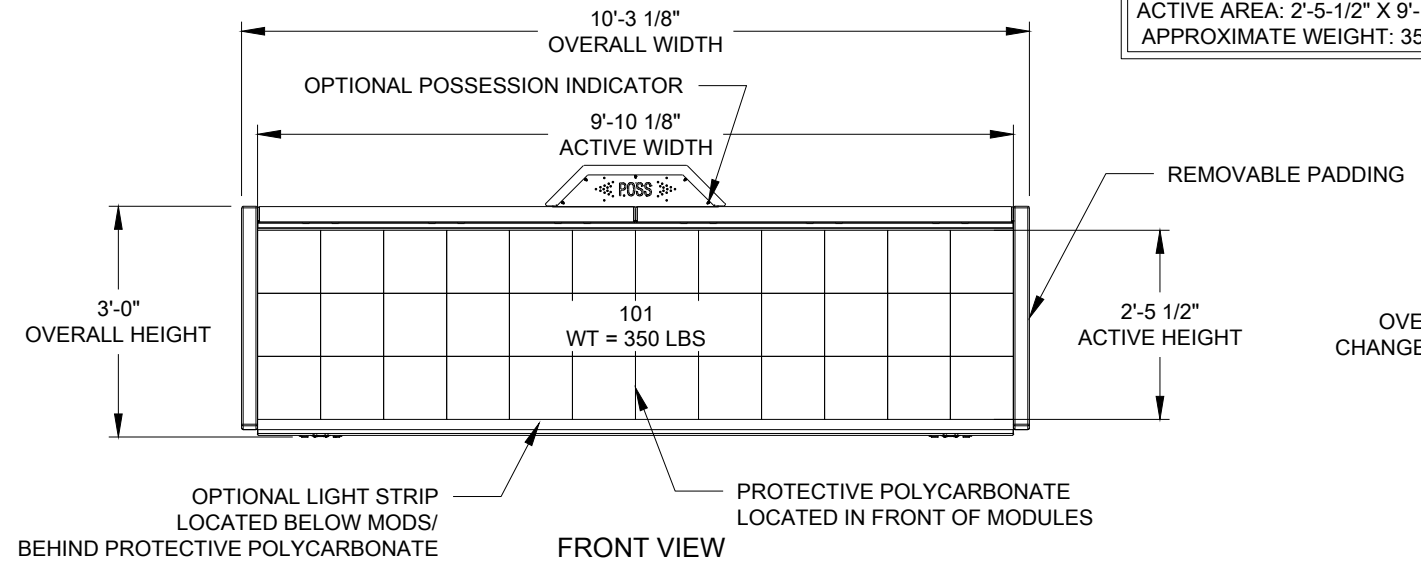

- 1.0 REFERENCE
- 1.1 REFER TO DAKTRONICS PROPOSAL DRAWING FOR DISPLAY COMPONENT SPECIFICATIONS.
 - 1.2 REFER TO DAKTRONICS SYSTEM RISER DRAWING FOR POWER AND SIGNAL SPECIFICATIONS.
- 2.0 GENERAL NOTES
- 2.1 ALL DIMENSIONS IN FEET AND INCHES.
 - 2.2 PAINT PLAN:
 DISPLAY CABINETS: SATIN BLACK
 - 2.3 REFER TO INSTALLATION AND MAINTENANCE MANUAL FOR COMPLETE INSTALLATION INSTRUCTIONS.
- 3.0 DISPLAY NOTES
- 3.1 DAKTRONICS DISPLAYS ARE ALUMINUM/STEEL CONSTRUCTION.
 - 3.2 DAKTRONICS SCORE TABLES ARE FRONT AND REAR SERVICE.
 - 3.3 SIGNAL DISTRIBUTION IS LOCATED IN THE REAR OF THE TABLE.
 - 3.4 POWER DISTRIBUTION IS LOCATED IN THE REAR OF THE TABLE.

- 4.0 STRUCTURAL NOTES
- 4.1 ESTIMATED WEIGHT— 315 LBS EACH FOR 3X12 SECTIONS
 260 LBS EACH FOR 3X10 SECTIONS
 210 LBS EACH FOR 3X8 SECTIONS
 AN ADDITIONAL 35 LBS FOR EACH SECTION WITH EMBEDDED CONTROL
 AN ADDITIONAL 8 LBS FOR EACH SET OF 2 END PADS
 - 4.2 ANY NON-DAKTRONICS SUPPLIED EQUIPMENT SPECIFICATIONS MUST BE SUBMITTED TO DAKTRONICS PRIOR TO DISPLAY FINAL DESIGN.
 - 4.3 ALL SCORETABLE ASSEMBLY HARDWARE SHALL BE PROVIDED BY DAKTRONICS.
- 5.0 PROJECT RESPONSIBILITIES
- 5.1 ALL ON-SITE WORK TO BE DONE IN ACCORDANCE WITH OSHA AND ALL LOCAL CODES THAT APPLY.
 - 5.2 DAKTRONICS SUBCONTRACTORS RESPONSIBLE FOR JOBSITE SAFETY.

REV 02	DATE: 20 APRIL 22	ADDED OPTIONAL POSSESSION INDICATOR & REAR CLOCK STOP PER CN-137838	BY: SRL
REV 01	DATE: 09 FEB 2022	REMOVED THE LOGO OPTION PER CN-134355	BY: SRL
PROJECT: ST B1		TITLE: SHOP; ST-3130, 126X504-5.9/192X768-3.9	
DATE: 4 JUN 21	DIM UNITS: INCHES [MILLIMETERS]	SHEET	REV 02
SCALE: 1/30	DO NOT SCALE DRAWING		
DESIGN: MCARSRU	JOB NO. P2307	FUNC - TYPE - SIZE E - 10 - B	4874201
DRAWN: RBJERKE			

OVERALL DISPLAY
 126X1008-5.9MM / 192X1536-3.9MM
 ACTIVE AREA: 2'-5-1/2" X 19'-8 1/4"
 APPROXIMATE WEIGHT: 665 LBS

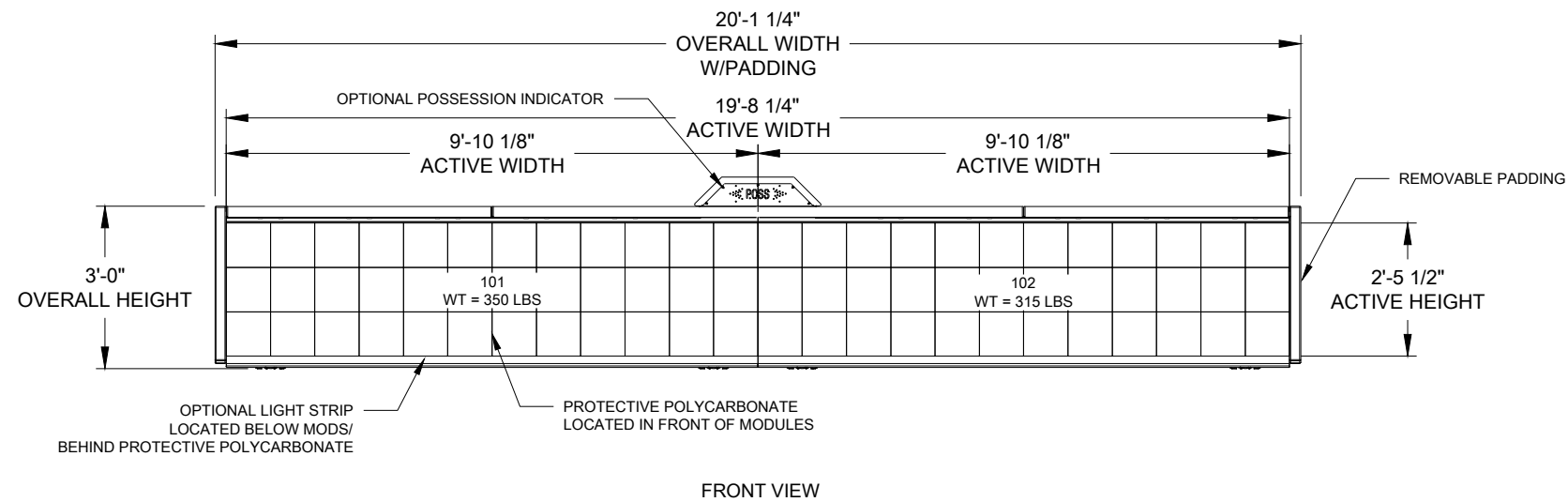

FRONT VIEW

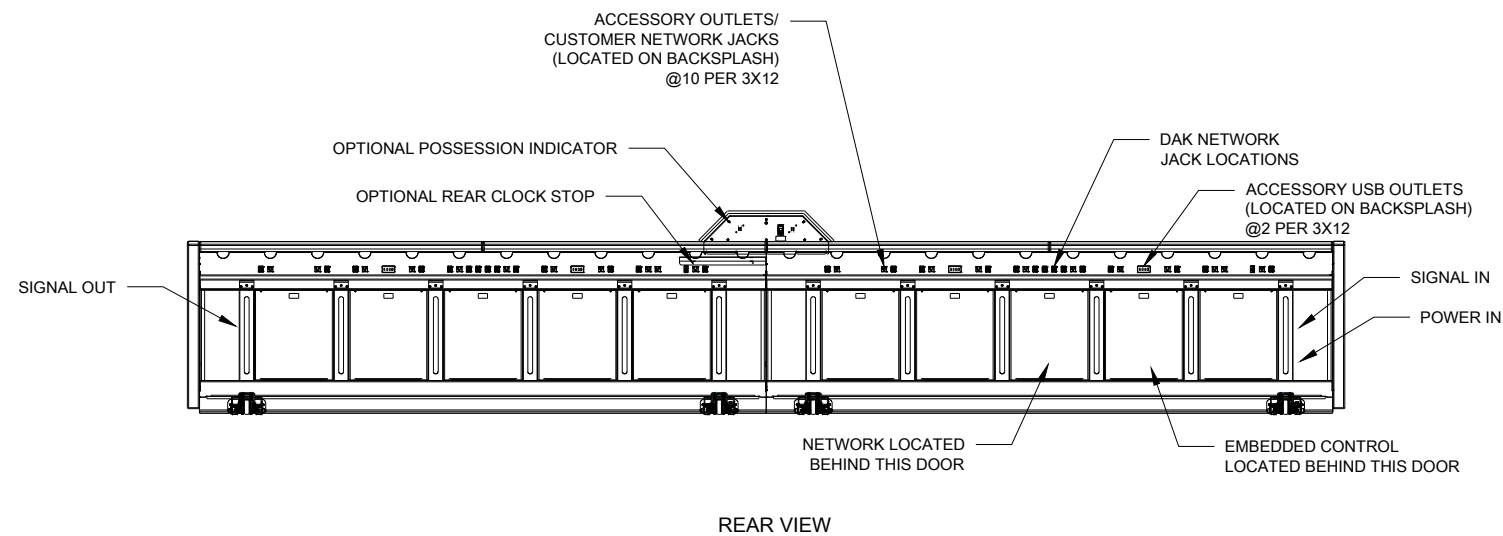
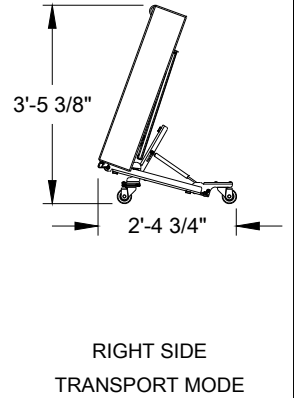
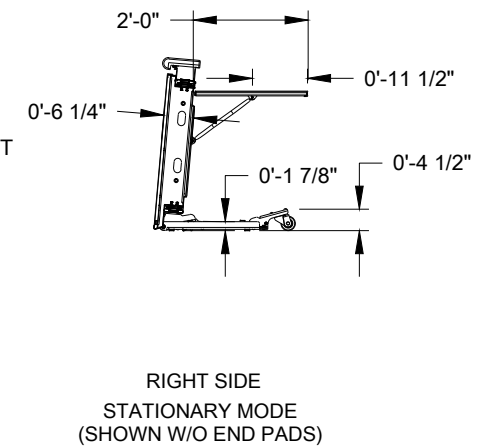
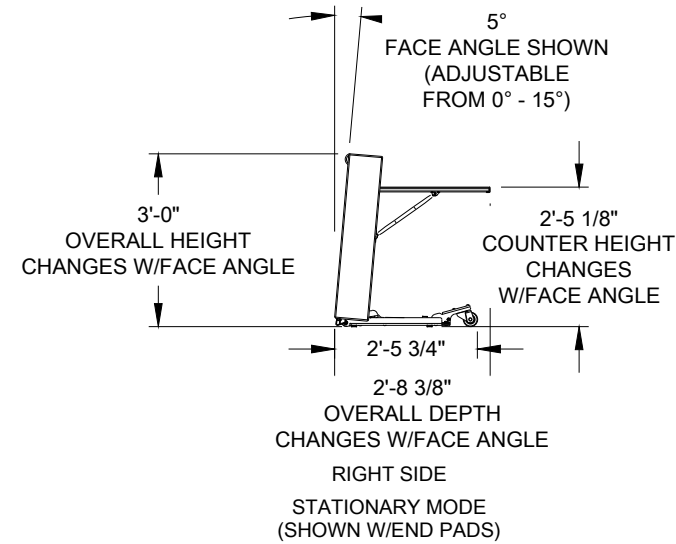

REAR VIEW

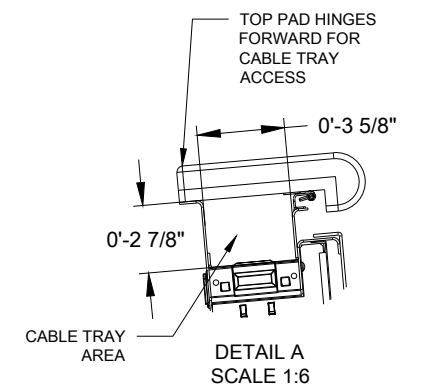
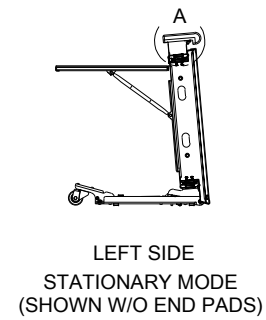
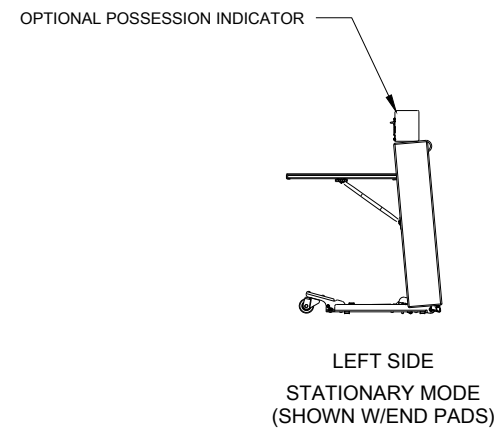

1.0 REFERENCE

- 1.1 REFER TO DAKTRONICS PROPOSAL DRAWING FOR DISPLAY COMPONENT SPECIFICATIONS.
- 1.2 REFER TO DAKTRONICS SYSTEM RISER DRAWING FOR POWER AND SIGNAL SPECIFICATIONS.

2.0 GENERAL NOTES

- 2.1 ALL DIMENSIONS IN FEET AND INCHES.
- 2.2 PAINT PLAN: DISPLAY CABINETS: SATIN BLACK
- 2.3 REFER TO INSTALLATION AND MAINTENANCE MANUAL FOR COMPLETE INSTALLATION INSTRUCTIONS.

3.0 DISPLAY NOTES

- 3.1 DAKTRONICS DISPLAYS ARE ALUMINUM/STEEL CONSTRUCTION.
- 3.2 DAKTRONICS SCORE TABLES ARE FRONT AND REAR SERVICE.
- 3.3 SIGNAL DISTRIBUTION IS LOCATED IN THE REAR OF THE TABLE.
- 3.4 POWER DISTRIBUTION IS LOCATED IN THE REAR OF THE TABLE.

4.0 STRUCTURAL NOTES

- 4.1 ESTIMATED WEIGHT- 315 LBS EACH FOR 3X12 SECTIONS
 260 LBS EACH FOR 3X10 SECTIONS
 210 LBS EACH FOR 3X8 SECTIONS
 AN ADDITIONAL 35 LBS FOR EACH SECTION WITH EMBEDDED CONTROL
 AN ADDITIONAL 8 LBS FOR EACH SET OF 2 END PADS
- 4.2 ANY NON-DAKTRONICS SUPPLIED EQUIPMENT SPECIFICATIONS MUST BE SUBMITTED TO DAKTRONICS PRIOR TO DISPLAY FINAL DESIGN.
- 4.3 ALL SCORETABLE ASSEMBLY HARDWARE SHALL BE PROVIDED BY DAKTRONICS.

5.0 PROJECT RESPONSIBILITIES

- 5.1 ALL ON-SITE WORK TO BE DONE IN ACCORDANCE WITH OSHA AND ALL LOCAL CODES THAT APPLY.
- 5.2 DAKTRONICS SUBCONTRACTORS RESPONSIBLE FOR JOBSITE SAFETY.

REV 02	DATE: 20 APRIL 22	ADDED OPTIONAL POSSESSION INDICATOR & REAR CLOCK STOP PER CN-137638	BY: SRL
REV 01	DATE: 09 FEB 2022	REMOVED THE LOGO OPTION PER CN-134355	BY: SRL

THE CONCEPTS EXPRESSED AND DETAILS SHOWN ON THIS DRAWING ARE CONFIDENTIAL AND PROPRIETARY. DO NOT REPRODUCE BY ANY MEANS WITHOUT THE EXPRESS WRITTEN CONSENT OF DAKTRONICS, INC. OR ITS WHOLLY OWNED SUBSIDIARIES. COPYRIGHT 2021 DAKTRONICS, INC. (USA)

THIRD ANGLE PROJECTION

PROJECT: ST B1
 TITLE: SHOP; ST-3130, 126X1008-5.9/192X1536-3.9
 DATE: 4 JUN 21 DIM UNITS: INCHES [MILLIMETERS] SHEET 02
 SCALE: 1/40 DO NOT SCALE DRAWING
 DESIGN: MCARSRU JOB NO. P2307 FUNC - TYPE - SIZE E - 10 - B
 DRAWN: RBJERKE 4879040

OVERALL DISPLAY
 126X1512-5.9MM / 192X2304-3.9MM
 ACTIVE AREA: 2'-5-1/2" X 29'-6 3/8"
 APPROXIMATE WEIGHT: 980 LBS

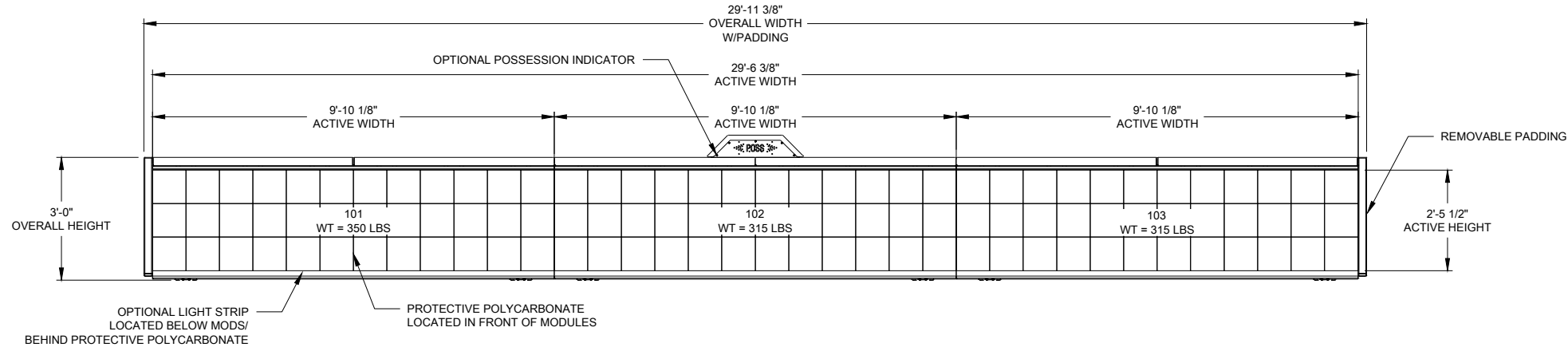

FRONT VIEW

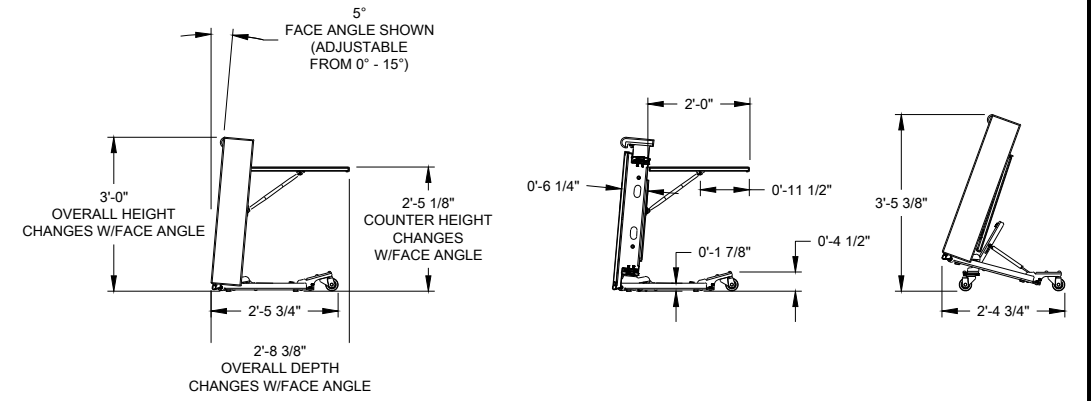

RIGHT SIDE STATIONARY MODE (SHOWN W/END PADS)

RIGHT SIDE STATIONARY MODE (SHOWN W/O END PADS)

RIGHT SIDE TRANSPORT MODE

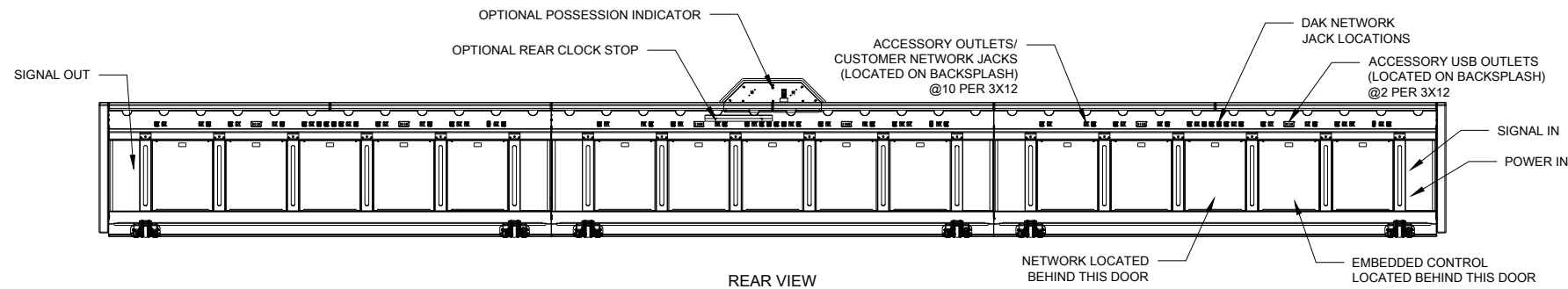

REAR VIEW

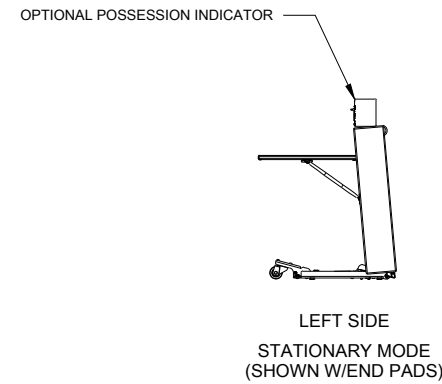

LEFT SIDE STATIONARY MODE (SHOWN W/END PADS)

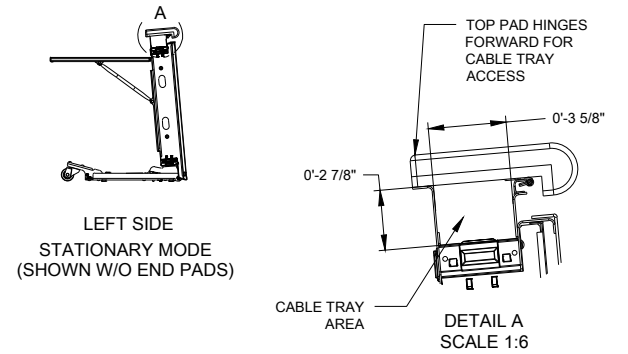

LEFT SIDE STATIONARY MODE (SHOWN W/O END PADS)

1.0 REFERENCE

- 1.1 REFER TO DAKTRONICS PROPOSAL DRAWING FOR DISPLAY COMPONENT SPECIFICATIONS.
- 1.2 REFER TO DAKTRONICS SYSTEM RISER DRAWING FOR POWER AND SIGNAL SPECIFICATIONS.

2.0 GENERAL NOTES

- 2.1 ALL DIMENSIONS IN FEET AND INCHES.
- 2.2 PAINT PLAN: DISPLAY CABINETS: SATIN BLACK
- 2.3 REFER TO INSTALLATION AND MAINTENANCE MANUAL FOR COMPLETE INSTALLATION INSTRUCTIONS.

3.0 DISPLAY NOTES

- 3.1 DAKTRONICS DISPLAYS ARE ALUMINUM/STEEL CONSTRUCTION.
- 3.2 DAKTRONICS SCORE TABLES ARE FRONT AND REAR SERVICE.
- 3.3 SIGNAL DISTRIBUTION IS LOCATED IN THE REAR OF THE TABLE.
- 3.4 POWER DISTRIBUTION IS LOCATED IN THE REAR OF THE TABLE.

4.0 STRUCTURAL NOTES

- 4.1 ESTIMATED WEIGHT- 315 LBS EACH FOR 3X12 SECTIONS
 260 LBS EACH FOR 3X10 SECTIONS
 210 LBS EACH FOR 3X8 SECTIONS
 AN ADDITIONAL 35 LBS FOR EACH SECTION WITH EMBEDDED CONTROL
 AN ADDITIONAL 8 LBS FOR EACH SET OF 2 END PADS
- 4.2 ANY NON-DAKTRONICS SUPPLIED EQUIPMENT SPECIFICATIONS MUST BE SUBMITTED TO DAKTRONICS PRIOR TO DISPLAY FINAL DESIGN.
- 4.3 ALL SCORETABLE ASSEMBLY HARDWARE SHALL BE PROVIDED BY DAKTRONICS.

5.0 PROJECT RESPONSIBILITIES

- 5.1 ALL ON-SITE WORK TO BE DONE IN ACCORDANCE WITH OSHA AND ALL LOCAL CODES THAT APPLY.
- 5.2 DAKTRONICS SUBCONTRACTORS RESPONSIBLE FOR JOBSITE SAFETY.

REV 02	DATE: 20 APRIL 22	ADDED OPTIONAL POSSESSION INDICATOR & REAR CLOCK STOP PER CN-137838	BY: SRL
REV 01	DATE: 09 FEB 2022	REMOVED THE LOGO OPTION PER CN-134355	BY: SRL

THE CONCEPTS EXPRESSED AND DETAILS SHOWN ON THIS DRAWING ARE CONFIDENTIAL AND PROPRIETARY. DO NOT REPRODUCE BY ANY MEANS WITHOUT THE EXPRESS WRITTEN CONSENT OF DAKTRONICS, INC. OR ITS WHOLLY OWNED SUBSIDIARIES. COPYRIGHT 2021 DAKTRONICS, INC. (USA)

THIRD ANGLE PROJECTION

PROJECT: ST B1
 TITLE: SHOP; ST-3130, 126X1512-5.9/192X2304-3.9
 DATE: 4 JUN 21 DIM UNITS: INCHES [MILLIMETERS] SHEET 02
 SCALE: 1/45 DO NOT SCALE DRAWING
 DESIGN: MCARSRU JOB NO. P2307 FUNC - TYPE - SIZE E - 10 - B
 DRAWN: RBJERKE 4879041

OVERALL DISPLAY
 126X2016-5.9MM / 192X3072-3.9MM
 ACTIVE AREA: 2'-5-1/2" X 39'-4 1/2"
 APPROXIMATE WEIGHT: 1295 LBS

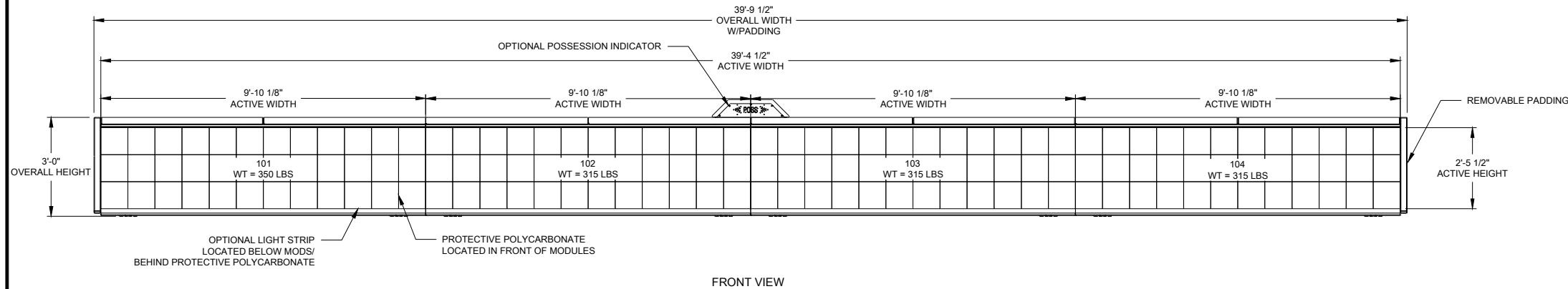

FRONT VIEW

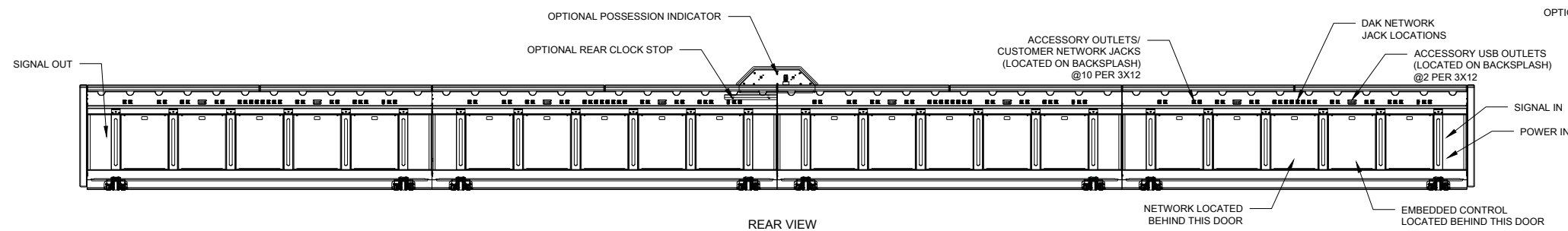
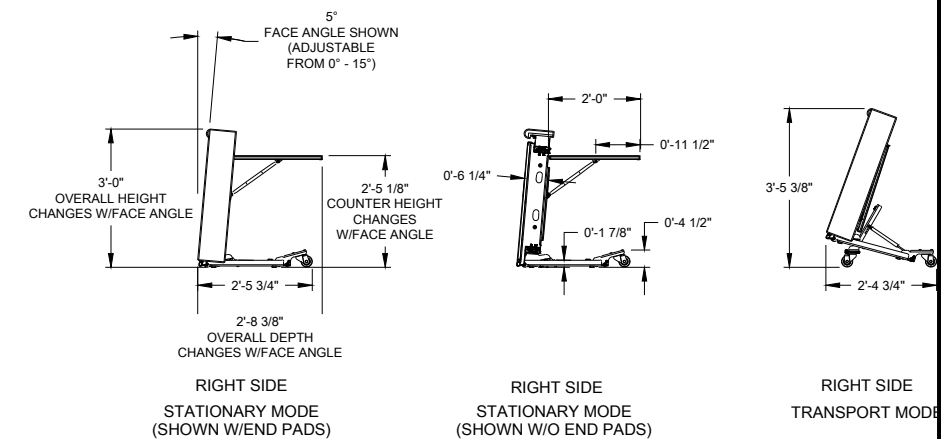

REAR VIEW

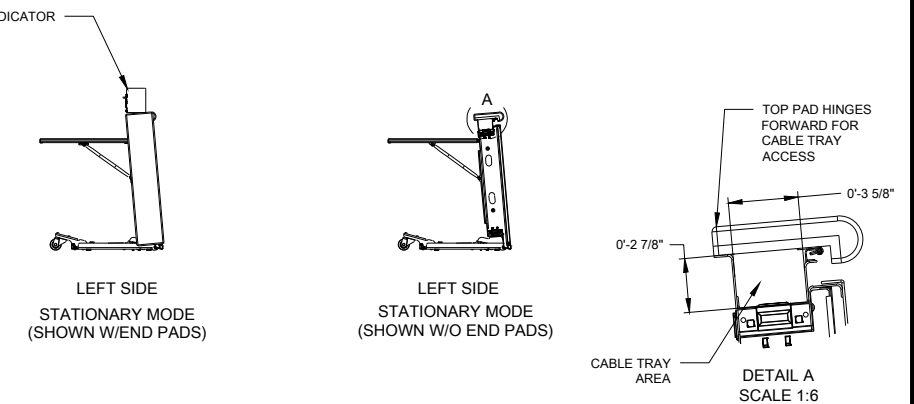

1.0 REFERENCE

- 1.1 REFER TO DAKTRONICS PROPOSAL DRAWING FOR DISPLAY COMPONENT SPECIFICATIONS.
- 1.2 REFER TO DAKTRONICS SYSTEM RISER DRAWING FOR POWER AND SIGNAL SPECIFICATIONS.

2.0 GENERAL NOTES

- 2.1 ALL DIMENSIONS IN FEET AND INCHES.
- 2.2 PAINT PLAN:
 DISPLAY CABINETS: SATIN BLACK
- 2.3 REFER TO INSTALLATION AND MAINTENANCE MANUAL FOR COMPLETE INSTALLATION INSTRUCTIONS.

3.0 DISPLAY NOTES

- 3.1 DAKTRONICS DISPLAYS ARE ALUMINUM/STEEL CONSTRUCTION.
- 3.2 DAKTRONICS SCORE TABLES ARE FRONT AND REAR SERVICE.
- 3.3 SIGNAL DISTRIBUTION IS LOCATED IN THE REAR OF THE TABLE.
- 3.4 POWER DISTRIBUTION IS LOCATED IN THE REAR OF THE TABLE.

4.0 STRUCTURAL NOTES

- 4.1 ESTIMATED WEIGHT- 315 LBS EACH FOR 3X12 SECTIONS
 260 LBS EACH FOR 3X10 SECTIONS
 210 LBS EACH FOR 3X8 SECTIONS
 AN ADDITIONAL 35 LBS FOR EACH SECTION WITH EMBEDDED CONTROL
 AN ADDITIONAL 8 LBS FOR EACH SET OF 2 END PADS
- 4.2 ANY NON-DAKTRONICS SUPPLIED EQUIPMENT SPECIFICATIONS MUST BE SUBMITTED TO DAKTRONICS PRIOR TO DISPLAY FINAL DESIGN.
- 4.3 ALL SCORETABLE ASSEMBLY HARDWARE SHALL BE PROVIDED BY DAKTRONICS.

5.0 PROJECT RESPONSIBILITIES

- 5.1 ALL ON-SITE WORK TO BE DONE IN ACCORDANCE WITH OSHA AND ALL LOCAL CODES THAT APPLY.
- 5.2 DAKTRONICS SUBCONTRACTORS RESPONSIBLE FOR JOBSITE SAFETY.

REV 02	DATE: 20 APRIL 22	ADDED OPTIONAL POSSESSION INDICATOR & REAR CLOCK STOP PER CN-137838	BY: SRL
REV 01	DATE: 09 FEB 2022	REMOVED THE LOGO OPTION PER CN-134355	BY: SRL
PROJECT: ST B1		TITLE: SHOP; ST-3130, 126X2016-5.9/192X3072-3.9	
DATE: 4 JUN 21	DIM UNITS: INCHES [MILLIMETERS]	SHEET	REV 02
SCALE: 1/50	DO NOT SCALE DRAWING		
DESIGN: MCARSRU	JOB NO. P2307	FUNC - TYPE - SIZE E - 10 - B	4879042
DRAWN: RBJERKE			

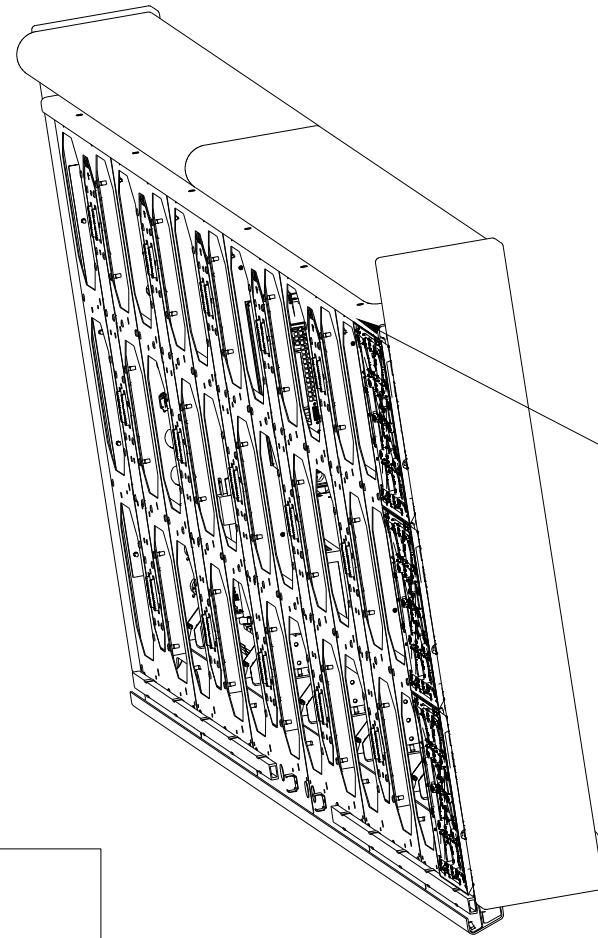

ATTACH CLIPS AND LIGHT STRIPS PER DETAIL A.

REAR VIEW

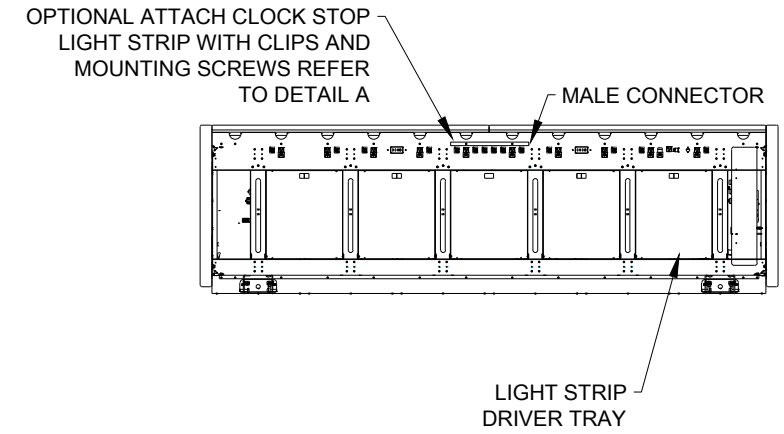

DETAIL A

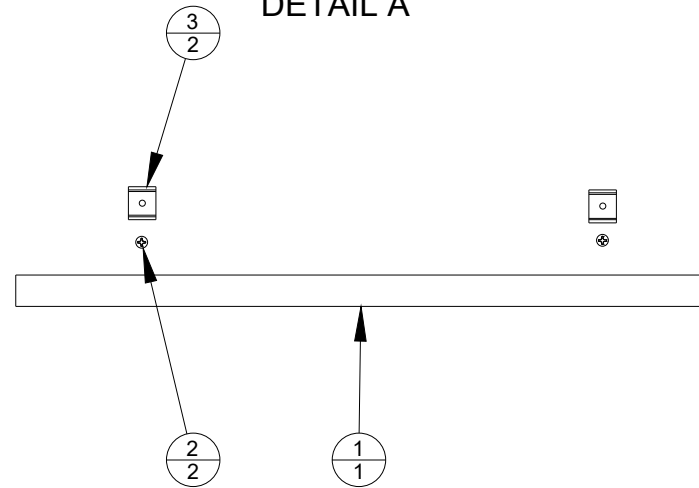

P2307_LIGHT_STRIP_ATT			
INDE X	NAME	QT Y	DESCRIPTION
1	REFER TO BOM		GEN 2, STRIP LIGHTING, LED, BLAZE X, 18IN, RED, 24V, IN ONLY
2	HC-1302		TAP SCR, #6-20 X 0.750, PHIL FLAT HEADM BLK
3	HS-3763489		CHROMAPATH SLIM BLACK U-CLIP PAIR

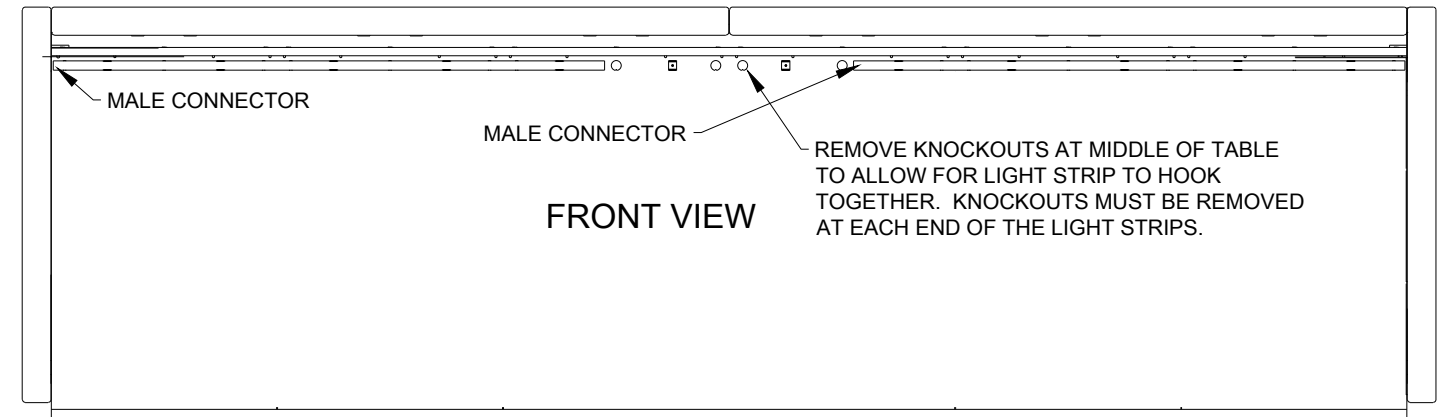

LIGHT STRIP CNTRL MOUNT TO TABLE USING HC-1554 @4 AND HC-1243 @4 (5 IN-LBS)

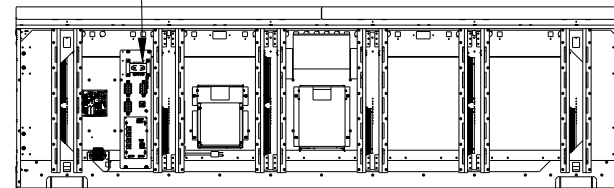

FRONT VIEW

REV	DATE	DESCRIPTION	BY:
03	16 MAR 23	CN156041 CHANGED LIGHT STRIP PART NUMBER TO REFER TO BOM ADDED TOP LOCATION AS OPTION LOCATION TO INSTALL LIGHT STRIPS	JSF
02	28 JAN 22	CN-133848 UPDATED LIGHT STRIP MOUNTING SCREW	JSF
01	AUG 30 21	CN126606 ADDED NOTE FOR WHICH SIDE OF LIGHT STRIP HAS MALE AND FEMALE ENDS	JSF

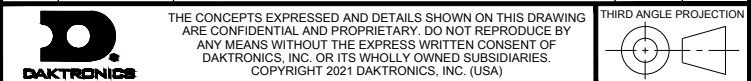

PROJECT: ST-31XY			
TITLE: LIGHT STRIP ATTACHMENT			
DATE: 23 JUN 21	DIM UNITS: INCHES [MILLIMETERS]	SHEET	REV 03
SCALE: NTS DO NOT SCALE DRAWING			
DESIGN: JFIXSEN	JOB NO. P2307	FUNC - TYPE - SIZE R - 01 - B	4889870
DRAWN: JFIXSEN			

This page intentionally left blank.

B Daktronics Warranty and Limitation of Liability

This section includes the **Daktronics Warranty & Limitation of Liability (SL-02374)**.

This page intentionally left blank.

DAKTRONICS WARRANTY & LIMITATION OF LIABILITY

This Warranty and Limitation of Liability (the "Warranty") sets forth the warranty provided by Daktronics with respect to the Equipment. By accepting delivery of the Equipment, Purchaser and End User agree to be bound by and accept these terms and conditions. Unless otherwise defined herein, all terms within the Warranty shall have the same meaning and definition as provided elsewhere in the Agreement.

DAKTRONICS WILL ONLY BE OBLIGATED TO HONOR THE WARRANTY SET FORTH IN THESE TERMS AND CONDITIONS UPON RECEIPT OF FULL PAYMENT FOR THE EQUIPMENT

1. Warranty Coverage.

- A. Daktronics warrants to the original end user (the "End User", which may also be the Purchaser) that the Equipment will be free from Defects (as defined below) in materials and workmanship for a period of one (1) year (the "Warranty Period"). The Warranty Period shall commence on the earlier of: (i) four weeks from the date that the Equipment leaves Daktronics' facility; or (ii) Substantial Completion as defined herein. The Warranty Period shall expire on the first anniversary of the commencement date.

"Substantial Completion" means the operational availability of the Equipment to the End User in accordance with the Equipment's specifications, without regard to punch-list items, or other non-substantial items which do not affect the operation of the Equipment

- B. Daktronics' obligation under this Warranty is limited to, at Daktronics' option, replacing or repairing, any Equipment or part thereof that is found by Daktronics not to conform to the Equipment's specifications. Unless otherwise directed by Daktronics, any defective part or component shall be returned to Daktronics for repair or replacement. This Warranty does not include on-site labor charges to remove or install these components. Daktronics may, at its option, provide on-site warranty service. Daktronics shall have a reasonable period of time to make such replacements or repairs and all labor associated therewith shall be performed during regular working hours. Regular working hours are Monday through Friday between 8:00 a.m. and 5:00 p.m. at the location where labor is performed, excluding any holidays observed by Daktronics.
- C. Daktronics shall pay ground transportation charges for the return of any defective component of the Equipment. All such items shall be shipped by End User DDP Daktronics designated facility per Incoterms® 2020. If returned Equipment is repaired or replaced under the terms of this Warranty, Daktronics will prepay ground transportation charges back to End User and shall ship such items DDP End User's designated facility per Incoterms® 2020; otherwise, End User shall pay transportation charges to return the Equipment back to the End User and such Equipment shall be shipped Ex Works Daktronics designated facility per Incoterms® 2020. All returns must be pre-approved by Daktronics before shipment. Daktronics shall not be obligated to pay freight for any unapproved return. End User shall pay any upgraded or expedited transportation charges
- D. Any replacement parts or Equipment will be new or serviceably used, comparable in function and performance to the original part or Equipment and warranted for the remainder of the Warranty Period. Purchasing additional parts or Equipment from the Seller does not extend the Warranty Period.
- E. Defects shall be defined as follows. With regard to the Equipment (excepting LEDs), a "Defect" shall refer to a material variance from the design specifications that prohibit the Equipment from operating for its intended use. With respect to LEDs, "Defects" are defined as LED pixels that cease to emit light. Unless otherwise expressly provided, this Warranty does not impose any duty or liability upon Daktronics for partial LED pixel degradation. Notwithstanding the foregoing, in no event does this Warranty include LED pixel degradation caused by UV light. This Warranty does not provide for the replacement or installation of communication methods including but not limited to, wire, fiber optic cable, conduit, trenching, or for the purpose of overcoming local site interference radio equipment substitutions.

EXCEPT AS OTHERWISE EXPRESSLY SET FORTH IN THIS WARRANTY, TO THE MAXIMUM EXTENT PERMITTED BY APPLICABLE LAW, DAKTRONICS DISCLAIMS ANY AND ALL OTHER PROMISES, REPRESENTATIONS AND WARRANTIES APPLICABLE TO THE EQUIPMENT AND REPLACES ALL OTHER WARRANTIES OR CONDITIONS, EXPRESS OR IMPLIED, INCLUDING, BUT NOT LIMITED TO, ANY IMPLIED WARRANTIES OR CONDITIONS OF MERCHANTABILITY, FITNESS FOR A PARTICULAR PURPOSE, OR ACCURACY OR QUALITY OF DATA. OTHER ORAL OR WRITTEN INFORMATION OR ADVICE GIVEN BY DAKTRONICS, ITS AGENTS OR EMPLOYEES, SHALL NOT CREATE A WARRANTY OR IN ANY WAY INCREASE THE SCOPE OF THIS LIMITED WARRANTY.

THIS LIMITED WARRANTY IS NOT TRANSFERABLE.

2. Exclusion from Warranty Coverage

This Warranty does not impose any duty or liability upon Daktronics for any:

- A. damage occurring at any time, during shipment of Equipment unless otherwise provided for in the Agreement. When returning Equipment to Daktronics for repair or replacement, End User assumes all risk of loss or damage, agrees to use any shipping containers that might be provided by Daktronics, and to ship the Equipment in the manner prescribed by Daktronics;
- B. damage caused by: (i) the improper handling, installation, adjustment, use, repair, or service of the Equipment, or (ii) any physical damage which includes, but is not limited to, missing, broken, or cracked components resulting from non-electrical causes;



DAKTRONICS WARRANTY & LIMITATION OF LIABILITY

altered, scratched, or fractured electronic traces; missing or gauged solder pads; cuts or clipped wires; crushed, cracked, punctured, or bent circuit boards; or tampering with any electronic connections, provided that such damage is not caused by personnel of Daktronics or its authorized repair agents;

- C. damage caused by the failure to provide a continuously suitable environment, including, but not limited to: (i) neglect or misuse; (ii) improper power including, without limitation, a failure or sudden surge of electrical power; (iii) improper air conditioning, humidity control, or other environmental conditions outside of the Equipment's technical specifications such as extreme temperatures, corrosives and metallic pollutants; or (iv) any other cause other than ordinary use;
- D. damage caused by fire, flood, earthquake, water, wind, lightning or other natural disaster, strike, inability to obtain materials or utilities, war, terrorism, civil disturbance, or any other cause beyond Daktronics' reasonable control;
- E. failure to adjust, repair or replace any item of Equipment if it would be impractical for Daktronics personnel to do so because of connection of the Equipment by mechanical or electrical means to another device not supplied by Daktronics, or the existence of general environmental conditions at the site that pose a danger to Daktronics personnel;
- F. statements made about the product by any salesperson, dealer, distributor or agent, unless such statements are in a written document signed by an officer of Daktronics. Such statements as are not included in a signed writing do not constitute warranties, shall not be relied upon by End User and are not part of the contract of sale;
- G. damage arising from the use of Daktronics products in any application other than the commercial and industrial applications for which they are intended, unless, upon request, such use is specifically approved in writing by Daktronics;
- H. replenishment of spare parts. In the event the Equipment was purchased with a spare parts package, the parties acknowledge and agree that the spare parts package is designed to exhaust over the life of the Equipment, and as such, the replenishment of the spare parts package is not included in the scope of this Warranty;
- I. security or functionality of the End User's network or systems, or anti-virus software updates;
- J. performance of preventive maintenance;
- K. third-party systems and other ancillary equipment, including without limitation front-end video control systems, audio systems, video processors and players, HVAC equipment, batteries and LCD screens;
- L. incorporation of accessories, attachments, software or other devices not furnished by Daktronics; or
- M. paint or refinishing the Equipment or furnishing material for this purpose.

3. Limitation of Liability

- A. Daktronics shall be under no obligation to furnish continued service under this Warranty if alterations are made to the Equipment without the prior written approval of Daktronics.
- B. It is specifically agreed that the price of the Equipment is based upon the following limitation of liability. In no event shall Daktronics (including its subsidiaries, affiliates, officers, directors, employees, or agents) be liable for any claims asserting or based on (a) loss of use of the facility or equipment; lost business, revenues, or profits; loss of goodwill; failure or increased cost of operations; loss, damage or corruption of data; loss resulting from system or service failure, malfunction, incompatibility, or breaches in system security; or (b) any special, consequential, incidental or exemplary damages arising out of or in any way connected with the Equipment or otherwise, including but not limited to damages for lost profits, cost of substitute or replacement equipment, down time, injury to property or any damages or sums paid to third parties, even if Daktronics has been advised of the possibility of such damages. The foregoing limitation of liability shall apply whether any claim is based upon principles of contract, tort or statutory duty, principles of indemnity or contribution, or otherwise
- C. In no event shall Daktronics be liable for loss, damage, or injury of any kind or nature arising out of or in connection with this Warranty in excess of the Purchase Price of the Equipment. The End User's remedy in any dispute under this Warranty shall be ultimately limited to the Purchase Price of the Equipment to the extent the Purchase Price has been paid.

4. Assignment of Rights

- A. The Warranty contained herein extends only to the End User (which may be the Purchaser) of the Equipment and no attempt to extend the Warranty to any subsequent user-transferee of the Equipment shall be valid or enforceable without the express written consent of Daktronics.

5. Governing Law; Election of Remedies

- A. The rights and obligations of the parties under this Warranty shall not be governed by the provisions of the United Nations Convention on Contracts for the International Sales of Goods of 1980. The parties consent to the application of the laws of the State of South Dakota to govern, interpret, and enforce each of the parties' rights, duties, and obligations arising from, or relating in any manner to, the subject matter of this Warranty, without regard to conflict of law principles.
- B. Any dispute, controversy or claim arising from or related to this Warranty, the parties shall first attempt to settle through negotiations. In the event that no resolution is reached, then such dispute, controversy, or claim shall be resolved by final and binding arbitration under the Rules of Arbitration of the International Chamber of Commerce. The language of the arbitration



DAKTRONICS WARRANTY & LIMITATION OF LIABILITY

shall be English. The place of the arbitration shall be Sioux Falls, SD. A single arbitrator selected by the parties shall preside over the proceeding. If a single arbitrator cannot be agreed upon by the parties, each party shall select an arbitrator, and those arbitrators shall confer and agree on the appointed arbitrator to adjudicate the arbitration. The arbitrator shall have the power to grant any provisional or final remedy or relief that it deems appropriate, including conservatory measures and an award of attorneys' fees. The arbitrator shall make its decisions in accordance with applicable law. By agreeing to arbitration, the Parties do not intend to deprive any court of its jurisdiction to issue a pre-arbitral injunction, pre-arbitral attachment, or other order in aid of arbitration proceedings and the enforcement of any award. Without prejudice to such provisional remedies as may be available under the jurisdiction of a court, the arbitrator shall have full authority to grant provisional remedies and to direct the Parties to request that any court modify or vacate any temporary or preliminary relief issued by such court, and to award damages for the failure of any Party to respect the arbitrator's orders to that effect.

6. Availability of Extended Service Agreement

- A. For End User's protection, in addition to that afforded by the warranties set forth herein, End User may purchase extended warranty services to cover the Equipment. The Extended Service Agreement, available from Daktronics, provides for electronic parts repair and/or on-site labor for an extended period from the date of expiration of this warranty. Alternatively, an Extended Service Agreement may be purchased in conjunction with this Warranty for extended additional services. For further information, contact Daktronics Customer Service at 1-800-DAKTRONics (1-800-325-8766).

Additional Terms applicable to sales outside of the United States

The following additional terms apply **only** where the installation site of the Equipment is located outside of the United States of America.

1. In the event that the installation site of the Equipment is in a country other than the U.S.A., then, notwithstanding Section 5 of the Warranty, where the selling entity is the entity listed in Column 1, then the governing law of this Warranty is the law of the jurisdiction listed in the corresponding row in Column 2 without regard to its conflict of law principles. Furthermore, if the selling entity is an entity listed in Column 1, then the place of arbitration is listed in the corresponding row in Column 3.

Column 1 (Selling Entity)	Column 2 (Governing Law)	Column 3 (Location of Arbitration)
Daktronics, Inc.	The state of Illinois	Chicago, IL, U.S.A.
Daktronics Canada, Inc.	The Province of Ontario, Canada	Toronto, Ontario, Canada
Daktronics UK Ltd.	England and Wales	Bristol, UK
Daktronics GmbH	The Federal Republic of Germany	Wiesbaden, Germany
Daktronics Hong Kong Limited	Hong Kong, Special Administrative Region of the P.R.C.	Hong Kong SAR
Daktronics Shanghai Co., Ltd.	The Peoples Republic of China	Shanghai, P.R.C.
Daktronics France, SARL	France	Paris, France
Daktronics Japan, Inc.	Japan	Tokyo, Japan
Daktronics International Limited	Macau, Special Administrative Region of the P.R.C.	Macau SAR
Daktronics Australia Pad Ltd	Australia	Sydney, Australia
Daktronics Singapore Pte. Ltd	Singapore	Singapore
Daktronics Brazil LTDA	Brazil	São Paulo, Brazil
Daktronics Spain S.L.U.	Spain	Madrid, Spain
Daktronics Belgium N. V	Belgium	Kruikeke, Belgium
Daktronics Ireland Co. Ltd.	Ireland	Dublin, Ireland

This page intentionally left blank.