

**HORN START HS-200**

OWNER'S MANUAL

P1056

ED-12935  
Rev 17  
17 March 2021

## FCC Statement

### Supplier Declaration of Conformity (SDoC)

This product complies with Part 15 of the FCC Rules. Operation is subject to the following two conditions: (1) This device may not cause harmful interference, and (2) this device must accept any interference received, including interference that may cause undesired operation.

**Note:** This equipment has been tested and found to comply with the limits for a Class A digital device, pursuant to part 15 of the FCC Rules. These limits are designed to provide reasonable protection against harmful interference when the equipment is operated in a commercial environment. This equipment generates, uses, and can radiate radio frequency energy and, if not installed and used in accordance with the instruction manual, may cause harmful interference to radio communications. Operation of this equipment in a residential area is likely to cause harmful interference in which case the user will be required to correct the interference at their own expense.

**Warning:** The user is cautioned that changes and modifications made to the equipment without the approval of manufacturer could void the user's authority to operate this equipment.

## Industry Canada Regulatory Information

This Class A digital apparatus complies with Canadian ICES-003.

Cet appareil numérique de la classe A est conforme à la norme NMB-003 du Canada.

## Inquiries

Contact Daktronics with any questions regarding our product compliance.

### Mail:

Daktronics  
201 Daktronics Dr.  
Brookings, SD 57006 USA

### Phone:

800-325-8766

### Website:

[www.daktronics.com](http://www.daktronics.com)



**DAKTRONICS**

### Copyright © 2007-2021

All rights reserved. While every precaution has been taken in the preparation of this manual, the publisher assumes no responsibility for errors or omissions. No part of this book covered by the copyrights hereon may be reproduced or copied in any form or by any means—graphic, electronic, or mechanical, including photocopying, taping, or information storage and retrieval systems—without written permission of the publisher.

*Daktronics trademarks are property of Daktronics, Inc. All other trademarks are property of their respective companies.*

# Table of Contents

<b>1</b>	<b>Introduction</b>	<b>1</b>
	Important Safety Instructions	1
	Regulatory Certifications	2
	Specifications Label	2
	Resources	2
	Horn Start Overview	3
<b>2</b>	<b>System Setup &amp; Operations</b>	<b>4</b>
	HS-200 Indicators, Switches, Knobs & Connections	4
	Start System Setup	5
	Connecting the Horn Start	7
	Operations	7
	Battery Operation	8
	Horn Start Settings	8
	<b>Enable or Disable Recall</b>	<b>8</b>
	<b>Configure Start Sound</b>	<b>9</b>
	<b>Enable or Disable Smart Start</b>	<b>9</b>
	<b>Enable Practice Mode</b>	<b>10</b>
	Equipment Storage	10
	Using the Horn Start	10
	<b>Before Each Session</b>	<b>10</b>
	<b>During Competition</b>	<b>10</b>
	<b>After the Competition</b>	<b>10</b>
<b>3</b>	<b>Accessories</b>	<b>11</b>
	Backstroke Flagpole Bracket	11
	<b>Attaching the Horn Start to Flagpole</b>	<b>11</b>
	Remote Strobe	11
	<b>Mounting Bracket &amp; Strap</b>	<b>11</b>
	<b>Battery Operation</b>	<b>11</b>
	<b>AC Power Operation &amp; Recharging</b>	<b>12</b>
	<b>Remote Strobe for Training Purposes</b>	<b>12</b>
	Wireless Microphone	12
	<b>Using the Wireless Microphone</b>	<b>13</b>
	<b>Set Channel Button</b>	<b>13</b>
	<b>Wireless Belt Pack Batteries</b>	<b>13</b>
	<b>Changing Belt Packs</b>	<b>14</b>
	<b>HS-200R Internal Radio Module General Operation</b>	<b>14</b>
	Set Channel Button	14
	Paired LED	14
	Data LED	14
	<b>Multiple HS-200R Units</b>	<b>14</b>
<b>4</b>	<b>Troubleshooting</b>	<b>15</b>
	Troubleshooting Tips	15

# Table of Contents

Aux or Lane speaker is not working .....	15
The microphone is not working .....	15
The strobe light does not work .....	15
Microphone works but the horn start will not Start/Strobe .....	15
The recall tone does not sound .....	15
The HS-200/HS-200R will not run with battery power .....	15
Replacement Parts.....	16
HS-200 Equipment (0A-1056-0116).....	16
HS-200R Equipment (0A-1056-0136).....	16
Optional Equipment .....	16
<b>5 Daktronics Exchange and Repair &amp; Return Programs .....</b>	<b>17</b>
Exchange Program .....	17
Repair & Return Program.....	18
Daktronics Warranty & Limitation of Liability .....	18
<b>A Reference Drawings .....</b>	<b>19</b>
<b>B Daktronics Warranty &amp; Limitation of Liability .....</b>	<b>23</b>

# 1 Introduction

## Important Safety Instructions

- Read and understand all instructions before using.
- Do not drop the horn start or immerse it in water.
- This device may be used outdoors temporarily, but it is not to be permanently mounted outdoors or left in wet weather.
- This device shall not be exposed to dripping or splashing, and no objects filled with liquid shall be placed upon it.

**WARNING!** To reduce the risk of fire or electric shock, do not expose this device to rain or moisture.

- Operate the horn start system with the built-in rechargeable battery. A completely charged battery will provide at least 15 hours of operation. Use 120 V power only when the battery's power is low.

**CAUTION!** DANGER OF EXPLOSION IF BATTERY IS INCORRECTLY REPLACED. REPLACE ONLY WITH THE SAME OR EQUIVALENT TYPE. MUST BE REPLACED BY QUALIFIED TECHNICIAN. CONTACT DAKTRONICS.

**WARNING!** Do not expose batteries to excessive heat, such as direct sunlight or fire.

- Do not run the horn start's battery dead. Charge it for 24 hours before putting the horn start away for the next meet.
- Do not let the power cord touch hot surfaces or hang over the edge of a table, which could damage or cut the cord.
- If an extension cord is necessary, use a three-pronged polarized cord. Arrange the cord with care so that no one will trip over or pull it out.
- Before using an extension cord, inspect the cable thoroughly and verify its compliance with the local electric codes.
- Always turn off and unplug the control equipment when it is not in use.
- Never yank the power cord to pull the plug from the outlet. Grasp the plug and pull to disconnect.
- To avoid electrical shock, do not disassemble the control equipment or the driver modules. Incorrect reassembly can cause electric shock and faulty operation or permanent damage to the circuits.

**WARNING!** To prevent injury, the horn start, all speakers, and remote strobe must be securely attached to a pole/wall/start block in accordance with installation instructions.

## Regulatory Certifications

HS-200 Model: DAKT-0401-00 system is certified to UL 62368-1, CSA C22.2 #62368.

HS-200 system consists of the following optional accessories:

Item Name	Manufacturer/Trademark	Model/Part Number
Auxiliary Speaker	4J	440-8
Lane Speakers	4J	306-45-54
Microphone	Astatic	636L
Belt Back Transmitter	Daktronics	0A-1056-0301 (2.4 GHz)
Remote Strobe	Daktronics	0A-1056-0126
Backstroke Flagpole Bracket	Daktronics	0M-148539 R5 (Horn Start)
		0M-157392 R2 (Remote Strobe)
Flagpole Clamp	Yakima Products	8820112

## Specifications Label

Power specifications as well as serial and model number information can be found on the device's ID label, similar to those shown in **Figure 1**.

When calling Daktronics customer service, please have the model number, serial number, and the date the device became operational available to ensure the request is serviced as quickly as possible.

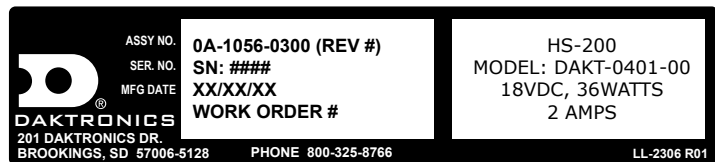

**Figure 1:** Specifications Labels

## Resources

**Figure 2** illustrates a Daktronics drawing label. This manual refers to drawings by listing the last set of digits. In the example, the drawing would be referred to as **DWG-1007804**. All references to drawing numbers, appendices, figures, or other manuals are presented in bold typeface. Any drawings referenced in a particular section are listed at the beginning of it as shown below:

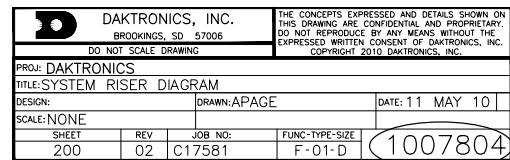

Drawing Number

**Figure 2:** Drawing Label

### Reference Drawings:

System Riser Diagram ..... **DWG-1007804**

Daktronics identifies manuals by the DD or ED number located on the cover page.

## Horn Start Overview

Every heat in swimming has a start. The rule book states, "The starter should be on a separate system that is designed specifically to provide clear and simultaneous instructions at each of the starting platforms." In addition to needing something to start each heat, many teams train for starts during practice.

A typical beginning of a race starts with the referee or assistant referee getting the athletes' attention, then turning control of them over to the start official. The start official instructs the competitors to "Step-up" for a forward start, or "Place your feet" for a backstroke start. The competitors should step into place without excessive noise or movement. The start official may give brief instructions as deemed necessary. Then, the start official commands, "Take your mark." Each swimmer, with no unnecessary noise or movement, immediately assumes the desired starting position. Once the start official sees that the swimmers have taken their position uniformly and are motionless, the signal is given to start the race. The purpose of this is to insure that no competitor has an unfair advantage by intimidation, position, jump or delay.

Daktronics has developed a start system that ensures reliability and fair starts for all. Its straightforward design produces a loud sound, bright visual strobe and precise electronic signal. The HS-200 is a portable unit that comes standard with an internal rechargeable battery, power pack, 360° strobe, 30' (9.1 m) start cable, 15' (4.6 m) microphone cable and microphone. Several other options are available, including the backstroke flagpole-mounting bracket, auxiliary speakers, individual lane speakers, wireless microphone, remote strobe and start cables to connect to other brands of timing systems, including CTS, Omega, and IST.

## 2 System Setup & Operations

### HS-200 Indicators, Switches, Knobs & Connections

The connection panel of the HS-200 horn start (**Figure 3**) is where all connection, adjustments, and status indicators are located.

1. The group of four LEDs stacked vertically on the upper left corner performs two functions. Their main function is the one for which they are labeled. The LEDs are also used to indicate the firmware revision during power-up and to also designate when the unit is in programming mode. Refer to **Operations (p.7)**.

- **ON-READY** LED indicates when the HS-200 horn start is ready to start the next race, in recall mode, or not ready.
- **CHARGING** LED indicates when the horn start is connected to main power and charging the battery.
- **BATTERY FULL** LED will be on if the power switch is turned on, and the battery is completely charged.
- **BATTERY LOW** LED will be on if the power switch is turn ON, and the battery is low.

2. The **MAIN/AUX VOLUME** control knob sets the volume of the internal speaker built into the HS-200 horn start plus the volume of the speaker plugged into the jacks labeled **AUX SPEAKER**.

3. The **LANE VOLUME** control knob sets the volume of the speakers plugged into the jacks labeled **LANE SPEAKERS**.

4. The **POWER** connection is for a universal 12 VAC power pack.

5. **ON/OFF** switch is the main power switch. Turn switch to **OFF** when the device is not being used.

6. The **MIC** jack is a standard CB style 4-pin cobra/uniden microphone connector. A microphone extension can be used if it does not exceed 50' (15 m).

7. The **AUX SPEAKER** jacks typically connect to the Auxiliary Speaker cable. If there are no lane speakers, plug the Aux Speaker cable into the **LANE SPEAKER** jacks. This will give separate volume control of the Aux Speaker and the internal speaker on the horn start in addition to each of them having their own dedicated amplifier.

8. The **LANE SPEAKERS** jacks typically connect to the cable from the Lane Speakers.

9. **START** and **N/C** jacks connect to the timing console start input. The black jack is the GND tab that the start cable plugs into.

The **START** jack output is a Normally Open switch contact, meaning the switch output is open and closes momentarily to signal the start of the race. The **N/C** jack output is a Normally Closed switch contact, meaning the switch output is closed and opens momentarily to signal the start of the race.

10. These controls and indicators are for the wireless microphone. Refer to **Wireless Microphone (p.12)** for more information on wireless microphone setup.



**Figure 3:** HS-200 Connection Panel



# Start System Setup

## Reference Drawings:

HS-200 Horn Start; On-Deck configuration..... **DWG-185695**

Refer to **Figure 4** (In-Deck) and **Figure 5** (On-Deck) for a typical overview when placing the start system components.

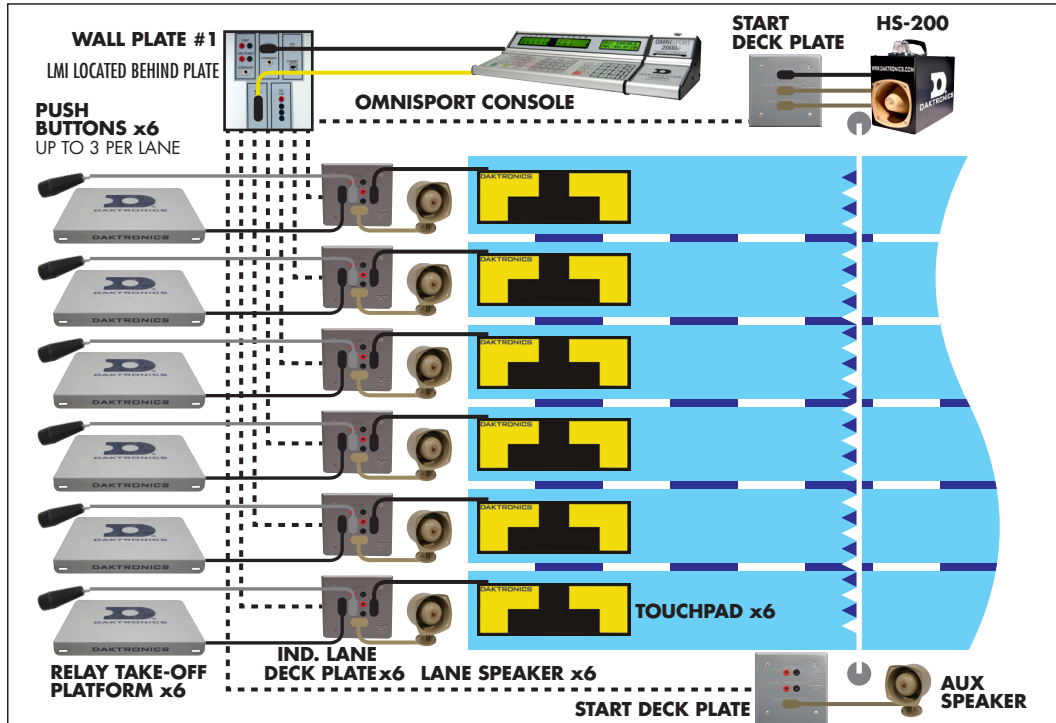

Figure 4: Typical In-Deck Swimming Installation

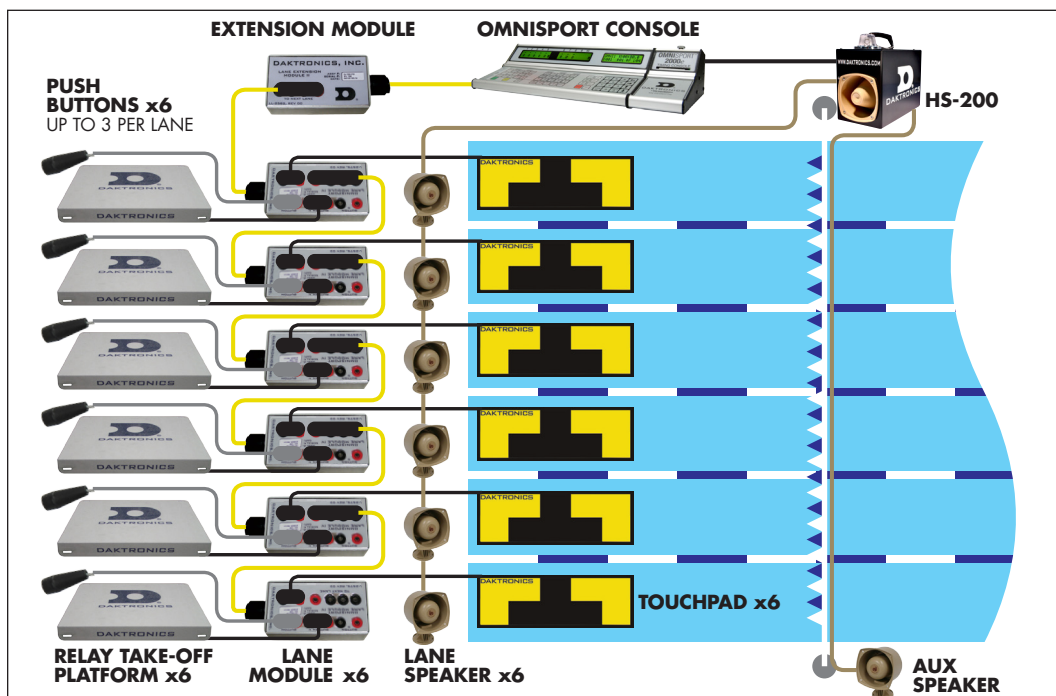

Figure 5: Typical On-Deck Swimming Installation

The start system components are shown in **Figure 6 – Figure 9**. For specific part numbers and options available, refer to **DWG-185695** in **Appendix A**.



**Figure 6:** HS-200 with Mic



**Figure 7:** Horn Start with Internal Speaker



**Figure 8:** Backstroke Flagpole Speaker

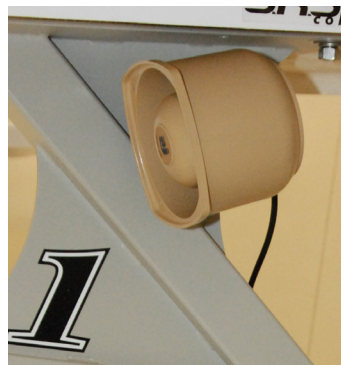

**Figure 9:** Lane Speaker

**Notes:**

- Install the speakers tilting down to easily drain and prevent water from collecting inside.
- Always place cables and equipment in areas of minimal traffic. Cover wires and cables with a mat to prevent accidents.

When plugging in dual banana connectors (**Figure 10**), the **GND (ground) tab on the plug must line up with the black female jack for the timing system to work**. Remember this when connecting all dual banana plugs.



**Figure 10:** Insert GND Side to Black Female Jack

## Connecting the Horn Start

- Connect the cable from the lane speakers into the jacks labeled **LANE SPEAKERS** on the HS-200 connection panels.
- Connect the cable from the Auxiliary speaker (Backstroke speaker) into the jacks labeled **AUX SPEAKER** on the HS-200.
- Connect the cable from the OmniSport 2000 start input **J12** into the jacks labeled **START** on the HS-200.

**Note:** Correct connections are crucial for the horn start to properly function. Improper plugging may cause damage to the equipment!

- If using the HS-200 horn start with an Omega® timing console, connect the start cable from the Omega console to the **N/C** connectors on the HS-200.
- If using the HS-200 horn start with a Colorado Timing System console, connect the start cable from the CTS console to the **START** connectors on the HS-200.
- Connect the microphone cable into the jack labeled **MIC** on the HS-200.
- Connect a wallpack power supply from the **POWER** jack to a 120 VAC outlet.

For complete information on Daktronics timing system setup, refer to **Section 2** of the **OmniSport 2000 Timing Console Operations Manual (ED-13312)**, available online at [www.daktronics.com/manuals](http://www.daktronics.com/manuals).

## Operations

After installation is complete, turn on the power to the unit. Set the volume controls to the desired levels for the main/auxiliary and lane speakers by adjusting the volume control knobs along the left side of the unit.

Press and hold the **PUSH TO TALK** lever (the large button on the side of the microphone) with your left thumb, hold the mic a few inches away from your mouth, and speak directly into it. When not speaking into the microphone, release the **PUSH TO TALK** lever (**Figure 11**).

To activate the horn start system, depress and hold the **PUSH TO TALK** lever on the side of the microphone with your left thumb. While maintaining the pressure on the lever, momentarily depress the small button on the top of the microphone with your index finger. After the start tone has sounded, release both buttons.



**Figure 11:** Microphone Buttons

After a race has been started, the **RECALL** LED flashes for 18 seconds. During this time, the horn start is in the recall mode. To sound the recall signal, depress the **PUSH TO TALK** lever on the side of the microphone and the small button on top of the microphone simultaneously. The recall signal can be muted. If the recall signal does not sound, or if it sounds when it is not supposed to, refer to **Section 4: Troubleshooting (p.15)**.

## Battery Operation

With a full charge, the HS-200 battery can provide up to 15 hours of continuous operation. When not in use, plug the HS-200 wallpack power supply (Daktronics part # A-3430138) into a 120 VAC outlet to recharge the internal battery. The internal circuitry monitors the charging process, so leaving the HS-200 horn start plugged in and charging for extended periods does not damage the internal battery. Also, do not run the battery dead.

The **ON/OFF** switch on the HS-200 system does NOT need to be turned on to charge the internal battery. The battery charging circuitry will be active whenever the HS-200 wallpack power supply is plugged into the wall outlet.

When the power supply is plugged in, the **CHARGING** LED will give the battery-charging status (**Figure 12**). If the **CHARGING** LED is off (or flashing) and the **BATTERY FULL** LED is on, the battery is fully charged.

When the HS-200 system is being powered by the battery and is not plugged into the wall, the **BATTERY FULL** and **BATTERY LOW** LEDs show battery status. The green **BATTERY FULL** LED indicates when the battery voltage level is fine for operation. The red **BATTERY LOW** LED indicates the battery voltage level is half drained and should be charged soon. Should the red **BATTERY LOW** LED begin flashing, the HS-200 unit has 10 minutes of battery power remaining and will automatically shut down after this period has expired. At this time, the horn start should be charged immediately. Once the charger is connected to a 120 VAC outlet, the HS-200 system will operate normally.

For information about possible problems with battery charging, refer to **Section 4: Troubleshooting (p.15)**.

## Horn Start Settings

### Enable or Disable Recall

1. Plug the handheld microphone directly into the **MIC** jack on the HS-200.
2. To access the setup mode, turn the power switch to **ON**. Immediately after the **BATTERY FULL** and **BATTERY LOW** LEDs flash, press the **PUSH TO TALK** lever three times.
3. The four LED indicators on the horn start will flash and the speaker will sound a warbling tone when the Recall On setting is active. If that setting is not active, then no sound will come from the speaker and the four LED indicators will flash.
4. To change the setting, press the **PUSH TO TALK** button once. This will enable or disable the setting.
5. To save the current setting, press and hold the **PUSH TO TALK** button while pressing the top button twice. The LEDs should stop flashing. The HS-200 horn start is now configured for the selected recall setting.

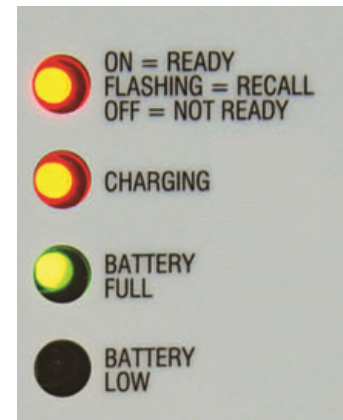

**Figure 12:** Battery Charging

## Configure Start Sound

Select between two different swimming tones or a gun shot.

1. Plug the handheld microphone directly into the **MIC** jack on the HS-200.
2. To access the setup mode, turn the power switch to **ON**. Immediately after the **BATTERY FULL** and **BATTERY LOW** LEDs flash, press the **PUSH TO TALK** lever four times.
3. The four LED indicators on the horn start will flash and the speaker will sound the current setting. This sound will be either the tone or the gunshot.
4. To change the setting, press the **PUSH TO TALK** button. Every time that button is pushed, it will move to a different setting.
5. To save the current setting, press and hold the **PUSH TO TALK** button while pressing the top button twice. The LEDs should stop flashing.

## Enable or Disable Smart Start

The HS-200 horn start can detect a connection from the timer console. If the horn start is connected to an OmniSport 2000 timing console, the Smart Start will sense the timer via the dual banana plug extension cable plugged into the **START** or **N/C** input.

When activated as described below, the Smart Start feature will allow normal use of the horn start microphone but will not allow a Start tone and Strobe activation unless the HS-200 is connected to the timing console and the console is ready for the next race. Should the timing console not have a ready status feature, then the Smart Start will function based on cable connection only.

If a timing console is ready and properly connected, the **READY/RECALL** LED will be on and not flashing. It will take a couple of seconds to initialize. If no timing console is present and/or the cable connecting the HS-200 and console is damaged, unplugged, or plugged in backwards (black into red), the **READY/RECALL** LED will be OFF.

To enable or disable Smart Start:

1. Plug the handheld microphone directly into the **MIC** jack on the HS-200 horn start.
2. To access the setup mode, turn the power switch to **ON**. Immediately after the **BATTERY FULL** and **BATTERY LOW** LEDs flash, press the **PUSH TO TALK** lever five times.
3. The three lower LED indicators on the horn start will flash. The **READY/RECALL** LED will either be ON or OFF.
4. To change the setting, press the **PUSH TO TALK** button once. The **READY/RECALL** LED will change to ON or OFF.
  - If the **READY/RECALL** LED is ON, the Smart Start is activated.
  - If the **READY/RECALL** LED is OFF, the Smart Start is deactivated (default).
5. To save the current setting, press and hold the **PUSH TO TALK** button while pressing the top button twice. The LEDs should stop flashing. The HS-200 is now configured with the Smart Start setting.



## Enable Practice Mode

Practice Mode changes the delay time between consecutive starts to three seconds between beeps compared to the default delay time of eighteen seconds. Cycling the power on the horn start will deactivate Practice Mode.

When in Practice Mode, the strobe will not flash until after ten seconds have elapsed between strobes. Also, the Smart Start feature is disabled while in Practice Mode.

**It is NOT recommended that Practice Mode be used for timed competitions.**

1. Plug the handheld microphone directly into the **MIC** jack on the HS-200.
2. Turn the power switch on and immediately press and hold both the **PUSH TO TALK** and top buttons.
3. The horn start speaker will sound off a Start tone. The HS-200 horn start is now in Practice Mode.
4. Cycling the power switch of the HS-200 to will set the horn start back to normal.

## Equipment Storage

The HS-200 unit and speakers should be stored in a cool, dry place, away from the pool environment. Coil and store all cables away from the pool.

The charging circuit is designed so the battery can be charged for extended periods; however, it is not required that the HS-200 horn start be connected to the wall outlet during the off-season. Before storage, plug the HS-200 horn start into the wall outlet for 24 hours to fully charge the battery. Allow 24 hours of recharge time after the HS-200 horn start has been taken out of storage as well. It is important to ensure the horn start's battery is not drained.

## Using the Horn Start

### Before Each Session

Follow these basic steps when preparing for a meet:

1. Connect the fully-charged equipment.
2. Verify that all speakers are working.
3. Test the microphone and set volume levels.
4. Test the start signal to the timing system.
5. Verify the strobe light flashes for a start.
6. Verify the HS-200 Horn Start is set to start tone. Refer to **Horn Start Settings (p.8)**.
7. Verify the recall signal is ON or OFF as desired. Refer to **Horn Start Settings (p.8)**.
8. Verify Smart Start is ON or OFF as desired. Refer to **Horn Start Settings (p.8)**.

### During Competition

Before starting the next heat, verify the start LED is **ON-READY**.

### After the Competition

1. Remember to recharge the battery for 24 hours.
2. Turn the power switch to **OFF**.
3. Store the horn start in a clean, dry place.

### 3 Accessories

This section describes optional accessories that are available with the HS-200 horn start.

#### Backstroke Flagpole Bracket

The Backstroke Flagpole Bracket (**Figure 13**) allows the horn start to be mounted to the backstroke flagpole. When pool deck space is limited, this eliminates the clutter of a podium or tripod on the deck and the possibility of the unit being knocked into the pool. The backstroke flagpole is also a good position for the horn start because sound is distributed evenly across the lanes.



Figure 13: Flagpole Bracket

#### Attaching the Horn Start to Flagpole

1. Use a #2 Phillips screwdriver to remove top-middle screw and the two right-rear screws identified in **Figure 14**.
2. Mount the backstroke flagpole bracket as illustrated in **Figure 15**.
3. Re-install the three screws removed in **Step 1**.
4. Use both locking straps to securely fasten the unit to the flagpole.



Figure 14: Remove Screws

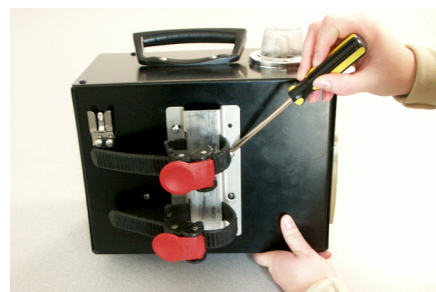

Figure 15: Attach Bracket

#### Remote Strobe

##### Mounting Bracket & Strap

A mounting bracket and strap are included with the remote strobe for mounting to a backstroke flagpole or to a start block. The remote strobe also has rubber feet for setting on any flat surface.

##### Battery Operation

The HS-200 remote strobe includes an internal 12 VDC battery that provides up to 15 hours of continuous use. Using the remote strobe on battery power requires one end of a start extension cable with the dual banana plug to be plugged into the **UNIVERSAL START INPUT** (**Figure 16**).



Figure 16: Remote Strobe

The other end of the cable should plug into either the **START** or **N/C** jack on the HS-200. If the HS-200 is also connected to the OmniSport timer, the remote strobe cable will piggyback onto the timer output cable. Use the **START** output when using Daktronics or CTS timers. Use **N/C** when using Omega timers.

The remote strobe turns on automatically when it receives a start signal from the start unit. The green **PWR ON** LED will light and the internal buzzer will sound.

The remote strobe requires a 15-second period between start signals to produce a flash. Any start signal received within 15 seconds of the previous start signal will sound the internal buzzer but may not flash the strobe. To simulate a start with a backup push button, connect the button into the start input and press the button until the remote strobe flashes.

In order to conserve battery life, the remote strobe will turn itself off after one hour with no use. To turn the strobe back on, connect it to the starting device and send a start signal. Multiple start signals may be needed in order to charge the strobe. Apply start signals until the strobe flashes.

When the internal battery reaches a low level, the red **BATTERY LOW** LED will light for approximately 30 seconds and the remote strobe will turn off. Any start signal received after the internal battery is low will light the **BATTERY LOW** LED momentarily.

## AC Power Operation & Recharging

**Note:** For safety reasons, when using the remote strobe near water, use battery power for device operation to minimize the risk of electrical shock.

The HS-200 remote strobe operates the same way whether using AC power or battery power. The remote strobe includes a circuit that will recharge the internal battery when the wallpack power supply is connected to a 120 VAC outlet. When the remote strobe is connected to AC power, the green **PWR ON** LED lights up and the strobe is ready for use. The internal battery will recharge in approximately three to four hours. Due to internal battery monitoring circuitry, the remote strobe can be plugged into the wall for extended periods without overcharging. The amber **BAT CHRG** LED is illuminated when the internal battery is being charged.

## Remote Strobe for Training Purposes

To use the remote strobe during training sessions, instead of connecting it to the HS-200 start unit, a backup push button can be connected into the start input. When the backup push button is pressed, the remote strobe will operate the same way it did when connected to the start unit.

## Wireless Microphone

The HS-200R wireless microphone is an accessory that allows the starter to direct and start events without a wired connection to the horn start unit. The HS-200R system is equipped with an internal radio module. A standard HS-200 system can be retrofitted with an internal radio module to use a wireless microphone. With the wireless microphone option, two microphones can be used; one wireless and one wired as a backup.

The same handheld microphone that plugs into the HS-200 directly (or via microphone extension cords) is used with the wireless microphone belt pack. For operation of the handheld microphone, refer to **Operations (p.7)**.



## Using the Wireless Microphone

1. Turn on the HS-200 unit using the **ON/OFF** switch. Note the **CHANNEL** number.
2. Turn on the wireless microphone unit by pressing the **SET CHANNEL** button once. A blinking dot will appear to verify it is powered on.
3. Press the **SET CHANNEL** button again to view the channel number. If it does not match the number noted in step 1, press the **SET CHANNEL** button until they are the same.
4. With matching channel numbers, the dot will continue to blink while it attempts to connect. Once connected, the dot disappears, and the **PAIRED** LED on the HS-200 unit lights up.
5. Plug the handheld microphone into the wireless unit. Clip the wireless unit to belt, and hang the microphone by the lanyard from neck as demonstrated in **Figure 17**.
6. Press the side push-to-talk lever and speak into the microphone. The **DATA** LED on the HS-200 unit should light up. To send a start signal, hold the side push-to-talk lever and press the top button.
7. To power down the wireless unit, either press and hold the **SET CHANNEL** button until a "P" appears, or remove the batteries. Note that the unit also automatically powers off 2 minutes after the HS-200 unit has been turned off to conserve battery life.



**Figure 17:** Wireless Unit & Microphone

## Set Channel Button

The wireless microphone belt pack and the HS-200R unit both include a **SET CHANNEL** button to select the radio channel used for the start signal. Pressing the **SET CHANNEL** button once on the wireless microphone belt pack shows the current transmit channel on the **CHANNEL #** display. Pressing the button while the channel number is displayed moves to the next channel. As with the wireless microphone belt pack, pressing the **SET CHANNEL** button on the HS-200R unit changes the current radio channel; the current channel is always shown on the **CHANNEL** display. Channels 0-7 are available for use.

Once both the wireless microphone belt pack and HS-200R unit are set to the same channel, they should find each other and connect within 30 seconds. After two seconds, the channel number on the wireless microphone belt pack will turn off to save power, but the decimal point will continue to blink while attempting to connect. Once a successful connection is made, the decimal point will stop blinking, and the **PAIRED** LED on the HS-200R unit will light up and stay lit.

The wireless microphone belt pack will attempt to connect to an HS-200R for one minute. If a connection is not found, it will automatically power down.

If the HS-200R is turned off, the wireless microphone belt pack **CHANNEL #** display will start flashing again, indicating no connection. As noted above, it will look for a connection for one minute before powering down.

## Wireless Belt Pack Batteries

The wireless microphone belt pack uses two AA batteries for operation (included). To replace the batteries, remove the cover on the back of the wireless microphone belt pack. Always keep spare batteries on hand for each meet.

The wireless microphone belt pack operates for approximately 10 hours under meet conditions on one set of high quality alkaline batteries (3125 mAHr capacity). The batteries should be removed after every meet to prevent damage from battery acid leakage. Properly dispose any dead batteries.

The **CHANNEL #** display shows an "L" when the batteries are low. If "L" appears when the **PUSH TO TALK** lever is pressed, replace the batteries in the unit as soon as possible.

## Changing Belt Packs

1. Turn off belt pack #1 by either pressing and holding the **SET CHANNEL** button until a "P" appears on the **CHANNEL #** display, or removing the batteries.
2. Turn on belt pack #2 by pressing the **SET CHANNEL** button.
3. Press the **SET CHANNEL** button until it matches the channel shown on the HS-200R unit.

Alternately, Press the **SET CHANNEL** button on the HS-200R unit to break the connection to belt pack #1, and then turn on and set belt pack #2 to the new channel.

## HS-200R Internal Radio Module General Operation

### Set Channel Button

Press the **SET CHANNEL** button on the HS-200R unit to change the current channel. This channel will also need to be selected on the wireless microphone belt pack.

### Paired LED

The **PAIRED** LED on the HS-200R unit lights up when a successful connection has been made to a wireless microphone belt pack set to the same channel, and it will stay on as long as the connection is active.

### Data LED

The **DATA** LED on the HS-200R unit illuminates when a valid radio transmission has been received from the wireless microphone. This LED should be on whenever the microphone **PUSH TO TALK** lever is pressed.

## Multiple HS-200R Units

If it is necessary to use more than one HS-200R unit in the same facility – or within 900' (275 m) of each other – simply set both wireless systems to different channels.

**Note:** A single belt pack CANNOT operate multiple horn starts; a separate wireless belt pack is required to control each HS-200 unit.

## 4 Troubleshooting

This section gives detailed information about troubleshooting some of the situations that the HS-200/HS-200R system operator may experience. If the actions listed in this section are unable to be performed or do not solve a particular issue, contact a local representative or Daktronics Customer Service Department for assistance.

### Troubleshooting Tips

#### Aux or Lane speaker is not working

Connect the correct speaker directly to the appropriate HS-200/HS-200R jack without any extension cables. If the speaker still does not work, the speaker is faulty and must be replaced. If the speaker begins to work, the cable that connects to that speaker is at fault and must be repaired or replaced.

#### The microphone is not working

Make sure the power is on and that the volume controls are up high enough to be heard. Press the microphone **PUSH TO TALK** lever and **Start/Recall** buttons simultaneously to attempt a start. Disconnect and reconnect the microphone to ensure a good connection. If there is a microphone extension cable being used, unplug it and the plug the microphone into the horn start directly. If either the start function or microphone still does not work, the microphone must be replaced.

#### The strobe light does not work

Make sure the **READY/RECALL** LED is lit and steady. If the **BATTERY LOW** LED is on, plug the HS-200/HS-200R into the wall outlet and retry. Send up to 4-6 start signals into the remote strobe. The capacitor must be energized first to work properly. If it still does not work, the strobe light must be replaced.

#### Microphone works but the horn start will not Start/Strobe

Ensure that the horn start Smart Start setting is set to the desired mode of operation as described in **Enable or Disable Smart Start (p.9)**. If the Smart Start is enabled, ensure that the horn start unit is properly connected to a timing console such as an OmniSport 2000 controller, and that the cable is not damaged. Alternately, turn off Smart Start.

#### The recall tone does not sound

Verify the recall function is enabled on the HS-200/HS-200R unit. Refer to **Enable or Disable Recall (p.8)**.

#### The HS-200/HS-200R will not run with battery power

If the **CHARGING** LED is off and the **BATTERY LOW** LED is lit, the battery may no longer work or may have been severely damaged due to long periods of usage when the battery was underpowered. Plug the horn start into the wall outlet for 24 hours. If the same problem occurs, the unit should be sent into Daktronics to have the battery replaced.

## Replacement Parts

### HS-200 Equipment (0A-1056-0116)

Description	Part Number
Microphone extension, 15' (4.5 m)	0A-1056-0122
Handheld dual switch microphone with coiled cord	0A-1056-0173
HS-200 horn start unit	0A-1056-0234
Wallpack power supply	A-3430138
OmniSport timer output cable, 30' (9.1 m)	W-1425

### HS-200R Equipment (0A-1056-0136)

Description	Part Number
Microphone extension, 15' (4.5 m)	0A-1056-0122
Wireless microphone belt pack	0A-1056-0301
Handheld dual switch microphone with coiled cord	0A-1056-0173
HS-200R horn start unit	0A-1056-0300
Wallpack power supply	A-3430138
OmniSport timer output cable, 30' (9.1 m)	W-1425

### Optional Equipment

Description	Part Number
Speaker Extension Cord 10' (3 m)	0A-1056-0081
Microphone Extension 50' (15 m)	0A-1056-0123
Remote Strobe with buzzer	0A-1056-0126
Flag Pole Mounting Bracket, HS-200	0A-1056-0129
HS-200 Wireless Microphone Retrofit Kit	0A-1056-0238
Speaker Extension Cord 125' (38 m)	0A-1056-0154
Speaker Extension Cord 200' (61 m)	0A-1056-0165
Cable; 30' (9.1 m) Adapter for Horn Start to Lynx	0A-1125-0001
Start Extension on Reel 500' (152 m)	0A-1125-0003
Backstroke Flag Pole Speaker with Mounting Bracket	0F-1056-0030
Speaker Extension Cord 30' (9.1 m)	0F-1056-0047
Tripod Stand, Requires Flag Pole Mounting Bracket (not included)	A-1580
Lane Speaker	DS-1059
Starter Extension Cable; 10' (3 m)	W-1426
Starter Extension Cable; 125' (38 m)	W-1517
Starter Extension Cable; 200' (61 m)	W-1518

Refer to **Section 5: Daktronics Exchange and Repair & Return Programs (p.17)** for information on exchanging or returning parts.

## 5 Daktronics Exchange and Repair & Return Programs

### Exchange Program

The Daktronics Exchange Program is a service for quickly replacing key components in need of repair. If a component fails, Daktronics sends a replacement part to the customer who, in turn, returns the failed component to Daktronics. This decreases equipment downtime. Customers who follow the program guidelines explained below will receive this service.

Before contacting Daktronics, identify these important numbers:

**Serial Number:** \_\_\_\_\_

**Model Number:** \_\_\_\_\_

**Job/Contract Number:** \_\_\_\_\_

**Date Manufactured/Installed:** \_\_\_\_\_

**Daktronics Customer ID Number:** \_\_\_\_\_

To participate in the Exchange Program, follow these steps:

**1. Call Daktronics Customer Service.**

United States & Canada: 1-800-DAK-TRON (325-8766)

Outside the U.S. & Canada: +1-605-275-1040

**2. When the new exchange part is received, mail the old part to Daktronics.**

If the replacement part fixes the problem, send in the problem part being replaced.

- a. Package the old part in the same shipping materials in which the replacement part arrived.
- b. Fill out and attach the enclosed UPS shipping document.
- c. Ship the part to Daktronics.

**3. The defective or unused parts must be returned to Daktronics within 5 weeks of initial order shipment.**

If any part is not returned within five (5) weeks, a non-refundable invoice will be presented to the customer for the costs of replenishing the exchange parts inventory with a new part. Daktronics reserves the right to refuse parts that have been damaged due to acts of nature or causes other than normal wear and tear.

## Repair & Return Program

For items not subject to exchange, Daktronics offers a Repair & Return Program. To send a part for repair, follow these steps:

**1. Call Daktronics Customer Service.**

United States & Canada: 1-800-DAK-TRON (325-8766)

Outside the U.S. & Canada: +1-605-275-1040

**2. Receive a case number before shipping.**

This expedites repair of the part.

**3. Package and pad the item carefully to prevent damage during shipment.**

Electronic components, such as printed circuit boards, should be placed in an antistatic bag before boxing. Daktronics does not recommend using packing peanuts when shipping.

**4. Enclose:**

- name
- address
- phone number
- the case number
- a clear description of symptoms

**5. Ship to:**

Daktronics Customer Service

[Case #]

201 Daktronics Drive, Dock E

Brookings, SD 57006

## Daktronics Warranty & Limitation of Liability

The Daktronics Warranty & Limitation of Liability is located at the end of this manual. The Warranty is independent of Extended Service agreements and is the authority in matters of service, repair, and display operation.

# A Reference Drawings

Refer to **Resources (p.2)** for information regarding how to read the drawing number. Any contract-specific drawings take precedence over the general drawings.

**Reference Drawings:**

HS-200 Horn Start; On-Deck Configuration ..... **DWG-185695**

*This page intentionally left blank.*



REAR VIEW

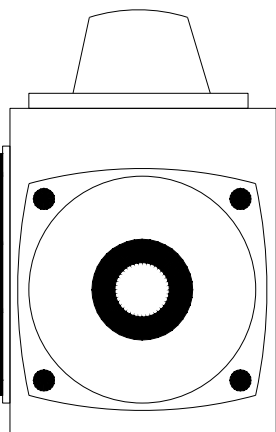

OA-1056-0129  
FLAG POLE MTC.  
BRACKET

HS-200 HORN START,  
OA-1056-0234  
  
WIRELESS HORN START  
OA-1056-0235 (900 MHz)  
OA-1056-0300 (2.4 GHz)

FRONT VIEW

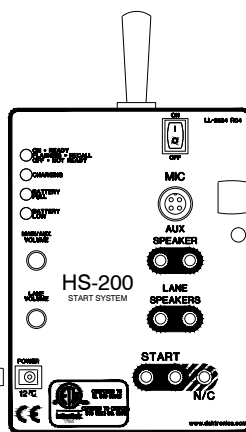

POWER SUPPLY  
A-3430138

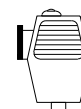

MICROPHONE  
OA-1056-0173

MIC. EXTENSION CORD  
OA-1056-0122, 15'  
OA-1056-0123, 50'  
(OPTIONAL)

HS-200 PACKAGES ARE THE FOLLOWING:  
OA-1056-0116 - HS-200 /W ACCESSORIES.  
INCLUDES: HS-200, 6' MIC, 15' MIC EXT., PWR TRANS.,  
30' START CABLE.

OA-1056-0136 - HS-200 WIRELESS /W ACCESSORIES.  
INCLUDES: HS-200 WIRELESS, 6' MIC, WIRELESS BELT  
PACK, 15' MIC EXT., PWR TRANS., 30' START CABLE.

OPTIONAL RADIO

HORN START,  
WIRELESS SHOWN

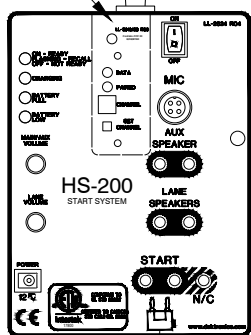

CABLE ASSEMBLIES  
W-1426, 10'  
W-1425, 30'  
W-1517, 125'  
W-1518, 200'  
OA-1125-0003, 500'

MOUNTING STRAP

AUXILIARY SPEAKER,  
OF-1056-0030.

SPEAKER EXTENSION CORDS  
OA-1056-0081, 10'  
OF-1056-0047, 30'  
OA-1056-0154, 125'  
OA-1056-0165, 200'

INDIVIDUAL LANE  
SPEAKERS (10 MAX  
PER HS-200),  
DS-1059  
TYPICAL @ 1 PER LANE

MICROPHONE  
OA-1056-0173  
BELT PACK TRANSMITTER  
OA-1056-0134 (900 MHz)  
OA-1056-0301 (2.4 GHz)

SPEAKER EXTENSION CORD  
OA-1056-0081, 10'  
TYPICAL @ 1 PER LANE

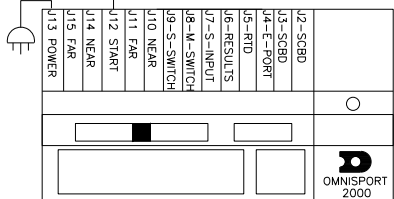

REV 04	DATE: 12 APR 17	UPDATED OA NUMBERS AND ADDED OA-1056-0300 ASSEMBLY TO WIRELESS HORN START	BY: RDF
REV	DATE:		BY:

**DAKTRONICS** THE CONCEPTS EXPRESSED AND DETAILS SHOWN ON THIS DRAWING ARE CONFIDENTIAL AND PROPRIETARY. DO NOT REPRODUCE BY ANY MEANS WITHOUT THE EXPRESS WRITTEN CONSENT OF DAKTRONICS, INC. OR ITS WHOLLY OWNED SUBSIDIARIES. COPYRIGHT 2017 DAKTRONICS, INC. (USA)

THIRD ANGLE PROJECTION

PROJECT: OMNISPORT			
TITLE: HS-200 HORN START: ON-DECK CONFIGURATION			
DATE: 23 APR 03	DIM UNITS: INCHES [MILLIMETERS]	SHEET	REV 04
SCALE: NONE		DO NOT SCALE DRAWING	
DESIGN: MMILLER	JOB NO. P1056	FUNC - TYPE - SIZE R-01-A	185695
DRAWN: MMILLER			

*This page intentionally left blank.*

## **B Daktronics Warranty & Limitation of Liability**

This section includes the Daktronics Warranty & Limitation of Liability statement (SL-02374).

*This page intentionally left blank.*

# DAKTRONICS WARRANTY & LIMITATION OF LIABILITY

This Warranty and Limitation of Liability (the "Warranty") sets forth the warranty provided by Daktronics with respect to the Equipment. By accepting delivery of the Equipment, Purchaser and End User agree to be bound by and accept these terms and conditions. Unless otherwise defined herein, all terms within the Warranty shall have the same meaning and definition as provided elsewhere in the Agreement.

DAKTRONICS WILL ONLY BE OBLIGATED TO HONOR THE WARRANTY SET FORTH IN THESE TERMS AND CONDITIONS UPON RECEIPT OF FULL PAYMENT FOR THE EQUIPMENT

## 1. Warranty Coverage.

- A. Daktronics warrants to the original end user (the "End User", which may also be the Purchaser) that the Equipment will be free from Defects (as defined below) in materials and workmanship for a period of one (1) year (the "Warranty Period"). The Warranty Period shall commence on the earlier of: (i) four weeks from the date that the Equipment leaves Daktronics' facility; or (ii) Substantial Completion as defined herein. The Warranty Period shall expire on the first anniversary of the commencement date.  
  
"Substantial Completion" means the operational availability of the Equipment to the End User in accordance with the Equipment's specifications, without regard to punch-list items, or other non-substantial items which do not affect the operation of the Equipment
- B. Daktronics' obligation under this Warranty is limited to, at Daktronics' option, replacing or repairing, any Equipment or part thereof that is found by Daktronics not to conform to the Equipment's specifications. Unless otherwise directed by Daktronics, any defective part or component shall be returned to Daktronics for repair or replacement. This Warranty does not include on-site labor charges to remove or install these components. Daktronics may, at its option, provide on-site warranty service. Daktronics shall have a reasonable period of time to make such replacements or repairs and all labor associated therewith shall be performed during regular working hours. Regular working hours are Monday through Friday between 8:00 a.m. and 5:00 p.m. at the location where labor is performed, excluding any holidays observed by Daktronics.
- C. Daktronics shall pay ground transportation charges for the return of any defective component of the Equipment. All such items shall be shipped by End User DDP Daktronics designated facility per Incoterms® 2020. If returned Equipment is repaired or replaced under the terms of this Warranty, Daktronics will prepay ground transportation charges back to End User and shall ship such items DDP End User's designated facility per Incoterms® 2020; otherwise, End User shall pay transportation charges to return the Equipment back to the End User and such Equipment shall be shipped Ex Works Daktronics designated facility per Incoterms® 2020. All returns must be pre-approved by Daktronics before shipment. Daktronics shall not be obligated to pay freight for any unapproved return. End User shall pay any upgraded or expedited transportation charges
- D. Any replacement parts or Equipment will be new or serviceably used, comparable in function and performance to the original part or Equipment and warranted for the remainder of the Warranty Period. Purchasing additional parts or Equipment from the Seller does not extend the Warranty Period.
- E. Defects shall be defined as follows. With regard to the Equipment (excepting LEDs), a "Defect" shall refer to a material variance from the design specifications that prohibit the Equipment from operating for its intended use. With respect to LEDs, "Defects" are defined as LED pixels that cease to emit light. Unless otherwise expressly provided, this Warranty does not impose any duty or liability upon Daktronics for partial LED pixel degradation. Notwithstanding the foregoing, in no event does this Warranty include LED pixel degradation caused by UV light. This Warranty does not provide for the replacement or installation of communication methods including but not limited to, wire, fiber optic cable, conduit, trenching, or for the purpose of overcoming local site interference radio equipment substitutions.

EXCEPT AS OTHERWISE EXPRESSLY SET FORTH IN THIS WARRANTY, TO THE MAXIMUM EXTENT PERMITTED BY APPLICABLE LAW, DAKTRONICS DISCLAIMS ANY AND ALL OTHER PROMISES, REPRESENTATIONS AND WARRANTIES APPLICABLE TO THE EQUIPMENT AND REPLACES ALL OTHER WARRANTIES OR CONDITIONS, EXPRESS OR IMPLIED, INCLUDING, BUT NOT LIMITED TO, ANY IMPLIED WARRANTIES OR CONDITIONS OF MERCHANTABILITY, FITNESS FOR A PARTICULAR PURPOSE, OR ACCURACY OR QUALITY OF DATA. OTHER ORAL OR WRITTEN INFORMATION OR ADVICE GIVEN BY DAKTRONICS, ITS AGENTS OR EMPLOYEES, SHALL NOT CREATE A WARRANTY OR IN ANY WAY INCREASE THE SCOPE OF THIS LIMITED WARRANTY.

THIS LIMITED WARRANTY IS NOT TRANSFERABLE.

## 2. Exclusion from Warranty Coverage

This Warranty does not impose any duty or liability upon Daktronics for any:

- A. damage occurring at any time, during shipment of Equipment unless otherwise provided for in the Agreement. When returning Equipment to Daktronics for repair or replacement, End User assumes all risk of loss or damage, agrees to use any shipping containers that might be provided by Daktronics, and to ship the Equipment in the manner prescribed by Daktronics;
- B. damage caused by: (i) the improper handling, installation, adjustment, use, repair, or service of the Equipment, or (ii) any physical damage which includes, but is not limited to, missing, broken, or cracked components resulting from non-electrical causes;



# DAKTRONICS WARRANTY & LIMITATION OF LIABILITY

altered, scratched, or fractured electronic traces; missing or gauged solder pads; cuts or clipped wires; crushed, cracked, punctured, or bent circuit boards; or tampering with any electronic connections, provided that such damage is not caused by personnel of Daktronics or its authorized repair agents;

- C. damage caused by the failure to provide a continuously suitable environment, including, but not limited to: (i) neglect or misuse; (ii) improper power including, without limitation, a failure or sudden surge of electrical power; (iii) improper air conditioning, humidity control, or other environmental conditions outside of the Equipment's technical specifications such as extreme temperatures, corrosives and metallic pollutants; or (iv) any other cause other than ordinary use;
- D. damage caused by fire, flood, earthquake, water, wind, lightning or other natural disaster, strike, inability to obtain materials or utilities, war, terrorism, civil disturbance, or any other cause beyond Daktronics' reasonable control;
- E. failure to adjust, repair or replace any item of Equipment if it would be impractical for Daktronics personnel to do so because of connection of the Equipment by mechanical or electrical means to another device not supplied by Daktronics, or the existence of general environmental conditions at the site that pose a danger to Daktronics personnel;
- F. statements made about the product by any salesperson, dealer, distributor or agent, unless such statements are in a written document signed by an officer of Daktronics. Such statements as are not included in a signed writing do not constitute warranties, shall not be relied upon by End User and are not part of the contract of sale;
- G. damage arising from the use of Daktronics products in any application other than the commercial and industrial applications for which they are intended, unless, upon request, such use is specifically approved in writing by Daktronics;
- H. replenishment of spare parts. In the event the Equipment was purchased with a spare parts package, the parties acknowledge and agree that the spare parts package is designed to exhaust over the life of the Equipment, and as such, the replenishment of the spare parts package is not included in the scope of this Warranty;
- I. security or functionality of the End User's network or systems, or anti-virus software updates;
- J. performance of preventive maintenance;
- K. third-party systems and other ancillary equipment, including without limitation front-end video control systems, audio systems, video processors and players, HVAC equipment, batteries and LCD screens;
- L. incorporation of accessories, attachments, software or other devices not furnished by Daktronics; or
- M. paint or refinishing the Equipment or furnishing material for this purpose.

### 3. Limitation of Liability

- A. Daktronics shall be under no obligation to furnish continued service under this Warranty if alterations are made to the Equipment without the prior written approval of Daktronics.
- B. It is specifically agreed that the price of the Equipment is based upon the following limitation of liability. In no event shall Daktronics (including its subsidiaries, affiliates, officers, directors, employees, or agents) be liable for any claims asserting or based on (a) loss of use of the facility or equipment; lost business, revenues, or profits; loss of goodwill; failure or increased cost of operations; loss, damage or corruption of data; loss resulting from system or service failure, malfunction, incompatibility, or breaches in system security; or (b) any special, consequential, incidental or exemplary damages arising out of or in any way connected with the Equipment or otherwise, including but not limited to damages for lost profits, cost of substitute or replacement equipment, down time, injury to property or any damages or sums paid to third parties, even if Daktronics has been advised of the possibility of such damages. The foregoing limitation of liability shall apply whether any claim is based upon principles of contract, tort or statutory duty, principles of indemnity or contribution, or otherwise
- C. In no event shall Daktronics be liable for loss, damage, or injury of any kind or nature arising out of or in connection with this Warranty in excess of the Purchase Price of the Equipment. The End User's remedy in any dispute under this Warranty shall be ultimately limited to the Purchase Price of the Equipment to the extent the Purchase Price has been paid.

### 4. Assignment of Rights

- A. The Warranty contained herein extends only to the End User (which may be the Purchaser) of the Equipment and no attempt to extend the Warranty to any subsequent user-transferee of the Equipment shall be valid or enforceable without the express written consent of Daktronics.

### 5. Governing Law; Election of Remedies

- A. The rights and obligations of the parties under this Warranty shall not be governed by the provisions of the United Nations Convention on Contracts for the International Sales of Goods of 1980. The parties consent to the application of the laws of the State of South Dakota to govern, interpret, and enforce each of the parties' rights, duties, and obligations arising from, or relating in any manner to, the subject matter of this Warranty, without regard to conflict of law principles.
- B. Any dispute, controversy or claim arising from or related to this Warranty, the parties shall first attempt to settle through negotiations. In the event that no resolution is reached, then such dispute, controversy, or claim shall be resolved by final and binding arbitration under the Rules of Arbitration of the International Chamber of Commerce. The language of the arbitration

# DAKTRONICS WARRANTY & LIMITATION OF LIABILITY

shall be English. The place of the arbitration shall be Sioux Falls, SD. A single arbitrator selected by the parties shall preside over the proceeding. If a single arbitrator cannot be agreed upon by the parties, each party shall select an arbitrator, and those arbitrators shall confer and agree on the appointed arbitrator to adjudicate the arbitration. The arbitrator shall have the power to grant any provisional or final remedy or relief that it deems appropriate, including conservatory measures and an award of attorneys' fees. The arbitrator shall make its decisions in accordance with applicable law. By agreeing to arbitration, the Parties do not intend to deprive any court of its jurisdiction to issue a pre-arbitral injunction, pre-arbitral attachment, or other order in aid of arbitration proceedings and the enforcement of any award. Without prejudice to such provisional remedies as may be available under the jurisdiction of a court, the arbitrator shall have full authority to grant provisional remedies and to direct the Parties to request that any court modify or vacate any temporary or preliminary relief issued by such court, and to award damages for the failure of any Party to respect the arbitrator's orders to that effect.

## 6. Availability of Extended Service Agreement

- A. For End User's protection, in addition to that afforded by the warranties set forth herein, End User may purchase extended warranty services to cover the Equipment. The Extended Service Agreement, available from Daktronics, provides for electronic parts repair and/or on-site labor for an extended period from the date of expiration of this warranty. Alternatively, an Extended Service Agreement may be purchased in conjunction with this Warranty for extended additional services. For further information, contact Daktronics Customer Service at 1-800-DAKTRONics (1-800-325-8766).

### Additional Terms applicable to sales outside of the United States

The following additional terms apply **only** where the installation site of the Equipment is located outside of the United States of America.

1. In the event that the installation site of the Equipment is in a country other than the U.S.A., then, notwithstanding Section 5 of the Warranty, where the selling entity is the entity listed in Column 1, then the governing law of this Warranty is the law of the jurisdiction listed in the corresponding row in Column 2 without regard to its conflict of law principles. Furthermore, if the selling entity is an entity listed in Column 1, then the place of arbitration is listed in the corresponding row in Column 3.

Column 1 (Selling Entity)	Column 2 (Governing Law)	Column 3 (Location of Arbitration)
Daktronics, Inc.	The state of Illinois	Chicago, IL, U.S.A.
Daktronics Canada, Inc.	The Province of Ontario, Canada	Toronto, Ontario, Canada
Daktronics UK Ltd.	England and Wales	Bristol, UK
Daktronics GmbH	The Federal Republic of Germany	Wiesbaden, Germany
Daktronics Hong Kong Limited	Hong Kong, Special Administrative Region of the P.R.C.	Hong Kong SAR
Daktronics Shanghai Co., Ltd.	The Peoples Republic of China	Shanghai, P.R.C.
Daktronics France, SARL	France	Paris, France
Daktronics Japan, Inc.	Japan	Tokyo, Japan
Daktronics International Limited	Macau, Special Administrative Region of the P.R.C.	Macau SAR
Daktronics Australia Pad Ltd	Australia	Sydney, Australia
Daktronics Singapore Pte. Ltd	Singapore	Singapore
Daktronics Brazil LTDA	Brazil	São Paulo, Brazil
Daktronics Spain S.L.U.	Spain	Madrid, Spain
Daktronics Belgium N. V	Belgium	Kruikeke, Belgium
Daktronics Ireland Co. Ltd.	Ireland	Dublin, Ireland

*This page intentionally left blank.*