

**MULTIPURPOSE TRACK & FIELD
LED TIMING DISPLAYS**

**INSTALLATION &
OPERATION MANUAL**

P1153

ED-13768
Rev 13
09 February 2024

Models
TI-2020
TI-2021

FCC Statement

Supplier Declaration of Conformity (SDoC)

This product complies with Part 15 of the FCC Rules. Operation is subject to the following two conditions: (1) This device may not cause harmful interference, and (2) this device must accept any interference received, including interference that may cause undesired operation.

Note: This equipment has been tested and found to comply with the limits for a Class A digital device, pursuant to part 15 of the FCC Rules. These limits are designed to provide reasonable protection against harmful interference when the equipment is operated in a commercial environment. This equipment generates, uses, and can radiate radio frequency energy and, if not installed and used in accordance with the instruction manual, may cause harmful interference to radio communications. Operation of this equipment in a residential area is likely to cause harmful interference in which case the user will be required to correct the interference at their own expense.

Warning: The user is cautioned that changes and modifications made to the equipment without the approval of manufacturer could void the user's authority to operate this equipment.

Industry Canada Regulatory Information

This Class A digital apparatus complies with Canadian ICES-003.

Cet appareil numérique de la classe A est conforme à la norme NMB-003 du Canada.

Inquiries

Contact Daktronics with any questions regarding our product compliance.

Mail:

Daktronics
201 Daktronics Dr.
Brookings, SD 57006 USA

Phone:

800-325-8766

Website:

www.daktronics.com



DAKTRONICS

Copyright © 2008-2024

All rights reserved. While every precaution has been taken in the preparation of this manual, the publisher assumes no responsibility for errors or omissions. No part of this book covered by the copyrights hereon may be reproduced or copied in any form or by any means—graphic, electronic, or mechanical, including photocopying, taping, or information storage and retrieval systems—without written permission of the publisher.

Daktronics trademarks are property of Daktronics, Inc. All other trademarks are property of their respective companies.

Table of Contents

1	Introduction	1
	Important Safety Instructions.....	1
	Specifications Label.....	1
	Resources.....	2
	Daktronics Nomenclature.....	2
	Display Controllers.....	2
	Product Safety Approval.....	3
	Display Overview.....	3
	Specifications.....	3
2	Mechanical Installation	4
	Wall Mounting.....	4
	Tripod Mounting.....	5
	Mounting & Adjusting the Optional Horn.....	6
3	Electrical Installation	7
	Warnings and Disclaimers.....	7
	Power.....	7
	Grounding	7
	Portable Power Pack	8
	Signal.....	8
	Radio.....	8
4	Controls & Timing Functions	9
	Program Selection.....	9
	Program Operations.....	10
5	Display Maintenance	14
	Component Location & Access.....	14
	Replacing Digits.....	14
	Replacing Colons & Breakout Board.....	16
	LED Drivers.....	17
	Replacing a Driver	17
	Setting the Driver Address	18
	Segmentation & Digit Designation.....	18
	Schematics.....	18
	Replacement Parts.....	19
6	Daktronics Exchange and Repair & Return Programs	20
	Exchange Program.....	20
	Repair & Return Program.....	21
	Daktronics Warranty & Limitation of Liability.....	21
A	Reference Drawings	23
B	Daktronics Warranty & Limitation of Liability	35

This page intentionally left blank.

Resources

Figure 2 illustrates a Daktronics drawing label. This manual refers to drawings by listing the last set of digits. In the example, the drawing would be referred to as **DWG-1007804**. All references to drawing numbers, appendices, figures, or other manuals are presented in bold typeface. Any drawings referenced in a section are listed at the beginning of it as shown below:

 DAKTRONICS, INC. BROOKINGS, SD 57006 <small>DO NOT SCALE DRAWING</small>		<small>THE CONCEPTS EXPRESSED AND DETAILS SHOWN ON THIS DRAWING ARE CONFIDENTIAL AND PROPRIETARY. DO NOT REPRODUCE BY ANY MEANS WITHOUT THE EXPRESSED WRITTEN CONSENT OF DAKTRONICS, INC. COPYRIGHT 2010 DAKTRONICS, INC.</small>
PROJ: DAKTRONICS TITLE: SYSTEM RISER DIAGRAM DESIGN: _____ DRAWN: APAGE DATE: 11 MAY 10		
SCALE: NONE		
SHEET 200	REV 02	JOB NO: C17581
		FUNC-TYPE-SIZE F-01-D
		1007804

Drawing Number

Figure 2: Drawing Label

Reference Drawing:

System Riser Diagram **DWG-1007804**

Daktronics identifies manuals by the DD or ED number located on the cover page.

Ensure all applicable materials have been gathered before beginning the installation. Contact a Daktronics sales coordinator or project manager.

Daktronics Nomenclature

Most display components have a white label that lists the part number (**Figure 3**). Part numbers will also appear on certain drawings. If a component is not found in the **Replacement Parts (p.19)**, use the label to order a replacement. Refer to **Section 6: Daktronics Exchange and Repair & Return Programs (p.20)** if replacing or repairing any display component.

0P-1127-0024
SN: 2465 02/19/12 Rev. 1

Figure 3: Part Label

Main Component Labels	
Part Type	Part Number
Individual circuit board	0P-XXXX-XXXX
Assembly; a collection of circuit boards	0A-XXXX-XXXX
Wire or cable	W-XXXX
Fuse	F-XXXX
Transformer	T-XXXX
Metal part	0M-XXXXXXX
Fabricated metal assembly	0S-XXXXXX
Specially ordered part	PR-XXXXX-X

Accessory Labels	
Component	Label
Termination block for power or signal cable	TBXX
Grounding point	EXX
Power or signal jack	JXX
Power or signal plug for the opposite jack	PXX

Display Controllers

Daktronics outdoor timing displays are designed with an internal controller. However, they may also be controlled via an All Sport® 1600 console, an All Sport® 5000 console, or an OmniSport® 2000 timing console. All controllers use keyboard overlays (sport inserts) to control numerous sports and display models. If external control is desired, refer to the following manuals for operating instructions:

Model	Control Console Manual
TI-2020 & TI-2021	<ul style="list-style-type: none"> • All Sport 1600 Series Control Console Operation Manual (ED-12462) • OmniSport 2000 Timing Console Operations Manual (ED-13312)
TI-2021 Only	<ul style="list-style-type: none"> • All Sport 5000 Series Control Console Operation Manual (ED-11976)

Product Safety Approval

Daktronics outdoor displays are ETL listed and tested to CSA standards for outdoor use. Contact Daktronics with any questions regarding the testing procedures.

Display Overview

Models TI-2020 and TI-2021 are portable timing systems with ten programmable functions. Though external signal input can be applied, the control systems are entirely self-contained. Refer to **Section 4: Controls & Timing Functions (p.9)** for descriptions of the control capabilities.

Both TI-2020 and TI-2021 include a detachable power cord and plug into any standard 120-240 VAC receptacle. The units may also be powered with an optional battery pack.

Note: While the TI-2020 and TI-2021 are constructed for outdoor use, they cannot be left outside overnight or during inclement weather.

Specifications

This section lists the mechanical specifications, circuit specifications and maximum power requirements for each display model in this manual.

- Models with a -11 suffix feature red digits.
- Models with a -21 suffix feature amber digits.

Model	Dimensions: Height, Width, Depth	Weight	Power (120/240 V)	Driver # & Address
TI-2020	1'-2" H x 4'-8" W x 6" D (356 mm, 1422 mm, 152 mm)	50 lb (23 kg)	115 Watts, 1 Amp	A1 22
TI-2021	1'-6" H x 5'-4" W x 6" D (457 mm, 1626 mm, 152 mm)	60 lb (27 kg)		

2 Mechanical Installation

This section describes the mounting details of the TI-2020 and TI-2021. Use this section when mounting a display to a wall or on the tripod kit. Other mounting methods can be used, but Daktronics engineers do not recommend those not documented here. Daktronics is not responsible for mounting the display.

Note: Daktronics assumes no liability for any installation derived from the information provided in this manual or installations designed and installed by others.

Wall Mounting

Models TI-2020 and TI-2021 mount to a wall using an optional bracket (Daktronics part # 0M-178446). This bracket then attaches to two wall anchors. A qualified engineer must specify the anchor type according to national and local building codes.

Note: Do not attempt to permanently suspend a display by its carrying handle. Also, do not permanently mount a display outdoors or leave in wet weather.

Before beginning installation, place the short side of the bracket against the mounting surface, level it, and then mark the surface through the anchor holes on the bracket with a marker or heavy pencil. Drill holes in the wall and install anchors at the marked locations. Minimum steel anchor size is 3/8" diameter.

Note: Due to the variety of wall materials used in sports facilities, Daktronics cannot anticipate every user's installation needs or provide mounting hardware suitable for every installation. Choose a method of installation that will safely support the display's weight.

Refer to **Figure 4** for display mounting instructions.

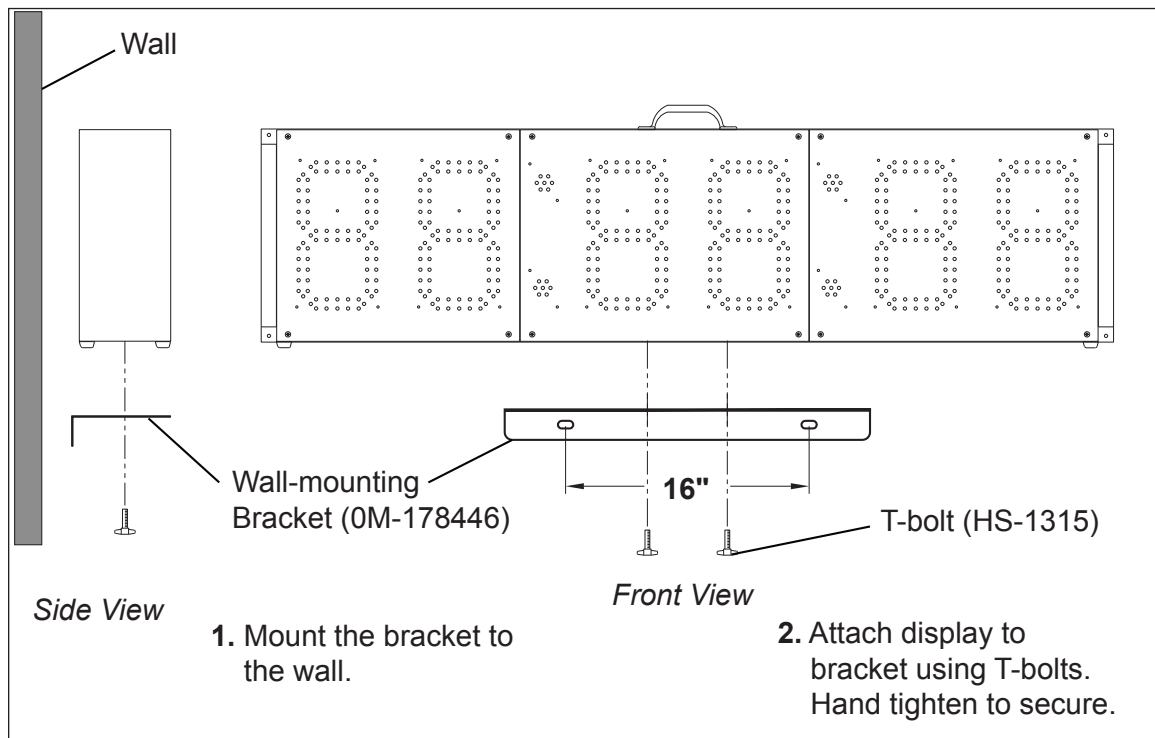

Figure 4: Wall Mounting Kit Installation

Tripod Mounting

Mounting the display to a tripod requires the optional tripod stand adapter (part # HS-1306). A camera tripod is not sturdy enough to safely support the display and will not attach to the display. An appropriate "speaker stand" tripod is available from Daktronics (part # A-1580).

The tripod stand adapter, illustrated in **Figure 5**, attaches directly to the bottom of the timing display and to the 1.5" tube of the tripod:

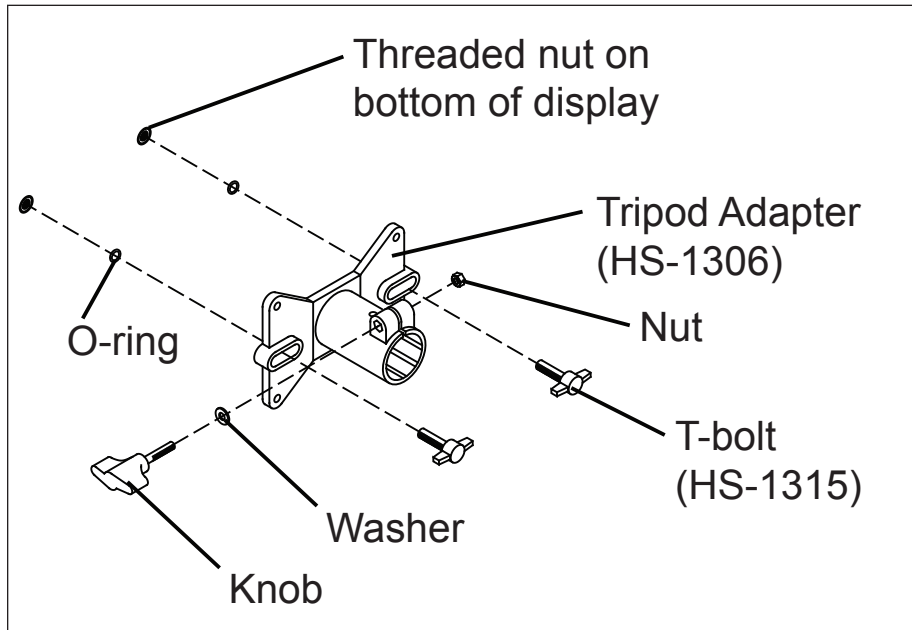

Figure 5: Tripod Adaptor

Daktronics recommends securing the stand adapter to the bottom of the display first. Two 5/16" T-bolts included with the kit thread into nuts built into the bottom of the display. Hand-tighten the T-bolts. With the adapter attached to the display cabinet, slide the adapter over the end of the stand tube and tighten the knob to secure the display to the tripod.

To level the display, loosen the knob and tilt the cabinet backward or forward as needed. Secure the knob tightly after re-positioning the display.

Mounting & Adjusting the Optional Horn

Both the TI-2020 and TI-2021 have the option of a vibrating, buzzer-type horn (part # 0A-1152-0332). The horn is attached externally to the cabinet as described below:

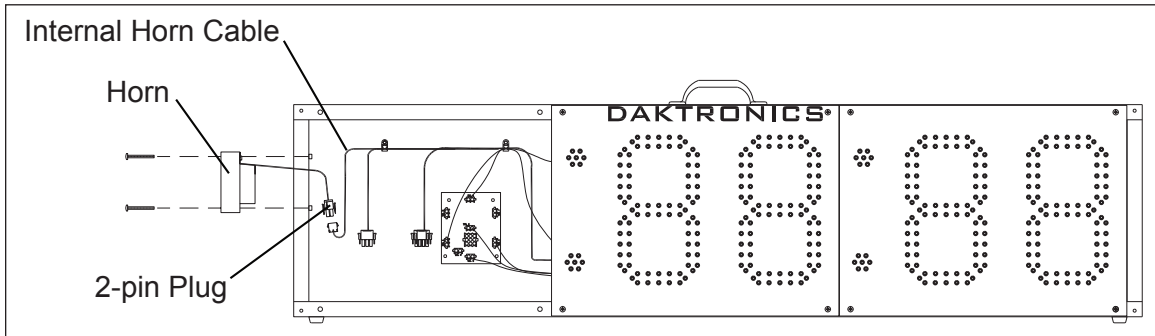

Figure 6: Horn Installation (Left Panel Removed)

1. Disconnect power to the display.
2. Remove the cover plate on the left side of the cabinet. Be sure to save the two screws, as these will be needed to attach the horn. The cover plate may be discarded.
3. Run the horn cable into the cabinet through the mounting hole, as shown in **Figure 6**. Reach through the hole and connect the horn's 2-pin plug to the mating jack. (The horn jack is on the left-most cable in the cabinet when viewed from the front; the cable is already plugged into jack **J18** on the driver).

Note: The far-left front digit faceplate may be removed for easier access to the internal horn cable.

4. Using the same screws that secured the plate, attach the horn to the cabinet.
5. Test the horn.

CAUTION: The horn is a 120 VAC device. Turn off the power to the display before adjusting the horn!

The volume for the horn is set at its maximum level at the factory. If the horn is too loud, reduce its volume by adjusting the setscrew mounted in the front of the horn. A plastic tip on the screw touches the horn's diaphragm, reducing the volume. Turn the screw clockwise and test the volume by operating the horn from the control panel. Continue adjusting and testing until the desired volume level is obtained.

Note that with the noise of spectators, the horn will not seem as loud as when it is being tested in an empty area, so be sure to set the volume according to the acoustics of the facility.

3 Electrical Installation

Electrical installation involves connecting the display to a power source and routing signal wiring from the control location (if using an All Sport or OmniSport console).

Note: Verify that all power is disconnected before working with electrical components; severe injury or damage to components could occur if the display is serviced while powered.

Warnings and Disclaimers

- Ensure that all electrical work meets or exceeds all local or national electrical codes.
- Provide the required power to the display as listed on the product labels, specifications, or site-specific riser drawings. The conductor size may vary based on the length of the power run.
- Consider implementing a separate circuit for the display using an isolation transformer or dedicated transformer.
- Daktronics assumes no liability for any issues caused by line voltage fluctuations or other improper power conditions.

Power

Reference Drawings:

Electrical Spec- TI-2020	DWG-178820
Electrical Spec- TI-2021	DWG-305729

Both TI-2020 and TI-2021 displays require a 120-240 VAC, 15 Amp circuit. Maximum power consumption is approximately 115 Watts. Each model has a detachable power cord with a three-prong plug. The power cord plugs into the **AC IN** jack on the right side of the display (viewed from the front). Install a grounded receptacle near the equipment so that the power cord can easily reach it.

The TI-2020 and TI-2021 are self-contained, that is, they function independently and may be operated without any additional device for signal transmission or control. However, the timing displays also may be used with an All Sport or OmniSport control console. In that instance, the control console also requires a 120 VAC receptacle. Like the displays, the Daktronics controllers use less than 1 Amp of power.

DWG-178820 and **DWG-305729** in **Appendix A** detail all power and signal specifications and indicate locations of internal electronic components.

Grounding

All components of a display system – including but not limited to displays, control equipment, and connected peripheral equipment – must be electrically grounded. Only qualified individuals may perform electrical work, including verification of ground resistance. Daktronics is not responsible for improper grounding or damage incurred as a result of improper grounding.

Grounding methods must meet the provisions of all applicable local and national codes. Inspect and verify all grounding methods meet the provisions of all applicable local and national codes.

Proper grounding is necessary for reliable equipment operation and general electrical safety. Failure to properly ground the display system may void the warranty, disrupt operation, damage equipment, and cause bodily harm or death.

Portable Power Pack

Reference Drawings:

Installation, Portable Powered Scoreboards..... **DWG-1039104**

For locations where a power source may be unavailable or an outdoor receptacle difficult to reach, the displays may be connected to an optional portable power pack. A portable power pack permits operation of a small display via battery power. The power pack is provided by customer and should include batteries, a charger, and a 120 VAC power inverter. Daktronics has a hookup kit available (part # 0A-1192-0349) for a customer-provided battery pack. Refer to **DWG-1039104** for installation steps.

Signal

As previously noted, models TI-2020 and TI-2021 are self-contained and require no external signal connection or controller. However, both units may be operated directly with an All Sport controller or as part of a complete Daktronics scoring/timing system. The signal information in this section applies only when an external controller is used. **DWG-178820** and **DWG-305729** in **Appendix A** illustrate the signal connections on the end panel of each display.

1. Begin signal installation by routing paired, shielded cable, 22 AWG minimum (part # W-1077) in conduit between the display location and the control location.
2. Connect the signal cable to a 1/4" phone J-box at the control end.
3. Attach a 1/4" phone plug to the display end of the cable.
4. Insert the 1/4" plug into the **SIGNAL IN** jack on the display's side panel.
5. Connect a signal cord between the control J-box and the control console.

Note: Signal installation requires no internal connections or changes.

Radio

Reference Drawings:

Assy Drawing - Radio Placement On TI-2020..... **DWG-409066**

The TI-2020 has the option of being controlled remotely via wireless radio. If a radio receiver kit is to be used, refer to **DWG-409066** in **Appendix A** for installation instructions and channel setup information. Note that this setup also requires a control console equipped with an optional radio transmitter.

4 Controls & Timing Functions

Program Selection

The TI-2020 and TI-2021 displays are programmable for ten different timing programs. The operator selects each program and makes settings for the functions using the switches on the right side of the display. **Figure 7** shows the TI-2020 control panel and programming connections (the TI-2021 control panel is similar).

To select a program:

1. Press and hold **<RESET>** for 2 seconds. The display will show PR## (program number) and then the preset time.
2. While holding **<RESET>**, press and release **<HORN>** to increment the program number by one. Program numbers are as follows:
 - 1) Cross Country Clock (with normally open Start and Stop)
 - 2) Marathon Clock (with normally open Start and Stop)
 - 3) Count Up (with normally open Start and Stop)
 - 4) Count Up (with normally closed Start and Stop)
 - 5) Game Clock
 - 6) 12-hour Time of Day
 - 7) 24-hour Time of Day
 - 8) Agility Timer (with normally open Start and Stop)
 - 9) Agility Timer (with normally closed Start and Stop)
 - 10) Self Timer (with special reset/start and normally open stop)

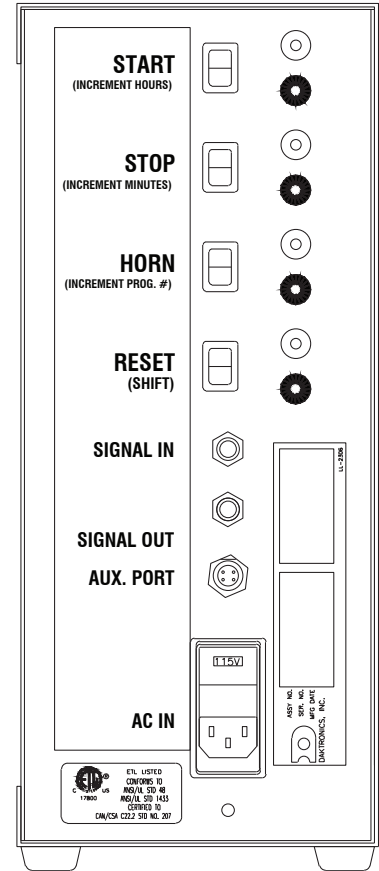

Figure 7: Control Panel (TI-2020)

Note: Refer to **Program Operations (p.10)** for more information about each program.

To modify the preset time for programs 1, 2, 3, 4, 5, 8, 9, and 10:

1. Press and hold **<RESET>** for 2 seconds. The display will show PR## (program number) and then the preset time.
2. While holding **<RESET>**, press **<START>** to increment minutes and press **<STOP>** to increment seconds.
3. Release **<RESET>** to save the time. The display will count up to or down from that time, depending on the selected program.

To set the time of day for programs 6 and 7:

1. Press and hold **<RESET>** for 2 seconds. The display will show PR## (program number) and then the preset time.
2. While holding **<RESET>**, press **<START>** to increment hours and press **<STOP>** to increment minutes.
3. Release **<RESET>** to save the Time of Day.

Program Operations

1. Cross Country Clock (with normally open Start and Stop)

This program shows the time in MN:SC.TH.

The display counts up from 0 to 99:59.99, rolls over to 0:00, and continues to count. After the initial **START** is received, additional **START** inputs will be ignored until the clock is reset to 0.00. Pressing **<STOP>** freezes the running time on the display to a hundredth (0.01) of a second. The internal clock continues counting. Pressing **<RESET>** sets the clock to 0.00. Pressing **<RESET>** again returns the clock to the current running time. The **<HORN>** input manually sounds the horn.

This mode also has the ability to program a countdown to start. Press **<RESET>** once to reset the display to 0.00. Press and hold **<RESET>**. After two seconds, PR:(current program #) will display for one second, then the countdown time will display. If 0 is showing, the display will start counting up from 0. If, for example, the number 10 is showing, the display will start counting down. While still holding **<RESET>**, toggle **<START>** to set the minutes, and toggle **<STOP>** to set the seconds.

- **START** input will look for a normally open closure.
- **STOP** input will look for a normally open closure.
- **HORN** input will look for a normally open closure.
- **RESET** input will look for a normally open closure.

2. Marathon Clock (with normally open Start and Stop)

In this mode, the display shows time in HR:MN:SC format.

The display counts up from 0 to 99:59:59, rolls over to 0:00, and continues to count. After the initial **START** is received, additional **START** inputs will be ignored until the clock is RESET to 0.00. Pressing **<STOP>** freezes the running time on the display. The internal clock continues counting. Pressing **<RESET>** sets the clock to 0.00. Pressing **<RESET>** again returns the clock to the current running time. The **<HORN>** input manually sounds the horn.

This mode also has the ability to program a countdown to start. Press **<RESET>** once to reset the display to 0.00. Press and hold **<RESET>**. After two seconds, PR:(current program #) will display for one second, then the countdown time will display. If 0 is showing, the display will start counting up from 0. If, for example, the number 10 is showing, the display will start counting down. While still holding **<RESET>**, toggle **<START>** to set the minutes, and toggle **<STOP>** to set the seconds.

- **START** input will look for a normally open closure.
- **STOP** input will look for a normally open closure.
- **HORN** input will look for a normally open closure.
- **RESET** input will look for a normally open closure.

3. Count Up (with normally open Start and Stop)

In this mode, the display is programmed to a specific time, running in MN:SC.TH format. When the display reaches the preset time, the horn sounds and the clock stops.

A setting of 0 tells the display to count up from 0 to 59:59.99, roll over to 0:00 and continue counting. If a value from 00:01 to 99:59 is set, the display starts counting at 0; it sounds the horn when the set value is reached and stops on that value. Pressing **<RESET>** sets the clock to 00.0.

During the operations described above, if the display is already counting and a **START** input is triggered, the display will show the elapsed time for 10 seconds and then go back to displaying the running time. If the display is stopped and **<START>** is pressed, the display will continue counting from the stopped time. If the **STOP** input is received fewer than 10 seconds before the **START**, the timer will display the negative value (-9.99) for 10 seconds and then go to the current running time. The **<HORN>** input manually sounds the horn.

- **START** input will look for a normally open closure.
- **STOP** input will look for a normally open closure.
- **HORN** input will look for a normally open closure.
- **RESET** input will look for a normally open closure.

4. Count Up (with normally closed Start and Stop)

In this mode, the display is programmed to a specific time, running in MN:SC.TH format. When the display reaches the preset time, the horn sounds and the clock stops.

A setting of 0 tells the display to count up from 0 to 59:59.99, roll over to 0:00, and continue counting. If a value from 00:01 to 99:59 is set, the display starts counting at 0; it sounds the horn when the set value is reached and stops on that value. Pressing **<RESET>** sets the clock to 0.00.

During the operations described above, if the display is already counting and a **START** input is triggered, the display will show the elapsed time for 10 seconds and then go back to displaying the running time. If the display is stopped and **<START>** is pressed, the display will continue counting from the stopped time. If the **STOP** input is received fewer than 10 seconds before the **START**, the timer will display the negative value (-9.99) for 10 seconds, and then go to the current running time. The **<HORN>** input manually sounds the horn.

- **START** input will look for a normally closed closure.
- **STOP** input will look for a normally closed closure.
- **HORN** input will look for a normally closed closure.
- **RESET** input will look for a normally closed closure.

5. Game Clock

In this mode, the clock is set in MN:SC.TH format. The display counts down from 59:59.99 to zero, rolls over to 59:59, and continues counting. Or, if a time is programmed, the clock counts down to the programmed time, stops at zero, and sounds the horn.

A setting of 0 tells the display to count down from 59:59.99 to 0, roll over to 59:59 and continue counting. If another value is set, from 00:00 to 99:59, the set value is the number that the timer will go to when **<RESET>** is pressed. When **<START>** is pressed, the timer counts down, stops at zero, and sounds the horn. If a **STOP** input is received during a countdown, the display stops on that time. Next, either press **<START>** to continue counting, or press **<RESET>** to go back to the preset time.

- **START** input will look for a normally open closure.
- **STOP** input will look for a normally open closure.
- **HORN** input will look for a normally open closure.
- **RESET** input will look for a normally open closure.

6. 12-Hour Time of Day

This mode programs the time of day using a 12-hour clock. In this mode, the display shows time in HR:MN:SC format.

The display will keep time in 12-hour format, starting from the preset value. The switch inputs are used only to set the time and mode of operation.

7. 24-Hour Time of Day

This mode displays time of day using a standard, 24-hour military clock. In this mode, the display shows time in HR:MN:SC format.

The display will keep time in 24-hour format starting from the preset value. The switch inputs are only used to set the time and mode of operation.

8. Agility Timer (with normally open Start and Stop)

Time will display as MN:SC.TH.

With the display reset to 0.00, a **START** input will start the display counting. The **STOP** input will be disabled for the first five seconds. Additional **START** inputs will be ignored until the clock is **RESET** to 0.0. Pressing **<STOP>** freezes the running time on the display to a hundredth (0.01) of a second. Pressing **<RESET>** sets the clock to 0.00. Pressing **<RESET>** again returns the clock to the previous time. The **<HORN>** input manually sounds the horn.

- **START** input will look for a normally open closure.
- **STOP** input will look for a normally open closure.
- **HORN** input will look for a normally open closure.
- **RESET** input will look for a normally open closure.

9. Agility Timer (with normally closed Start and Stop)

Time will display as MN:SC.TH.

With the display reset to 0.0, a **START** input will start the display counting. The **STOP** input will be disabled for the first five seconds. Additional **START** inputs will be ignored until the clock is **RESET** to 0.0. Pressing **<STOP>** freezes the running time on the display to a hundredth (0.01) of a second. Pressing **<RESET>** sets the clock to 0.00. Pressing **<RESET>** again returns the clock to the previous time. The **<HORN>** input manually sounds the horn.

- **START** input will look for a normally closed closure.
- **STOP** input will look for a normally closed closure.
- **HORN** input will look for a normally open closure.
- **RESET** input will look for a normally open closure.

10. Self Timer (with special reset/start and normally open stop)

Time will display as MN:SC.TH.

When the **START** input is closed, the display will reset to 0.00. When the **START** input opens, the clock will start counting. Pressing **<STOP>** will freeze the time on the display. Pressing **<RESET>** sets the clock to 0.00. Pressing **<RESET>** again returns the clock to the previous time. The **<HORN>** input manually sounds the horn.

This mode also has the ability to program a countdown to start. Press **<RESET>** once to reset the display to 0.00. Press and hold **<RESET>**. After two seconds the PR:(current program #) will display for one second, then the countdown time will display.

If 0 is showing, the display will start counting up from 0. If, for example, the number 10 is showing, the display will start counting down. While still holding **<RESET>**, toggle **<START>** to set the minutes, and toggle **<STOP>** to set the seconds.

Note: An All Sport control console or an OmniSport timing console can be connected to the TI-2020 or TI-2021 to control it, but the display is then limited to being an output device rather than the self-contained timing system for which it was designed. Also, the seven-digit TI-2021 may be used for field events. In those modes, the display must be connected to an All Sport 1610 console. Refer to the manuals listed in **Display Controllers (p.2)** for control console operation.

5 Display Maintenance

Disconnect power before doing any repair or maintenance work on the display.
Permit only qualified service personnel to access internal display electronics.
Disconnect power when not using the display.

Component Location & Access

Reference Drawings:

Electrical Spec- TI-2020	DWG-178820
Electrical Spec- TI-2021	DWG-305729

The TI-2020 and TI-2021 are front-access displays. All internal electronic components and digits can be reached by opening a digit panel on the front of the display.

With these portable timing displays, the LED driver and key electronic components are located in an enclosure immediately behind the center set of digits. **DWG-178820** and **DWG-305729** in **Appendix A** show component locations for the TI-2020 and TI-2021, respectively.

Digit panels on the displays are held in place by machine screws across the top and bottom of each panel, as shown in **Figure 8**. Open the display with care. Hold the digit panel in place by putting hand pressure on it while removing the screws, and carefully lift it from the cabinet, sliding it outward and down. If the panel is not held in place, it could drop when the screws are removed, possibly damaging LEDs or the digit wiring.

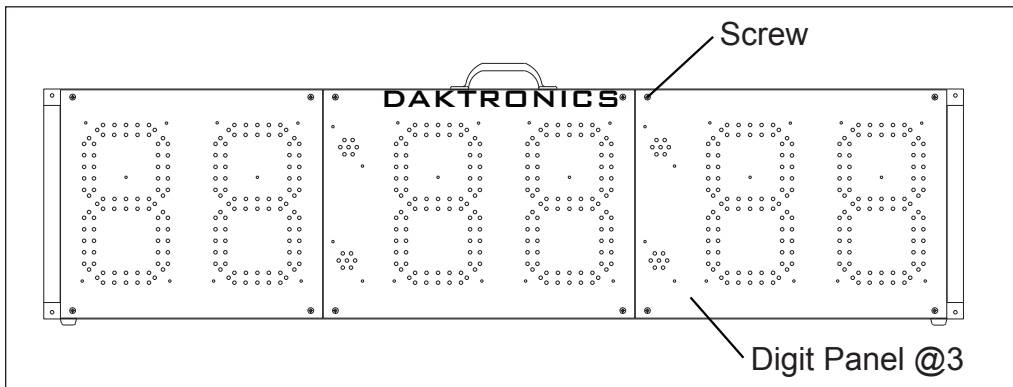

Figure 8: Front View w/ All Digit Panels (TI-2020)

Replacing Digits

LEDs are embedded in a printed circuit board (PCB) that is mounted to the back of the timer's face panel, as shown in **Figure 9**. Newer weather-sealed digits consist of a digit circuit board mounted to a black polycarbonate tray and encased in protective gel, as shown in **Figure 10**. Do not attempt to remove individual LEDs. In the case of a malfunctioning LED or digit segment, replace the entire digit circuit board.

To replace a digit:

1. Open the digit panel as described in **Component Location & Access (p.14)**.
2. Disconnect the plug from the back of the digit by squeezing together the locking tabs and pulling the connector free.
3. Remove the nuts securing the digit to the inside of the panel, and then lift the digit off the studs.

4. Position a new digit over the studs. Make sure the rubber side of the rubber-backed spacers are facing the digit circuit board before tightening the nuts. *Weather-sealed digits do not require these spacers.*
5. Reconnect the plug to the back of the digit. This is a keyed connector and will attach in one way only. Do not force the connection.
6. Close and secure the digit panel, then power up and test the display to verify the issue has been resolved.

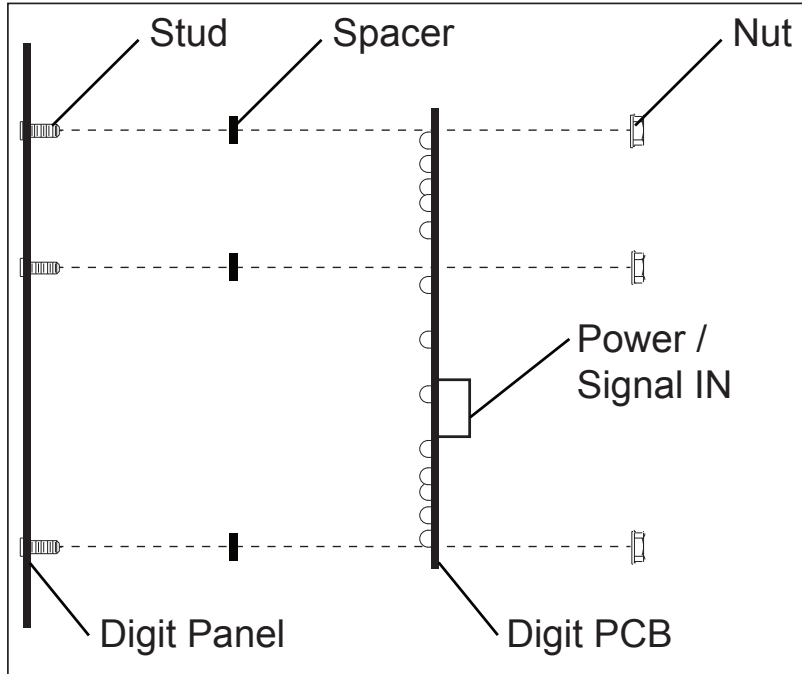

Figure 9: Digit Panel Assembly

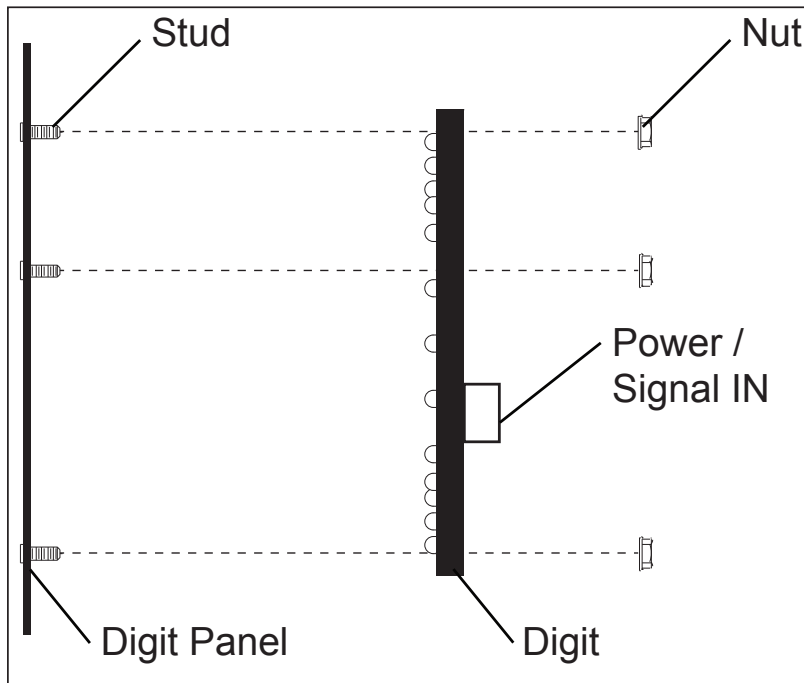

Figure 10: Weather-Sealed Digit Panel Assembly

Replacing Colons & Breakout Board

Like digits, the colon segment circuit boards are mounted to the back of the digit panel. Unlike digits, which connect directly to the driver, the smaller colon segments are connected to a breakout board, which, in turn, connects to the driver. The breakout board is located immediately to the left of the driver and is accessible through the far-left digit panel on the front of the display (**Figure 11**).

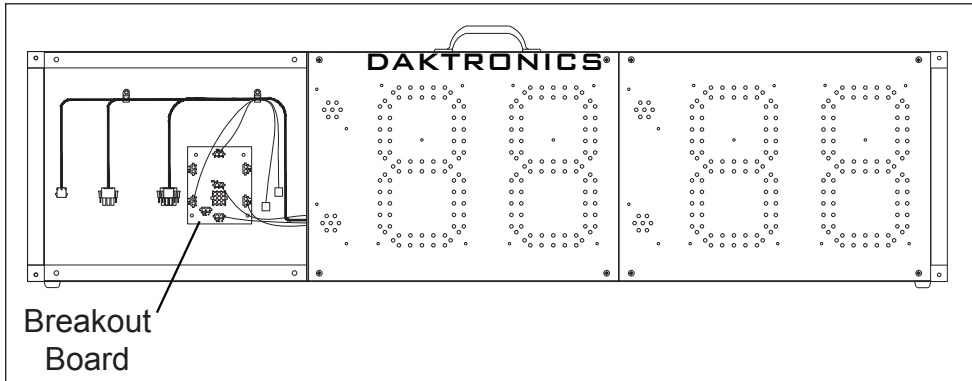

Figure 11: Breakout Board Location (Left Panel Removed)

To replace a colon segment:

1. Open the digit panel as described in **Component Location & Access (p.14)**.
2. Disconnect the 2-pin plug from the back of the colon segment by squeezing together the locking tabs and pulling the connector free.
3. Remove the nuts securing the colon segment to the inside of the panel, and then lift it off the studs.
4. Position a new colon segment over the studs. Make sure the rubber side of the rubber-backed spacers are facing the circuit board before tightening the nuts. *Weather-sealed colon segments do not require these spacers.*
5. Reconnect the plug to the back of the colon segment. This is a keyed connector and will attach in one way only. Do not force the connection.
6. Close and secure the digit panel, then power up and test the display to verify the issue has been resolved.

If all the colon segments are not working, it may be possible to replace just the breakout board instead of every segment. To replace the breakout board:

1. Open the far-left digit panel as described in **Component Location & Access (p.14)**.
2. Disconnect all plugs from the breakout board by squeezing together the locking tabs and pulling the connectors free. It may be helpful to label the cables or take a picture to know which cable goes to which connector when attaching the new breakout board.
3. Remove the nuts securing the breakout board to the inside of the display, and then lift it off the studs.
4. Position a new breakout board over the studs and tighten the nuts.
5. Reconnect all plugs to the breakout board. These are keyed connectors and will attach in one way only. Do not force the connections.
6. Close and secure the digit panel, then power up and test the display to verify the issue has been resolved.

LED Drivers

Reference Drawings:

8 Column MASC LED Driver Specifications **DWG-167237**

The LED driver performs the task of switching digits on and off within the display. The LED driver is located inside a driver enclosure. Refer to **Figure 12** to view the location and components of a driver enclosure for the TI-2020 (the TI-2021 layout is similar). For detailed descriptions and pin-outs of the driver jacks, refer to **DWG-167237** in **Appendix A**.

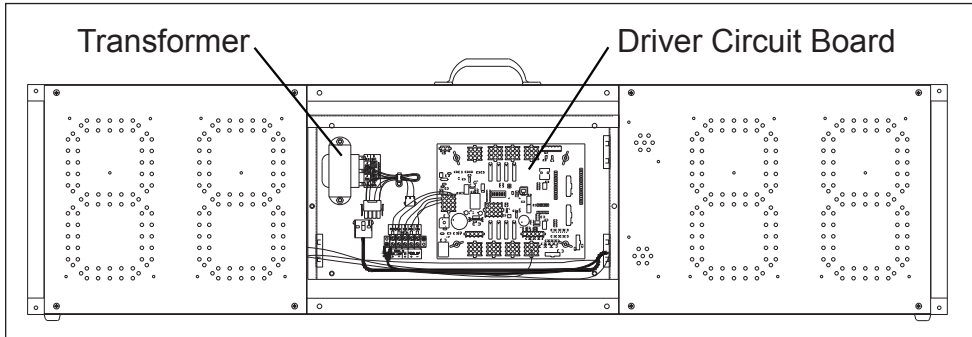

Figure 12: Driver Location & Components (Center Panel & Enclosure Cover Removed)

Replacing a Driver

Figure 13 shows the components of a driver enclosure. Follow the steps below to replace a failed driver.

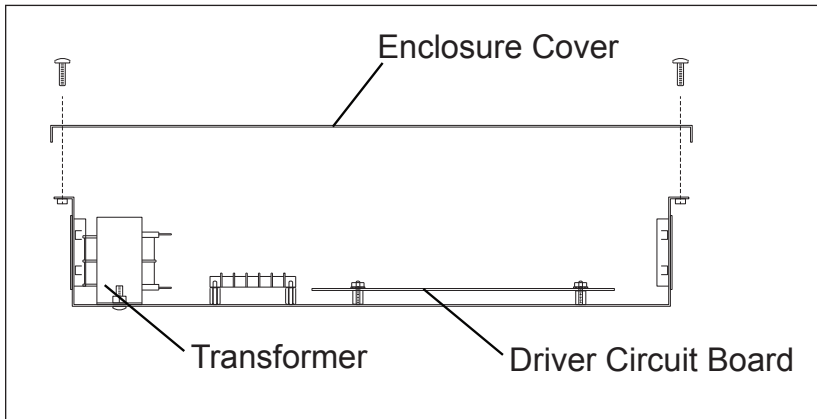

Figure 13: Driver Enclosure Assembly (Bottom View)

1. Open the center digit panel as described in **Component Location & Access (p.14)**.

Note: Older display models may require removal of all three front panels to access the driver.

2. Remove the screws to take off driver enclosure cover.
3. Disconnect all plugs from the driver by squeezing together the locking tabs and pulling the connectors free. It may be helpful to label the cables or take a picture to know which cable goes to which connector when attaching the new driver.
4. Remove the nuts securing the driver to the inside of the enclosure.
5. Carefully lift the driver from the display and place it on a clean, flat surface.
6. Position a new driver over the studs and tighten the nuts.

7. Reconnect all plugs to their mating jacks on the driver. These are keyed connectors and will attach in one way only. Do not force the connections.
8. Ensure the new driver is set to the correct address. This will be the same address of the old driver being replaced. Refer to **Setting the Driver Address (p.18)**.
9. Close and secure the driver enclosure and digit panel, then power up and test the display to verify the issue has been resolved.

Setting the Driver Address

Since the same LED drivers can be used for many display models, each driver must be set to receive the correct signal input, or address, for the model being used.

TI-2020 and TI-2021 both use **Address 22**. This address is set with jumper wires in a 12-pin plug which mates with jack **J19** on the driver (**Figure 14**). It may be possible to reuse the same address plug from the driver that was replaced. If not, order a fully-loaded address plug (Daktronics part # 0A-1150-0064) and set it to **Address 22** by cutting the following pins: 2 (brown), 6 (tan), 9 (blue), 11 (violet), and 12 (black).

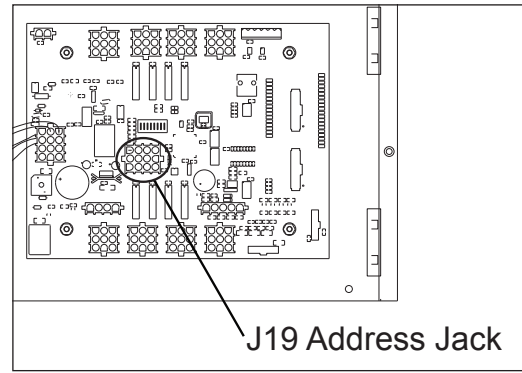

Figure 14: J19 Address Jack

The address on newer displays may instead be set via an 8-position DIP switch located just above the **J19** address jack. Using a pen or small pointed object, set the driver to **Address 22** by setting the following switches to OFF: 1, 4, 6, 7, 8.

Segmentation & Digit Designation

Reference Drawings:

Segmentation, 7 Segment Bar Digit **DWG-38532**

In each digit, certain LEDs always go on and off together. These groupings of LEDs are referred to as segments. **DWG-38532** in **Appendix A** details which connector pin is wired to each digit segment and the wiring color code used throughout the display.

The electrical specifications drawings in **Appendix A** specify the driver connectors controlling the digits. Numbers shown in hexagons in the upper half of each digit indicate which connector is wired to that digit.

Schematics

Reference Drawings:

Schematic: TI-2021 120 or 240VAC **DWG-304812**

Schematic and Harness: TI-2020 **DWG-314313**

For advanced display troubleshooting and repair, it may be necessary to consult the schematic drawings. **DWG-304812** and **DWG-314313** in **Appendix A** show detailed power and signal wiring diagrams of internal display components for the TI-2021 and TI-2020, respectively.

Replacement Parts

The following table contains display components that may require replacement. Many of the other display components will have attached part number labels.

Description	Part Number
Horn, 120V with 2-pin plug	0A-1152-0332
Wall Mounting Kit	0A-1153-0363
10" LED digit, Red	0A-1192-6121
10" LED digit, Amber	0A-1192-5221
Colon, Red (hexagon-shaped)	0A-1611-6133
Colon, Amber (hexagon-shaped)	0A-1611-5233
Segment Breakout Board	0P-1192-0019
8 Column LED Driver, S.A.T.	0P-1192-0093
Colon, Red (square-shaped)	0P-1192-0272
Colon, Amber (square-shaped)	0P-1192-0273
Tripod, Speaker Stand Type	A-1580
Tripod Adapter	HS-1306
Transformer; 115/230V, 6.35A	T-1066
Power Cord, 360° Rotating, 8'	W-1181

Refer to **Section 6: Daktronics Exchange and Repair & Return Programs (p.20)** for information on exchanging or returning parts.

6 Daktronics Exchange and Repair & Return Programs

Exchange Program

The Daktronics Exchange Program is a service for quickly replacing key components in need of repair. If a component fails, Daktronics sends a replacement part to the customer who, in turn, returns the failed component to Daktronics. This decreases equipment downtime. Customers who follow the program guidelines explained below will receive this service.

Before contacting Daktronics, identify these important numbers:

Display Serial Number: _____

Display Model Number: _____

Job/Contract Number: _____

Date Manufactured/Installed: _____

Daktronics Customer ID Number: _____

To participate in the Exchange Program, follow these steps:

1. Call Daktronics Customer Service.

United States & Canada: 1-800-DAK-TRON (325-8766)

Outside the U.S. & Canada: +1-605-275-1040

2. When the new exchange part is received, mail the old part to Daktronics.

If the replacement part fixes the problem, send in the problem part being replaced.

- a. Package the old part in the same shipping materials in which the replacement part arrived.
- b. Fill out and attach the enclosed UPS shipping document.
- c. Ship the part to Daktronics.

3. The defective or unused parts must be returned to Daktronics within 5 weeks of initial order shipment.

If any part is not returned within five (5) weeks, a non-refundable invoice will be presented to the customer for the costs of replenishing the exchange parts inventory with a new part. Daktronics reserves the right to refuse parts that have been damaged due to acts of nature or causes other than normal wear and tear.

Repair & Return Program

For items not subject to exchange, Daktronics offers a Repair & Return Program. To send a part for repair, follow these steps:

1. Call Daktronics Customer Service.

United States & Canada: 1-800-DAK-TRON (325-8766)

Outside the U.S. & Canada: +1-605-275-1040

2. Receive a case number before shipping.

This expedites repair of the part.

3. Package and pad the item carefully to prevent damage during shipment.

Electronic components, such as printed circuit boards, should be placed in an antistatic bag before boxing. Daktronics does not recommend using packing peanuts when shipping.

4. Enclose:

- name
- address
- phone number
- the case number
- a clear description of symptoms

5. Ship to:

Daktronics Customer Service

[Case #]

201 Daktronics Drive, Dock E

Brookings, SD 57006

Daktronics Warranty & Limitation of Liability

The Daktronics Warranty & Limitation of Liability is located at the end of this manual. The Warranty is independent of Extended Service agreements and is the authority in matters of service, repair, and display operation.

This page intentionally left blank.

A Reference Drawings

Refer to **Resources (p.2)** for information regarding how to read the drawing number. Any contract-specific drawings take precedence over the general drawings.

Reference Drawings:

Segmentation, 7 Segment Bar Digit	DWG-38532
8 Column MASC LED Driver Specifications	DWG-167237
Electrical Spec- TI-2020	DWG-178820
Mechanical Spec- TI-2020 and TI-2021	DWG-178822
Schematic: TI-2021 120 or 240VAC	DWG-304812
Electrical Spec- TI-2021	DWG-305729
Schematic and Harness: TI-2020	DWG-314313
Assy Drawing - Radio Placement On TI-2020.....	DWG-409066
Installation, Portable Powered Scoreboards.....	DWG-1039104

This page intentionally left blank.

7 SEGMENT BAR DIGIT

FRONT VIEW

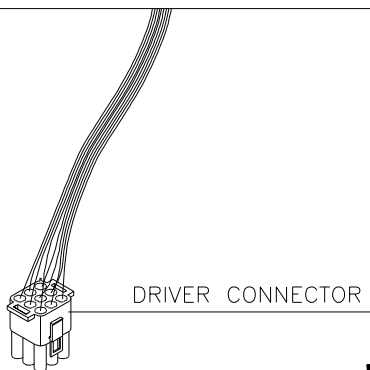
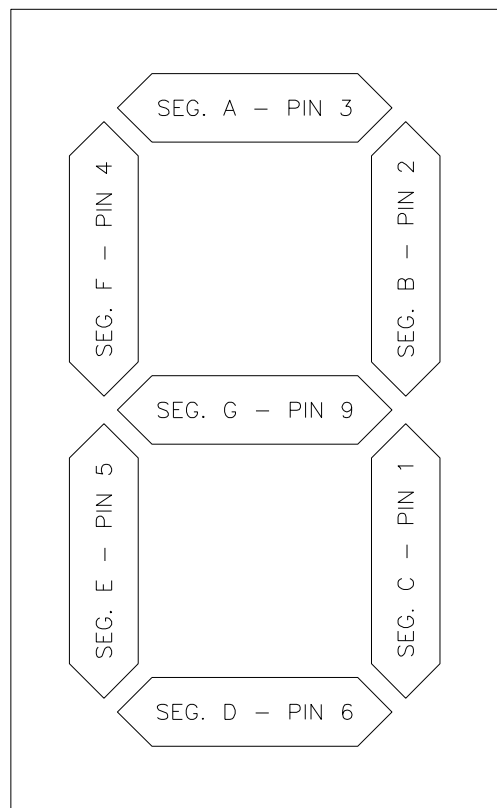

DRIVER CONNECTOR

EFFECTIVE APRIL 2021
ALL WIRE COLORS CHANGED
TO BLACK

COLOR CODE		
PIN NO.	WIRE COLOR	DRIVER SEGMENT
1	ORN	C
2	RED	B
3	BRN	A
4	BLU	F
5	PNK	E
6	TAN	D
7	BLK	COM.
8	GRY	H
9	VIO	G

NOTE: "H" SEGMENT, GRAY WIRE IS NOT USED ON 7 SEGMENT BAR DIGIT.

CONNECTOR PIN NUMBERING

NOTE SPLINE NEAR NO. 1

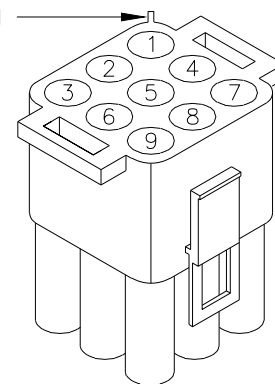

REV 03	DATE: 20 APR 21	CN118578 ADDED NOTE TO CALL OUT CHANGE OF WIRE COLOR TO BLACK EFFECTIVE APRIL 2021.	BY: JSF
		THE CONCEPTS EXPRESSED AND DETAILS SHOWN ON THIS DRAWING ARE CONFIDENTIAL AND PROPRIETARY. DO NOT REPRODUCE BY ANY MEANS WITHOUT THE EXPRESS WRITTEN CONSENT OF DAKTRONICS, INC. OR ITS WHOLLY OWNED SUBSIDIARIES. COPYRIGHT 2021 DAKTRONICS, INC. (USA)	
PROJECT: BASKETBALL			
TITLE: SEGMENTATION- 7 SEGMENT BAR DIGIT			
DATE: 05 JUN 89	DIM UNITS: INCHES [MILLIMETERS]		SHEET
SCALE: 1=4	DO NOT SCALE DRAWING		REV
DESIGN: AVB	JOB NO.	FUNC - TYPE - SIZE	38532
DRAWN: HEIDERSCHIEDT P1192	-	- A	

2	30 APR 97	ADDED SEGMENT DESIGNATIONS TO DIGIT FIGURE.	AVB	AVB
1	2 JAN 92	CHANGED FROM B-SIZE TO A-SIZE DWG.	C FICK	

J23 +12VDC	
PIN	FUNCTION
1	+12VDC-P
2	GND-N

OP-1192-0081 UNCOATED
OR OP-1192-0082 COATED
8 COLUMN MASC LED DRIVER

TB1 - CAN	
PIN	FUNCTION
1	N/C
2	+5V-P
3	CANH-P
4	CANL-P
5	GND-N
6	GND-N

J24	
PIN	FUNCTION
1	MODEM_RTS-P
2	MODEM_RESET-P
3	MODEM_TX-P
4	GND-N
5	MODEM_RX-P
6	MODEM_DCD-P

J25			
FUNCTION	PIN	PIN	FUNCTION
ID3-P	21	20	GND-N
FREE0-P	22	19	GND-N
ID2-P	23	18	GND-N
ROWSEL2-P	24	17	GND-N
GRN.DIM-P	25	16	GND-N
CLK-P	26	15	GND-N
GRN4-P	27	14	GND-N
RED4-P	28	13	GND-N
GRN3-P	29	12	GND-N
RED3-P	30	11	GND-N
GRN2-P	31	10	GND-N
RED2-P	32	9	GND-N
GRN1-P	33	8	GND-N
RED1-P	34	7	GND-N
RED.DIM-P	35	6	GND-N
LAT-P	36	5	GND-N
ROWSEL1-P	37	4	GND-N
ROWSEL0-P	38	3	GND-N
ID1-P	39	2	GND-N
ID0-P	40	1	GND-N

J19 - ADDRESS	
PIN	FUNCTION
1	GND-N
2	ADD0-N
3	ADD1-N
4	GND-N
5	ADD2-N
6	ADD3-N
7	GND-N
8	ADD4-N
9	ADD5-N
10	GND-N
11	ADD6-N
12	ADD7-N

J17 - MAIN	
PIN	FUNCTION
1	CLIN-P
2	CLIN-N
3	232IN-P
4	CLOUT-P
5	CLOUT-N
6	16VAC-P
7	GND-N
8	N/C
9	16VAC-N
10	GND-N
11	N/C
12	+VBB-P

J18 - RELAY	
PIN	FUNCTION
1	HORNOUT-N
2	AUXOUT-N
3	120SW1-N
4	120SW1-P

J1-8 DIGITS	
PIN	FUNCTION
1	SEGC-N
2	SEGB-N
3	SEGA-N
4	SEGF-N
5	SEGE-N
6	SEGD-N
7	+VBB-P
8	SEGH-N
9	SEGG-N

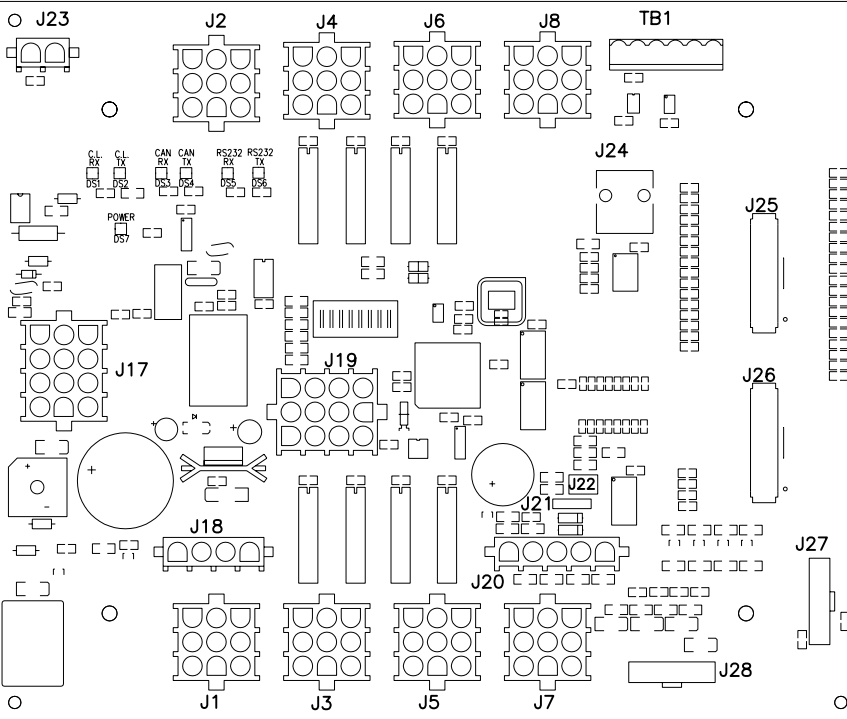

J20 - PROTOCOL	
PIN	FUNCTION
1	GND
2	PRO-N
3	PR1-N
4	PR2-N
5	PR3-N

J21 - ISP	
PIN	FUNCTION
1	VFP-P
2	BKD-P
3	GND-N
4	RESET-P

J22 - ISP	
PIN	FUNCTION
1	BKD-P
2	GND-N
3	N/C
4	RESET-P
5	VFP-P
6	+5V-P

J28 - SWITCH	
PIN	FUNCTION
1	SWITCH1-P
2	SWITCH1-N
3	SWITCH2-P
4	SWITCH2-N
5	SWITCH3-P
6	SWITCH3-N
7	SWITCH4-P
8	SWITCH4-N

J27 - TPIC	
PIN	FUNCTION
8	GND-N
7	GND-N
6	DIG.DATA-P
5	DIG.STROBE-P
4	DIG.CLK-P
3	DIG.OE-N
2	+VBB-P
1	+5V-P

J26			
FUNCTION	PIN	PIN	FUNCTION
N/C	21	20	GND-N
FREE0-P	22	19	GND-N
N/C	23	18	GND-N
ROWSEL2-P	24	17	GND-N
GRN.DIM-P	25	16	GND-N
CLK-P	26	15	GND-N
N/C	27	14	GND-N
N/C	28	13	GND-N
N/C	29	12	GND-N
N/C	30	11	GND-N
GRN2-P	31	10	GND-N
RED2-P	32	9	GND-N
GRN1-P	33	8	GND-N
RED1-P	34	7	GND-N
RED.DIM-P	35	6	GND-N
LAT-P	36	5	GND-N
ROWSEL1-P	37	4	GND-N
ROWSEL0-P	38	3	GND-N
N/C	39	2	GND-N
N/C	40	1	GND-N

NOTES:

- WITH NO ADDRESS PINS SELECTED THE DRIVER WILL DEFAULT TO STANDARD PROTOCOL.
- RED LED DS1 WILL BE ON WHEN THE DRIVER IS RECEIVING CURRENT LOOP SIGNAL AND OFF WHEN THERE IS NO SIGNAL.
- GREEN LED DS2 WILL BE ON WHEN THE DRIVER TRANSMITS CURRENT LOOP SIGNAL.
- RED LED DS3 WILL BLINK WHEN THE DRIVER RECEIVES CAN SIGNAL.
- GREEN LED DS4 WILL BLINK WHEN THE DRIVER TRANSMITS CAN SIGNAL.
- IF BOTH DS3 AND DS4 ARE ON CONTINUOUSLY, THE CAN BUS IS IN AN ERROR STATE (NO CONNECTION TO CAN NETWORK).
- RED LED DS5 WILL BE ON WHEN THE DRIVER RECEIVES RS-232 SIGNAL.
- GREEN LED DS6 WILL BE ON WHEN THE DRIVER TRANSMITS RS-232 SIGNAL.
- GREEN LED DS7 INDICATES THAT THE DRIVER HAS POWER.

THE CONCEPTS EXPRESSED AND DETAILS SHOWN ON THIS DRAWING ARE CONFIDENTIAL AND PROPRIETARY. DO NOT REPRODUCE BY ANY MEANS, INCLUDING ELECTRONICALLY WITHOUT THE EXPRESSED WRITTEN CONSENT OF DAKTRONICS, INC. COPYRIGHT 2004 DAKTRONICS, INC.			
DAKTRONICS, INC. BROOKINGS, SD 57006			
PROJ:			
TITLE: 8 COLUMN MASC LED DRIVER SPECIFICATIONS			
DES. BY:		DRAWN BY: JSPAHR	
		DATE: 16 MAY 02	
REVISION	APPR. BY:	1192-R07A-167237	
02	SCALE: 1=2		

REV.	DATE	DESCRIPTION	BY	APPR.
02	22 NOV 04	CHANGED NOTES RELATING TO LED FUNCTIONS.	AVB	
01	06 JUN 02	ADDED NEW NOTES ADDED LABELS TO LEDS	JJS	

TI-2020

DIGIT, SIGNAL AND POWER SPECIFICATIONS:

NOTES

1. USE MINIMUM OF 22AWG, SHIELDED, TWO CONDUCTOR CABLE FOR SIGNAL TERMINATION.
2. THE NUMBER LISTED IN EACH DIGIT INDICATES THE DRIVER CONNECTOR WIRED TO THAT DIGIT.
3. DO NOT WORK ON ENERGIZED DISPLAY UNLESS YOU ARE A CERTIFIED ELECTRICIAN OR DIRECTED BY DAKTRONICS.
4. REQUIRES A 120V AC, 15 AMP CIRCUIT.
5. MAXIMUM POWER CONSUMPTION IS APPROXIMATELY 100 WATTS.

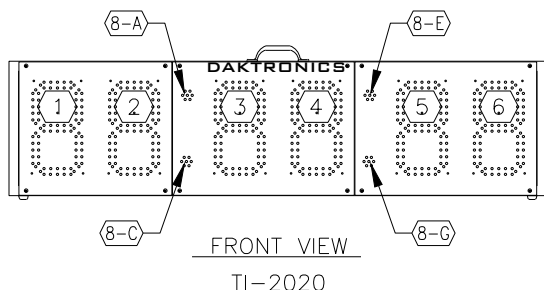

ADDRESS INFORMATION	
DRIVER:	A1
ADDRESS:	22

COMPONENT LOCATIONS:

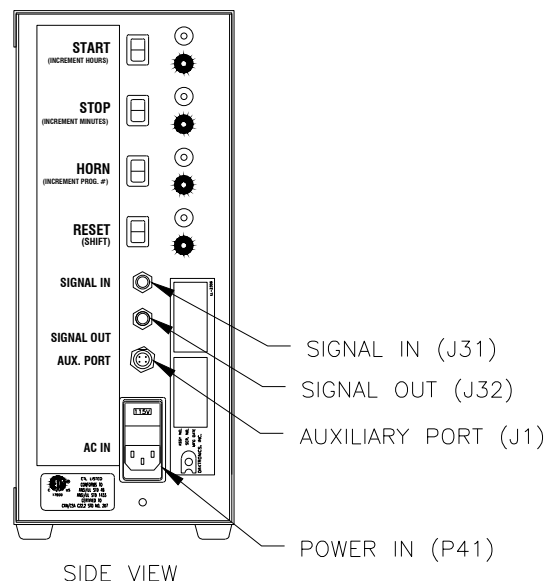
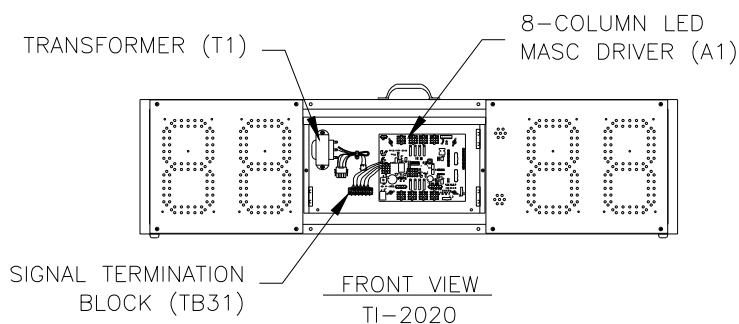

REV	DATE:	DESCRIPTION	BY:
04	19 JUN 14	UPDATED COLON LED LAYOUT	KDD
03	30 APR 09	UPDATED SIDE VIEW DRAWING TO INCLUDE FUSE HOLDER	MRH
02	18 MAY 07	REMOVED ALL TI-2021 REFERENCES MOVED TO DWG-305729	KZB
01	07 JAN 03	CHANGED TO 8-COLUMN DRIVER AND SMALLER DRIVER ENCLOSURE.	AVB

 DAKTRONICS, INC. BROOKINGS, SD 57006	THE CONCEPTS EXPRESSED AND DETAILS SHOWN ON THIS DRAWING ARE CONFIDENTIAL AND PROPRIETARY. DO NOT REPRODUCE BY ANY MEANS WITHOUT THE EXPRESS WRITTEN CONSENT OF DAKTRONICS, INC. COPYRIGHT 2014 DAKTRONICS, INC.		
	DO NOT SCALE DRAWING		
PROJ.: LED AQUATICS SCOREBOARD			
TITLE: ELECTRICAL SPEC- TI-2020			
DESIGN: AVANBEMMEL		DRAWN: JJSYRSTAD	
SCALE: 1=20		DATE: 20 NOV 02	
SHEET	REV	JOB NO:	FUNC -TYPE-SIZE
	04	P1153	E - 10 - A
			178820

TI-2020 & TI-2021

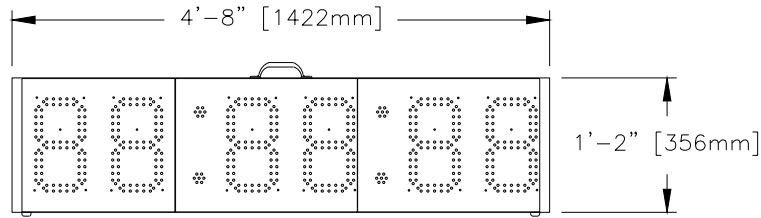

FRONT VIEW
TI-2020

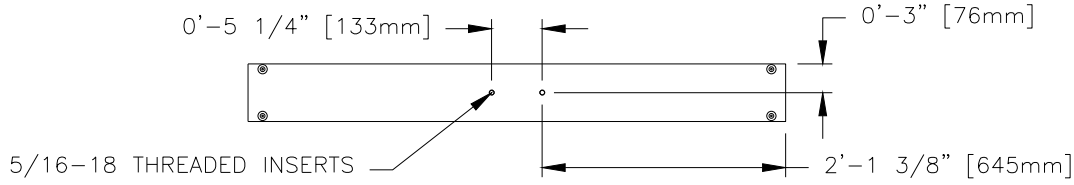

BOTTOM VIEW
TI-2020

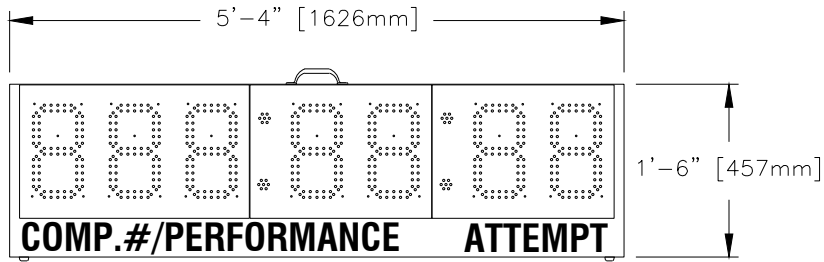

FRONT VIEW
TI-2021

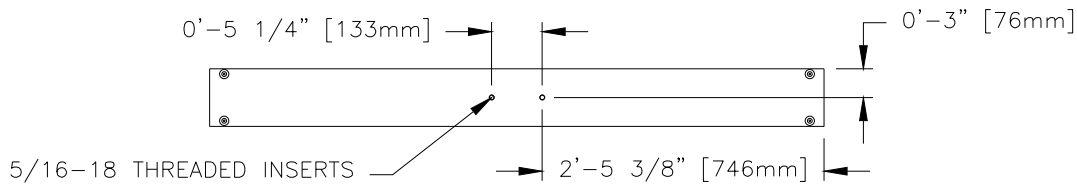

BOTTOM VIEW
TI-2021

	WEIGHTS	
DISPLAY	SHIPPING WEIGHT	DISPLAY WEIGHT
TI-2020	65 LBS (30 KG)	50 LBS (23 KG)
TI-2021	75 LBS (34 KG)	60 LBS (27 KG)

DAKTRONICS, INC. BROOKINGS, SD 57006 DO NOT SCALE DRAWING	THE CONCEPTS EXPRESSED AND DETAILS SHOWN ON THIS DRAWING ARE CONFIDENTIAL AND PROPRIETARY. DO NOT REPRODUCE BY ANY MEANS WITHOUT THE EXPRESS WRITTEN CONSENT OF DAKTRONICS, INC. COPYRIGHT 2014 DAKTRONICS, INC.				
	PROJ: LED AQUATICS SCOREBOARD TITLE: MECHANICAL SPEC- TI-2020 AND TI-2021 DESIGN: AVANBEMMEL DRAWN: JJSYRSTAD DATE: 20 NOV 02 SCALE: 1=20				
REV 01 DATE: 19 JUN 14 UPDATED COLON LED LAYOUT BY: KDD	SHEET	REV 01	JOB NO: P1153	FUNC-TYPE-SIZE E-10-A	178822

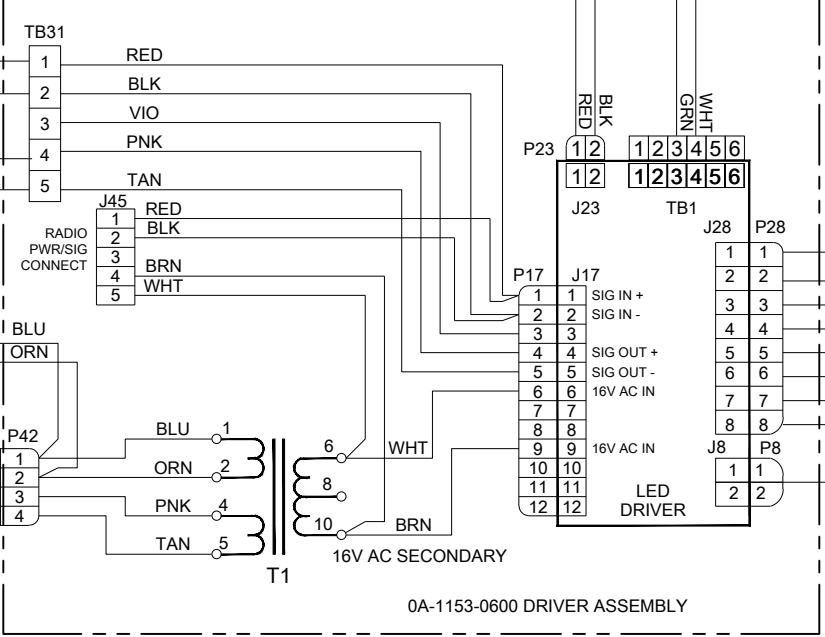
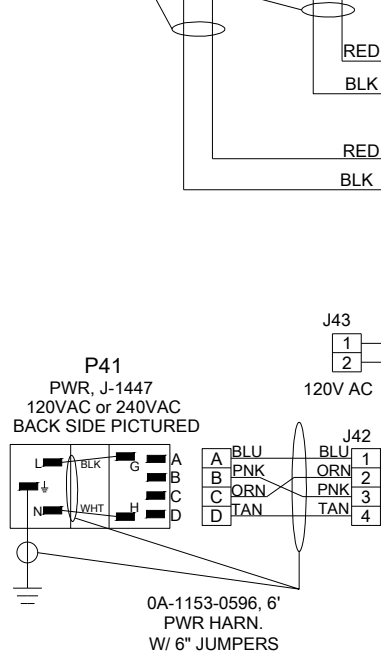
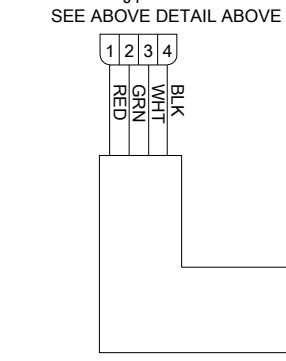
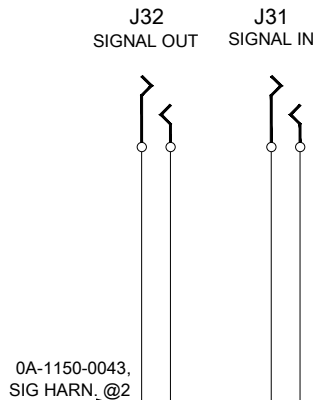
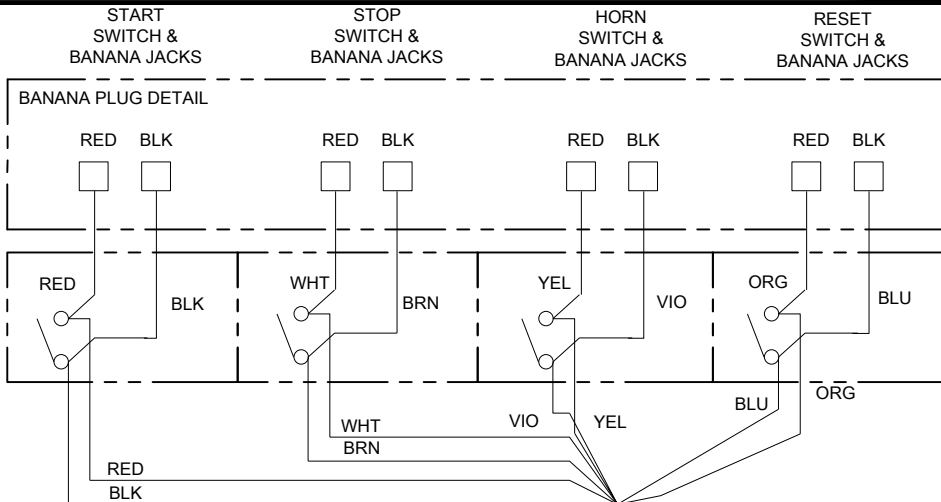
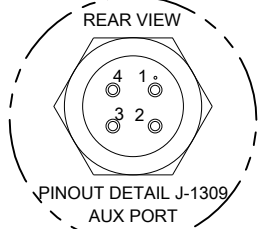

0A-1153-0358, SW & DATA TERM. HARNESS

0P-1192-0019 A1-10 BREAKOUT BOARD

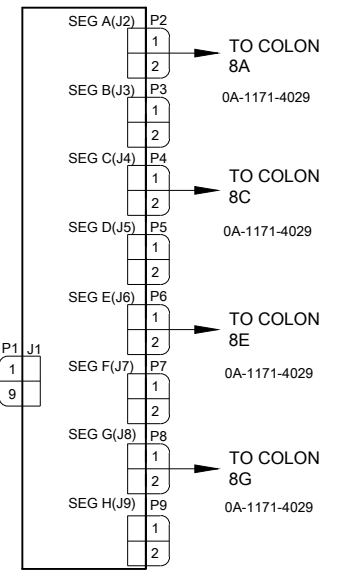

DAKTRONICS THE CONCEPTS EXPRESSED AND DETAILS SHOWN ON THIS DRAWING ARE CONFIDENTIAL AND PROPRIETARY. DO NOT REPRODUCE BY ANY MEANS WITHOUT THE EXPRESS WRITTEN CONSENT OF DAKTRONICS, INC. OR ITS WHOLLY OWNED SUBSIDIARIES. COPYRIGHT 2024 DAKTRONICS, INC. (USA)

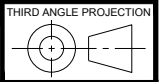

REV 04	DATE: 03 APR 09	CHANGED 0A-1230-0075/76 TO 0A-1171-4029	BY: SJN	REV 07	DATE: 29 JAN 24	PER CN-245164, UPDATED HARNESS VIEW ON T1	BY: MTR
REV 03	DATE: 30 JAN 08	FIX HORN WIRING	BY: KZB	REV 06	DATE: 10 MAR 16	MOVED RED WIRE ON TB31-3 TO TB31-1	BY: MTR
REV 02	DATE: 26 JUL 07	UPDATE WIRE COLORS ON 0A-1153-0596	BY: KZB	REV 05	DATE: 21 JUN 12	CHANGED 0A-1153-0358 TO HAVE JACKETED CABLE PER EC-5976	BY: JML
REV 01	DATE: 17 JUL 07	UPDATED J-1447	BY: AMG				

PROJECT: LED AQUATICS SCOREBOARD			
TITLE: SCHEMATIC: TI-2021 120 OR 240VAC			
DATE: 14 MAY 07	DIM UNITS: INCHES [MILLIMETERS]	SHEET	REV
SCALE: NONE	DO NOT SCALE DRAWING	1 OF 1	07
DESIGN:	JOB NO. P1153	FUNC - TYPE - SIZE R - 03 - A	304812
DRAWN: KBIERBA			

TI-2021

DIGIT, SIGNAL AND POWER SPECIFICATIONS:

NOTES

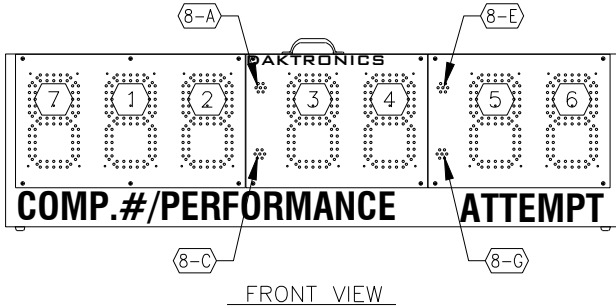

1. USE MINIMUM OF 22AWG, SHIELDED, TWO CONDUCTOR CABLE FOR SIGNAL TERMINATION.
2. THE NUMBER LISTED IN EACH DIGIT INDICATES THE DRIVER CONNECTOR WIRED TO THAT DIGIT.
3. DO NOT WORK ON ENERGIZED DISPLAY UNLESS YOU ARE A CERTIFIED ELECTRICIAN OR DIRECTED BY DAKTRONICS.
4. REQUIRES A 120-240V AC, 15 AMP CIRCUIT.
5. MAXIMUM POWER CONSUMPTION IS APPROXIMATELY 100 WATTS.

ADDRESS INFORMATION	
DRIVER:	A1
ADDRESS:	22

COMPONENT LOCATIONS:

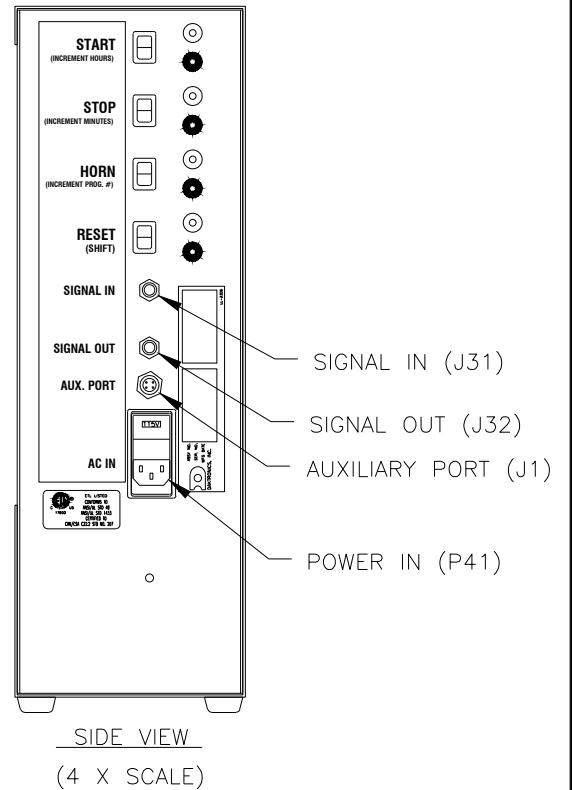
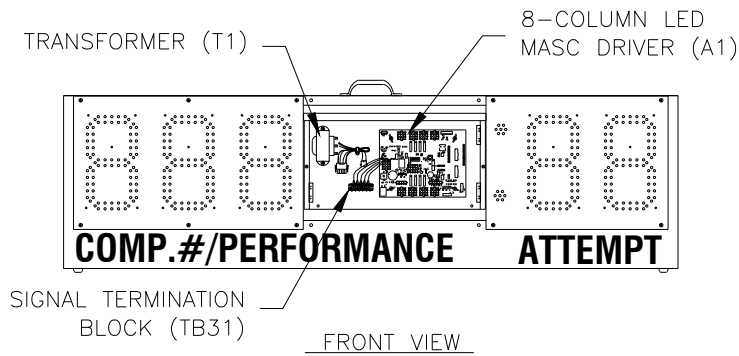

DAKTRONICS, INC. BROOKINGS, SD 57006 DO NOT SCALE DRAWING	THE CONCEPTS EXPRESSED AND DETAILS SHOWN ON THIS DRAWING ARE CONFIDENTIAL AND PROPRIETARY. DO NOT REPRODUCE BY ANY MEANS WITHOUT THE EXPRESSED WRITTEN CONSENT OF DAKTRONICS, INC. COPYRIGHT 2013 DAKTRONICS, INC.	
	PROJ: LED AQUATICS SCOREBOARD TITLE: ELECTRICAL SPEC- TI-2021	
DESIGN:	DRAWN: KBIERBA	DATE: 18 MAY 06
SCALE: 1=20		
SHEET	REV	JOB NO:
	02	P1153
FUNC - TYPE - SIZE		305729
E - 10 - A		

REV 02	DATE: 19 JUN 14	UPDATED COLONS TO NEW LED LAYOUT	BY: KDD
REV 01	DATE: 30 APR 09	ADDED FUSE HOLDER IN P41	BY: MRH

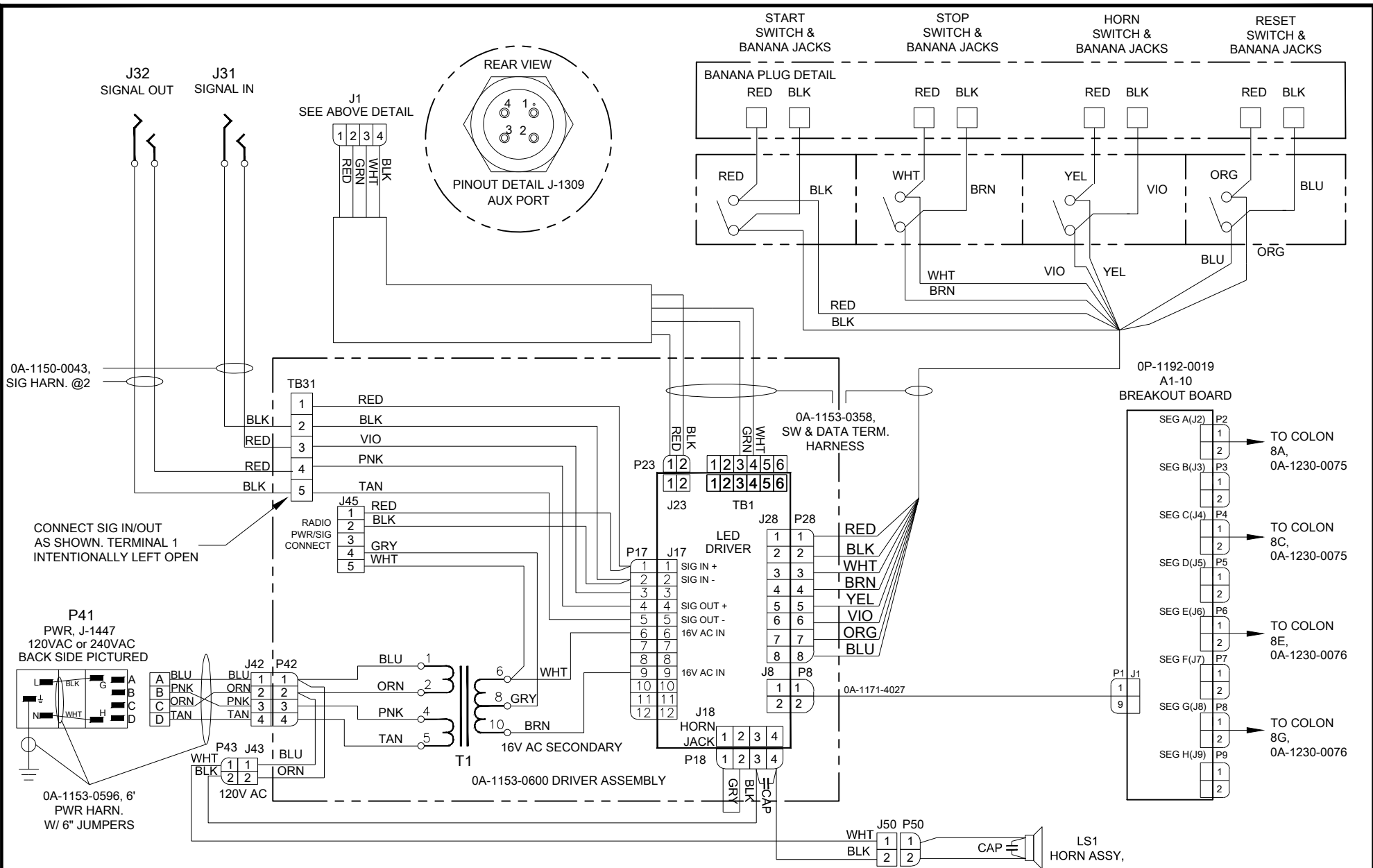

0A-1150-0043,
SIG HARN. @2

CONNECT SIG IN/OUT
AS SHOWN. TERMINAL 1
INTENTIONALLY LEFT OPEN

P41
PWR, J-1447
120VAC or 240VAC
BACK SIDE PICTURED

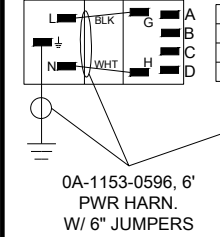

0A-1153-0596, 6'
PWR HARN.
W/ 6" JUMPERS

REV 03	DATE: 29 JAN 24	PER CN-245164, UPDATED HARNESS VIEW ON T1	BY: MTR
REV 02	DATE: 29 APR 14	ADDED HORN CONNECTION DETAIL TO SCHEMATIC	BY: MWM
REV 01	DATE: 21 JUN 12	ADDED JACKET TO 0A-1153-0358 PER EC-5976	BY: JML

		THE CONCEPTS EXPRESSED AND DETAILS SHOWN ON THIS DRAWING ARE CONFIDENTIAL AND PROPRIETARY. DO NOT REPRODUCE BY ANY MEANS WITHOUT THE EXPRESS WRITTEN CONSENT OF DAKTRONICS, INC. OR ITS WHOLLY OWNED SUBSIDIARIES. COPYRIGHT 2024 DAKTRONICS, INC. (USA)		
		PROJECT: LED AQUATICS SCOREBOARD		
TITLE: SCHEMATIC AND HARNESS: TI-2020				
DATE: 27 JUL 07		DIM UNITS: INCHES [MILLIMETERS]		SHEET
SCALE: 1=1		DO NOT SCALE DRAWING		REV 03
DESIGN:	JOB NO. P1153	FUNC - TYPE - SIZE R - 03 - A		
DRAWN: KBIERBA		<div style="float: right; font-size: 24pt; font-weight: bold;">314313</div>		

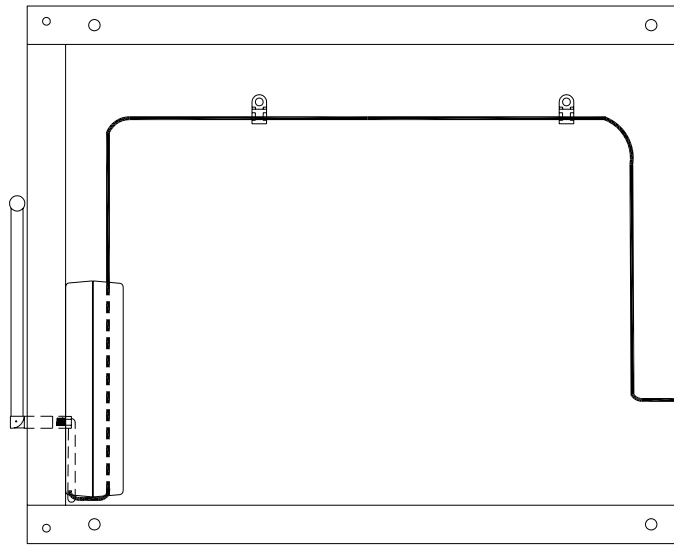

FRONT LEFT VIEW
WITHOUT DIGITS

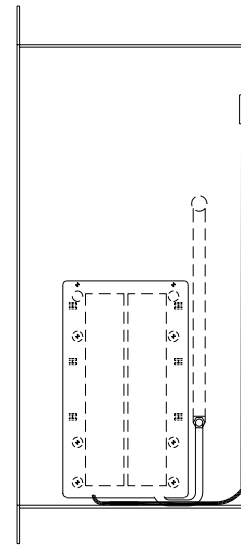

RIGHT SIDE VIEW
FRONT OF RADIO

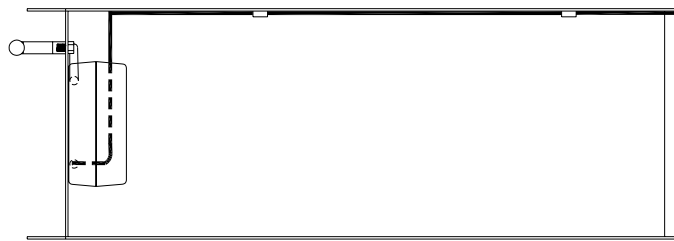

TOP VIEW

- STEP 1
TURN OFF ALL POWER TO SCOREBOARD. MOUNT THE RADIO CENTERED ON THE LEFT INSIDE WALL OF THE SCOREBOARD APPROXIMATELY .25" FROM THE BOTTOM USING 2, 5" PIECES OF VELCRO.
- STEP 2
DRILL A 9/32" HOLE TO THE RIGHT OF THE RADIO APPROXIMATELY 2" FROM THE BOTTOM OF THE RADIO.
- STEP 3
FEED THE ANTENNA CABLE FROM THE RADIO THROUGH THE 9/32" HOLE AND ATTACH IT TO THE LEFT HAND SIDE OF THE SCOREBOARD WITH THE SUPPLIED LOCK WASHER AND NUT.
- STEP 4
ATTACH THE ANTENNA ON THE LEFT HAND OUTSIDE OF THE SCOREBOARD TO THE ANTENNA CABLE THAT HAS BEEN FED THROUGH. BE SURE THE ANTENNA IS POINTING UP.

- STEP 5
LOCATE THE 5 PIN JACK IN THE DRIVER TRAY HARNESS. CHECK TO SEE IF THERE IS A GRAY WIRE PLEASE REFER TO DRAWING A-181729 FOR UPDATE AND INSTRUCTIONS. IF THERE IS A BROWN WIRE IN POSITIONS 3 OF J45 CONTINUE INSTALLATION. PLUG THE 5 PIN MALE PLUG FROM THE RADIO RECEIVER INTO THE MATING 5 PIN JACK (J45) ON THE DRIVER PANEL.
- STEP 6
CLOSE SCOREBOARD POWER/SIGNAL ACCESS DOOR. TURN POWER ON TO SCOREBOARD. THE RADIO RECEIVER IS NOW READY FOR OPERATION.
- STEP 7
TO SET THE CHANNEL REFER TO ED-13831, APPENDIX A, DRAWING A-203542, COLUMN 1, STEPS 1 THROUGH 4

THE CONCEPTS EXPRESSED AND DETAILS SHOWN ON THIS DRAWING ARE CONFIDENTIAL AND PROPRIETARY. DO NOT REPRODUCE BY ANY MEANS, INCLUDING ELECTRONICALLY WITHOUT THE EXPRESSED WRITTEN CONSENT OF DAKTRONICS, INC. COPYRIGHT 2008 DAKTRONICS, INC.			
DAKTRONICS, INC. BROOKINGS, SD 57006			
PROJ: LED AQUATICS SCOREBOARD			
TITLE: ASSY DRAWING - RADIO PLACEMENT ON TI-2020			
DES. BY: BLHOFFMA		DRAWN BY: BLHOFFMA	
		DATE: 12 MAY 08	
REVISION	APPR. BY:	1153-E10A-409066	
00	SCALE: 1 = 5		

REV.	DATE	DESCRIPTION	BY	APPR.

**** NOTE ****

1. ALL ELECTRICAL INSTALLATIONS MUST MEET LOCAL AND NATIONAL ELECTRICAL CODES. INSTALLATION MUST BE PERFORMED BY QUALIFIED PERSONNEL.
2. CUSTOMER SUPPLIED POWER PACK INTENDED FOR TEMPORARY POWER FOR SCOREBOARDS.

REAR VIEW

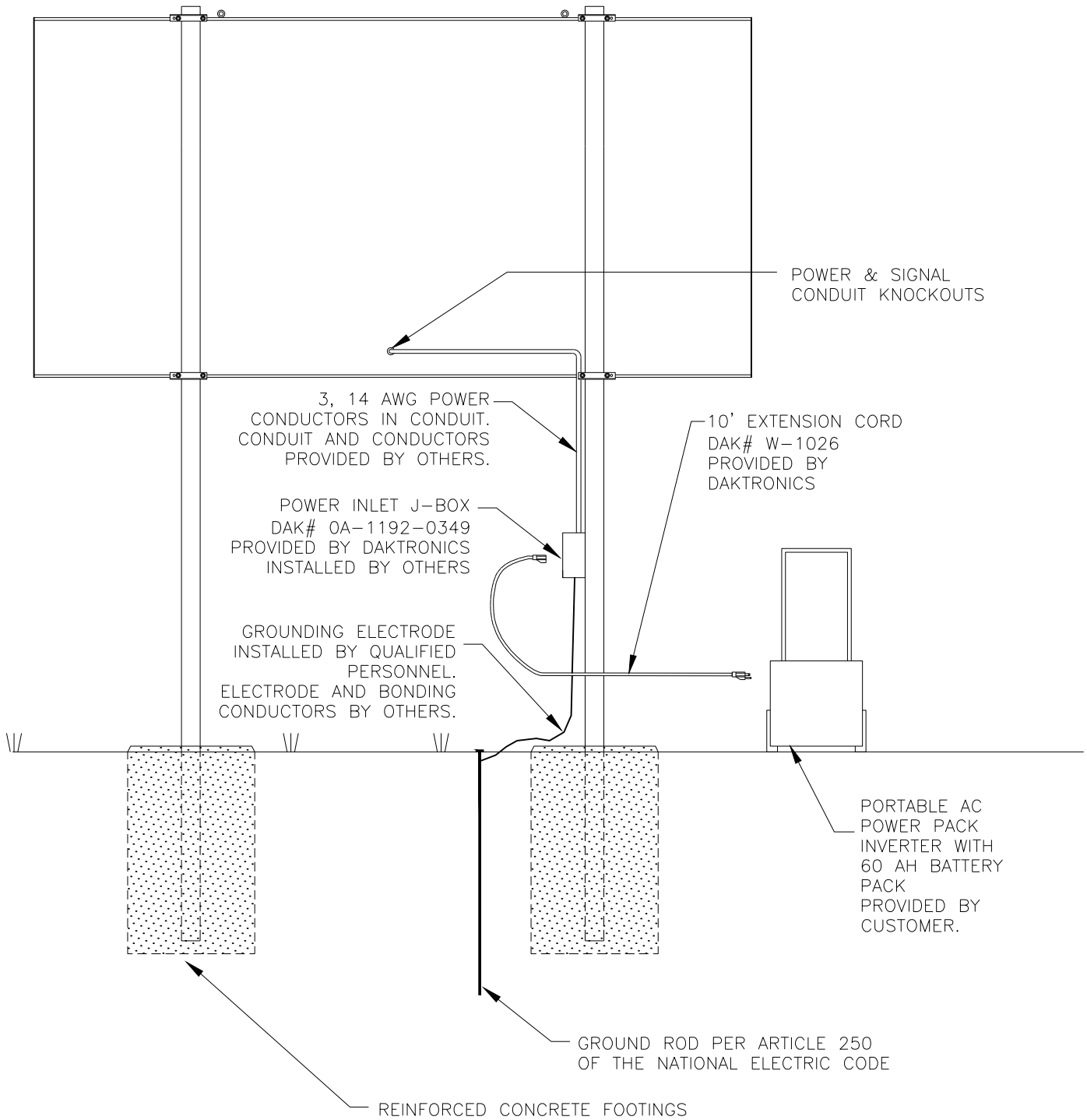

 DAKTRONICS, INC. BROOKINGS, SD 57006		THE CONCEPTS EXPRESSED AND DETAILS SHOWN ON THIS DRAWING ARE CONFIDENTIAL AND PROPRIETARY. DO NOT REPRODUCE BY ANY MEANS WITHOUT THE EXPRESSED WRITTEN CONSENT OF DAKTRONICS, INC. COPYRIGHT 2010 DAKTRONICS, INC.	
		DO NOT SCALE DRAWING	
PROJ: OUTDOOR SCOREBOARDS			
TITLE: INSTALLATION, PORTABLE POWERED SCOREBOARDS			
DESIGN: EBRAVEK		DRAWN: SBRINK	DATE: 03 DEC 10
SCALE: 1 = 40			
SHEET	REV	JOB NO:	FUNC-TYPE-SIZE
	00	1092	E-07-A
			1039104

This page intentionally left blank.

B Daktronics Warranty & Limitation of Liability

This section includes the Daktronics Warranty & Limitation of Liability statement (SL-02374).

This page intentionally left blank.

DAKTRONICS WARRANTY & LIMITATION OF LIABILITY

This Warranty and Limitation of Liability (the "Warranty") sets forth the warranty provided by Daktronics with respect to the Equipment. By accepting delivery of the Equipment, Purchaser and End User agree to be bound by and accept these terms and conditions. Unless otherwise defined herein, all terms within the Warranty shall have the same meaning and definition as provided elsewhere in the Agreement.

DAKTRONICS WILL ONLY BE OBLIGATED TO HONOR THE WARRANTY SET FORTH IN THESE TERMS AND CONDITIONS UPON RECEIPT OF FULL PAYMENT FOR THE EQUIPMENT

1. Warranty Coverage.

- A. Daktronics warrants to the original end user (the "End User", which may also be the Purchaser) that the Equipment will be free from Defects (as defined below) in materials and workmanship for a period of one (1) year (the "Warranty Period"). The Warranty Period shall commence on the earlier of: (i) four weeks from the date that the Equipment leaves Daktronics' facility; or (ii) Substantial Completion as defined herein. The Warranty Period shall expire on the first anniversary of the commencement date.

"Substantial Completion" means the operational availability of the Equipment to the End User in accordance with the Equipment's specifications, without regard to punch-list items, or other non-substantial items which do not affect the operation of the Equipment

- B. Daktronics' obligation under this Warranty is limited to, at Daktronics' option, replacing or repairing, any Equipment or part thereof that is found by Daktronics not to conform to the Equipment's specifications. Unless otherwise directed by Daktronics, any defective part or component shall be returned to Daktronics for repair or replacement. This Warranty does not include on-site labor charges to remove or install these components. Daktronics may, at its option, provide on-site warranty service. Daktronics shall have a reasonable period of time to make such replacements or repairs and all labor associated therewith shall be performed during regular working hours. Regular working hours are Monday through Friday between 8:00 a.m. and 5:00 p.m. at the location where labor is performed, excluding any holidays observed by Daktronics.
- C. Daktronics shall pay ground transportation charges for the return of any defective component of the Equipment. All such items shall be shipped by End User DDP Daktronics designated facility per Incoterms® 2020. If returned Equipment is repaired or replaced under the terms of this Warranty, Daktronics will prepay ground transportation charges back to End User and shall ship such items DDP End User's designated facility per Incoterms® 2020; otherwise, End User shall pay transportation charges to return the Equipment back to the End User and such Equipment shall be shipped Ex Works Daktronics designated facility per Incoterms® 2020. All returns must be pre-approved by Daktronics before shipment. Daktronics shall not be obligated to pay freight for any unapproved return. End User shall pay any upgraded or expedited transportation charges
- D. Any replacement parts or Equipment will be new or serviceably used, comparable in function and performance to the original part or Equipment and warranted for the remainder of the Warranty Period. Purchasing additional parts or Equipment from the Seller does not extend the Warranty Period.
- E. Defects shall be defined as follows. With regard to the Equipment (excepting LEDs), a "Defect" shall refer to a material variance from the design specifications that prohibit the Equipment from operating for its intended use. With respect to LEDs, "Defects" are defined as LED pixels that cease to emit light. Unless otherwise expressly provided, this Warranty does not impose any duty or liability upon Daktronics for partial LED pixel degradation. Notwithstanding the foregoing, in no event does this Warranty include LED pixel degradation caused by UV light. This Warranty does not provide for the replacement or installation of communication methods including but not limited to, wire, fiber optic cable, conduit, trenching, or for the purpose of overcoming local site interference radio equipment substitutions.

EXCEPT AS OTHERWISE EXPRESSLY SET FORTH IN THIS WARRANTY, TO THE MAXIMUM EXTENT PERMITTED BY APPLICABLE LAW, DAKTRONICS DISCLAIMS ANY AND ALL OTHER PROMISES, REPRESENTATIONS AND WARRANTIES APPLICABLE TO THE EQUIPMENT AND REPLACES ALL OTHER WARRANTIES OR CONDITIONS, EXPRESS OR IMPLIED, INCLUDING, BUT NOT LIMITED TO, ANY IMPLIED WARRANTIES OR CONDITIONS OF MERCHANTABILITY, FITNESS FOR A PARTICULAR PURPOSE, OR ACCURACY OR QUALITY OF DATA. OTHER ORAL OR WRITTEN INFORMATION OR ADVICE GIVEN BY DAKTRONICS, ITS AGENTS OR EMPLOYEES, SHALL NOT CREATE A WARRANTY OR IN ANY WAY INCREASE THE SCOPE OF THIS LIMITED WARRANTY.

THIS LIMITED WARRANTY IS NOT TRANSFERABLE.

2. Exclusion from Warranty Coverage

This Warranty does not impose any duty or liability upon Daktronics for any:

- A. damage occurring at any time, during shipment of Equipment unless otherwise provided for in the Agreement. When returning Equipment to Daktronics for repair or replacement, End User assumes all risk of loss or damage, agrees to use any shipping containers that might be provided by Daktronics, and to ship the Equipment in the manner prescribed by Daktronics;
- B. damage caused by: (i) the improper handling, installation, adjustment, use, repair, or service of the Equipment, or (ii) any physical damage which includes, but is not limited to, missing, broken, or cracked components resulting from non-electrical causes;

DAKTRONICS WARRANTY & LIMITATION OF LIABILITY

altered, scratched, or fractured electronic traces; missing or gauged solder pads; cuts or clipped wires; crushed, cracked, punctured, or bent circuit boards; or tampering with any electronic connections, provided that such damage is not caused by personnel of Daktronics or its authorized repair agents;

- C. damage caused by the failure to provide a continuously suitable environment, including, but not limited to: (i) neglect or misuse; (ii) improper power including, without limitation, a failure or sudden surge of electrical power; (iii) improper air conditioning, humidity control, or other environmental conditions outside of the Equipment's technical specifications such as extreme temperatures, corrosives and metallic pollutants; or (iv) any other cause other than ordinary use;
- D. damage caused by fire, flood, earthquake, water, wind, lightning or other natural disaster, strike, inability to obtain materials or utilities, war, terrorism, civil disturbance, or any other cause beyond Daktronics' reasonable control;
- E. failure to adjust, repair or replace any item of Equipment if it would be impractical for Daktronics personnel to do so because of connection of the Equipment by mechanical or electrical means to another device not supplied by Daktronics, or the existence of general environmental conditions at the site that pose a danger to Daktronics personnel;
- F. statements made about the product by any salesperson, dealer, distributor or agent, unless such statements are in a written document signed by an officer of Daktronics. Such statements as are not included in a signed writing do not constitute warranties, shall not be relied upon by End User and are not part of the contract of sale;
- G. damage arising from the use of Daktronics products in any application other than the commercial and industrial applications for which they are intended, unless, upon request, such use is specifically approved in writing by Daktronics;
- H. replenishment of spare parts. In the event the Equipment was purchased with a spare parts package, the parties acknowledge and agree that the spare parts package is designed to exhaust over the life of the Equipment, and as such, the replenishment of the spare parts package is not included in the scope of this Warranty;
- I. security or functionality of the End User's network or systems, or anti-virus software updates;
- J. performance of preventive maintenance;
- K. third-party systems and other ancillary equipment, including without limitation front-end video control systems, audio systems, video processors and players, HVAC equipment, batteries and LCD screens;
- L. incorporation of accessories, attachments, software or other devices not furnished by Daktronics; or
- M. paint or refinishing the Equipment or furnishing material for this purpose.

3. Limitation of Liability

- A. Daktronics shall be under no obligation to furnish continued service under this Warranty if alterations are made to the Equipment without the prior written approval of Daktronics.
- B. It is specifically agreed that the price of the Equipment is based upon the following limitation of liability. In no event shall Daktronics (including its subsidiaries, affiliates, officers, directors, employees, or agents) be liable for any claims asserting or based on (a) loss of use of the facility or equipment; lost business, revenues, or profits; loss of goodwill; failure or increased cost of operations; loss, damage or corruption of data; loss resulting from system or service failure, malfunction, incompatibility, or breaches in system security; or (b) any special, consequential, incidental or exemplary damages arising out of or in any way connected with the Equipment or otherwise, including but not limited to damages for lost profits, cost of substitute or replacement equipment, down time, injury to property or any damages or sums paid to third parties, even if Daktronics has been advised of the possibility of such damages. The foregoing limitation of liability shall apply whether any claim is based upon principles of contract, tort or statutory duty, principles of indemnity or contribution, or otherwise
- C. In no event shall Daktronics be liable for loss, damage, or injury of any kind or nature arising out of or in connection with this Warranty in excess of the Purchase Price of the Equipment. The End User's remedy in any dispute under this Warranty shall be ultimately limited to the Purchase Price of the Equipment to the extent the Purchase Price has been paid.

4. Assignment of Rights

- A. The Warranty contained herein extends only to the End User (which may be the Purchaser) of the Equipment and no attempt to extend the Warranty to any subsequent user-transferee of the Equipment shall be valid or enforceable without the express written consent of Daktronics.

5. Governing Law; Election of Remedies

- A. The rights and obligations of the parties under this Warranty shall not be governed by the provisions of the United Nations Convention on Contracts for the International Sales of Goods of 1980. The parties consent to the application of the laws of the State of South Dakota to govern, interpret, and enforce each of the parties' rights, duties, and obligations arising from, or relating in any manner to, the subject matter of this Warranty, without regard to conflict of law principles.
- B. Any dispute, controversy or claim arising from or related to this Warranty, the parties shall first attempt to settle through negotiations. In the event that no resolution is reached, then such dispute, controversy, or claim shall be resolved by final and binding arbitration under the Rules of Arbitration of the International Chamber of Commerce. The language of the arbitration



DAKTRONICS WARRANTY & LIMITATION OF LIABILITY

shall be English. The place of the arbitration shall be Sioux Falls, SD. A single arbitrator selected by the parties shall preside over the proceeding. If a single arbitrator cannot be agreed upon by the parties, each party shall select an arbitrator, and those arbitrators shall confer and agree on the appointed arbitrator to adjudicate the arbitration. The arbitrator shall have the power to grant any provisional or final remedy or relief that it deems appropriate, including conservatory measures and an award of attorneys' fees. The arbitrator shall make its decisions in accordance with applicable law. By agreeing to arbitration, the Parties do not intend to deprive any court of its jurisdiction to issue a pre-arbitral injunction, pre-arbitral attachment, or other order in aid of arbitration proceedings and the enforcement of any award. Without prejudice to such provisional remedies as may be available under the jurisdiction of a court, the arbitrator shall have full authority to grant provisional remedies and to direct the Parties to request that any court modify or vacate any temporary or preliminary relief issued by such court, and to award damages for the failure of any Party to respect the arbitrator's orders to that effect.

6. Availability of Extended Service Agreement

- A. For End User's protection, in addition to that afforded by the warranties set forth herein, End User may purchase extended warranty services to cover the Equipment. The Extended Service Agreement, available from Daktronics, provides for electronic parts repair and/or on-site labor for an extended period from the date of expiration of this warranty. Alternatively, an Extended Service Agreement may be purchased in conjunction with this Warranty for extended additional services. For further information, contact Daktronics Customer Service at 1-800-DAKTRONics (1-800-325-8766).

Additional Terms applicable to sales outside of the United States

The following additional terms apply **only** where the installation site of the Equipment is located outside of the United States of America.

- In the event that the installation site of the Equipment is in a country other than the U.S.A., then, notwithstanding Section 5 of the Warranty, where the selling entity is the entity listed in Column 1, then the governing law of this Warranty is the law of the jurisdiction listed in the corresponding row in Column 2 without regard to its conflict of law principles. Furthermore, if the selling entity is an entity listed in Column 1, then the place of arbitration is listed in the corresponding row in Column 3.

Column 1 (Selling Entity)	Column 2 (Governing Law)	Column 3 (Location of Arbitration)
Daktronics, Inc.	The state of Illinois	Chicago, IL, U.S.A.
Daktronics Canada, Inc.	The Province of Ontario, Canada	Toronto, Ontario, Canada
Daktronics UK Ltd.	England and Wales	Bristol, UK
Daktronics GmbH	The Federal Republic of Germany	Wiesbaden, Germany
Daktronics Hong Kong Limited	Hong Kong, Special Administrative Region of the P.R.C.	Hong Kong SAR
Daktronics Shanghai Co., Ltd.	The Peoples Republic of China	Shanghai, P.R.C.
Daktronics France, SARL	France	Paris, France
Daktronics Japan, Inc.	Japan	Tokyo, Japan
Daktronics International Limited	Macau, Special Administrative Region of the P.R.C.	Macau SAR
Daktronics Australia Pad Ltd	Australia	Sydney, Australia
Daktronics Singapore Pte. Ltd	Singapore	Singapore
Daktronics Brazil LTDA	Brazil	São Paulo, Brazil
Daktronics Spain S.L.U.	Spain	Madrid, Spain
Daktronics Belgium N. V	Belgium	Kruikeke, Belgium
Daktronics Ireland Co. Ltd.	Ireland	Dublin, Ireland

This page intentionally left blank.