

**RTN-301 SERIES**  
DAKT-0203-00  
DISPLAY MANUAL  
P2094

DD3936012  
Rev 03  
22 November 2022

## FCC Statement

### Supplier Declaration of Conformity (SDoC)

This product complies with Part 15 of the FCC Rules. Operation is subject to the following two conditions: (1) This device may not cause harmful interference, and (2) this device must accept any interference received, including interference that may cause undesired operation.

**Note:** This equipment has been tested and found to comply with the limits for a Class A digital device, pursuant to part 15 of the FCC Rules. These limits are designed to provide reasonable protection against harmful interference when the equipment is operated in a commercial environment. This equipment generates, uses, and can radiate radio frequency energy and, if not installed and used in accordance with the instruction manual, may cause harmful interference to radio communications. Operation of this equipment in a residential area is likely to cause harmful interference in which case the user will be required to correct the interference at their own expense.

**Warning:** The user is cautioned that changes and modifications made to the equipment without the approval of manufacturer could void the user's authority to operate this equipment.

## Industry Canada Regulatory Information

This Class A digital apparatus complies with Canadian ICES-003.

Cet appareil numérique de la classe A est conforme à la norme NMB-003 du Canada.

## Inquiries

Contact Daktronics with any questions regarding our product compliance.

### Mail:

Daktronics  
201 Daktronics Dr.  
Brookings, SD 57006 USA

### Phone:

800-325-8766

### Website:

[www.daktronics.com](http://www.daktronics.com)



**DAKTRONICS**

### Copyright © 2022

All rights reserved. While every precaution has been taken in the preparation of this manual, the publisher assumes no responsibility for errors or omissions. No part of this book covered by the copyrights hereon may be reproduced or copied in any form or by any means—graphic, electronic, or mechanical, including photocopying, taping, or information storage and retrieval systems—without written permission of the publisher.

*Daktronics trademarks are property of Daktronics, Inc. All other trademarks are property of their respective companies.*

# Table of Contents

- 1 Introduction.....1**
  - How to Use This Manual .....1
  - Numbering Conventions.....1
    - Drawing Number** .....1
    - Part Number** .....1
    - Module Number** .....2
    - Model Number**.....2
  - Important Safeguards .....2
- 2 Warnings/Disclaimers.....3**
  - Display .....3
  - Structure.....3
- 3 Glossary .....5**
- 4 Replacement Parts .....7**
  - Replacement Parts List.....7
  - Daktronics Exchange and Repair & Return Programs .....7
    - Exchange Program** .....7
    - Repair & Return Program** .....8
    - Shipping Address**.....8
  - Warranty & Limitation of Liability.....9
- A Reference Documents .....11**
- B Reference Drawings .....13**
- C Daktronics Warranty & Limitation of Liability .....15**

*This page intentionally left blank.*

# 1 Introduction

## How to Use This Manual

This manual explains the installation, maintenance, and troubleshooting of this ribbon display system. For additional information regarding the safety, installation, operation, and service of this system, refer to the telephone numbers listed in **Daktronics Exchange and Repair & Return Programs (p.7)**. This manual contains only generic installation topics and is not specific to a particular installation. Contract-specific information takes precedence over any general information found in this manual.

Daktronics identifies manuals by the DD number located on the cover page of each manual. For example, this manual would be referred to as **DD3936012**.

## Numbering Conventions

### Drawing Number

**Figure 1** illustrates a Daktronics drawing label. This manual refers to drawings by listing the last set of digits. In the example, the drawing would be referred to as **DWG-3929851**.

All references to drawing numbers, appendices, figures, or other manuals are presented in bold typeface, as shown in the example below:

Refer to **DWG-3929851** in **Appendix B: Reference Drawings (p.13)** for the locations of internal display components.

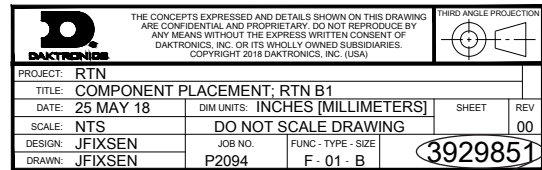

**Figure 1:** Drawing Label

### Part Number

Most display components within a display carry a white label that lists the part number. The component part number uses the following format: 0A-XXXX-XXXX (multi-component assembly) or 0P-XXXX-XXXX (display interface board). **Daktronics Exchange and Repair & Return Programs (p.7)** contains the Daktronics Exchange Policy as well as the Repair & Return Program.

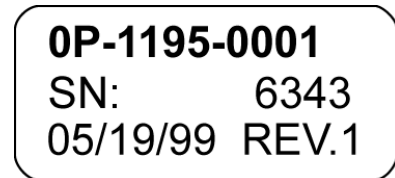

**Figure 2:** Typical Label

Refer to these instructions if any display components need replacing or repairing. **Figure 2** illustrates a typical label. The part number is in bold.

Part Type	Part Example	Part Number
Assembly	Display interface board and its mounting plate or bracket	0A-XXXX-XXXX
Individual display interface board	ProLink Router (PLR)	0P-XXXX-XXXX
Wire or cable	SATA cable	W-XXXX

## Module Number

**Figure 3** explains the module labeling method in more detail, and **Figure 4** illustrates how Daktronics numbers modules on a ribbon display.

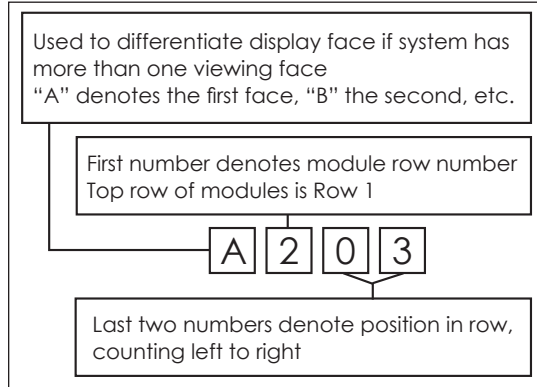

**Figure 3:** Module Number Breakdown



**Figure 4:** Module Number

## Model Number

Each display system has a model number that explains the display specifications.

RTN-301-10/15MN-HHHxWWW		
RTN-301	=	Product series
10/15MN	=	Pixel pitch/layout
HHH	=	Matrix height
WWW	=	Matrix width

## Important Safeguards

- Read and understand the installation instructions before beginning the installation process.
- Do not drop the control equipment or allow it to get wet.
- Do not disassemble the control equipment or electronic controls of the display; failure to follow this safeguard will make the warranty null and void.
- Disconnect the display power when not in use or when servicing.
- Disconnect the display power before servicing the power supplies to avoid electrical shock. The power supplies run on high voltage and may cause physical injury if touched while powered.

## 2 Warnings/Disclaimers

Review the reference documents and drawings in **Appendix A: Reference Documents (p.11)** and **Appendix B: Reference Drawings (p.13)** prior to installation as well as during the installation process.

### Display

Daktronics engineering staff must approve any changes that may affect the strength or protective integrity of the display frame or enclosures. If any modifications of this nature are made, detailed drawings of the change(s) must be submitted to Daktronics engineering staff for evaluation and approval, or the warranty will be null and void.

Displays must be lifted appropriately to ensure the display sections will not be damaged.

It is the installer's responsibility to ensure the installation meets all local codes and standards. All hardware processes used during display installation must meet the approved, stamped drawings from a professional engineer.

This display is intended to be installed in accordance with the requirements of Article 600 of the National Electrical Code and/or other applicable local codes. This includes proper grounding and bonding of the sign. A disconnect device shall be provided by the contractually obligated party for installation of the equipment.

Only qualified individuals should access the electrical components of this display and its associated equipment.

- Ensure that all electrical work meets or exceeds all local or national electrical codes.
- Provide the required power to the display as listed on the product labels, specifications, or site-specific riser drawings. The conductor size may vary based on the length of the power run.
- Consider implementing a separate circuit for the display using an isolation transformer or dedicated transformer.
- Daktronics assumes no liability for any issues caused by line voltage fluctuations or other improper power conditions.

### Structure

It is the installer's responsibility to ensure the mounting structure and hardware are built per the stamped engineering drawings and are capable of supporting the display prior to beginning the installation.

*This page intentionally left blank.*

## 3 Glossary

**Lanyard attachment ring:** a ring found on the back of each module. The lanyard attaches to the ring to keep the module from falling to the ground.

**Latch release:** a device that holds the module firmly to the display frame. There are two per module, one on the top and one on the bottom.

**Light emitting diode (LED):** a low energy, high intensity lighting unit.

**Line filter:** a device that removes electromagnetic noise from the power system to avoid interference with local communications channels. Line filters sometimes mount on brackets with power supplies. Other times they may mount alone on a bracket.

**Louver:** a plastic shade positioned horizontally above each pixel row. Louvers increase the contrast level on the display face and direct LED light for easier viewing.

**Module:** a display board with LEDs, a driver board or logic card, a black plastic housing, and a module latch assembly. Each module is individually removable from either the front or the rear of the display.

**Module latch:** a latch that stretches across the top of the module and is accessible from either the front or the rear.

**Pixel:** the smallest single point of light on a display that can be turned on and off. For LED displays, a pixel is the smallest block of light emitting devices that can generate all available colors.

**Power supply:** a device that converts AC line voltage from the termination panel to low DC voltage for one or more module driver boards. One power supply may power multiple modules.

**ProLink Router (PLR):** a display interface board that passes display data from the control system to modules and other PLRs. The ratio of PLRs to modules varies with display application.

**Termination block:** an electrical point usually used to connect internal power and signal wires to wires of the same type coming into the display from an external source.

**Video Image Processor (VIP):** an interface that drives video to the display while also dimming, providing gamma and color controls, and displaying test patterns.

*This page intentionally left blank.*

## 4 Replacement Parts

### Replacement Parts List

Most display components have a white label that lists the part number in bold. Refer to **Part Numbers (p.1)** for information on how to read the part number. Part numbers may also appear on illustrations and reference drawings as well as in the Bill of Materials (BOM) for the project. If a replacement part cannot be identified, contact Daktronics Customer Service. The following is a list of components that are commonly replaced: PLR (ProLink Router) and power supply.

### Daktronics Exchange and Repair & Return Programs

To serve customers' repair and maintenance needs, Daktronics offers both an Exchange Program and a Repair & Return Program.

#### Exchange Program

Daktronics unique Exchange Program is a quick service for replacing key parts in need of repair. If a part requires repair or replacement, Daktronics sends the customer a replacement, and the customer sends the defective part to Daktronics. This decreases display downtime.

Before contacting Daktronics, identify these important part numbers:

Display Serial Number: \_\_\_\_\_

Display Model Number: \_\_\_\_\_

Contract Number: \_\_\_\_\_

Installation Date: \_\_\_\_\_

Sign Location: \_\_\_\_\_

Daktronics Customer ID Number: \_\_\_\_\_

To participate in the Exchange Program, follow these steps:

#### 1. Call Daktronics Customer Service.

Market Description	Customer Service Number
Schools (primary through community/junior colleges), religious organizations, municipal clubs, and community centers	877-605-1115
Universities and professional sporting events, live events for auditoriums, and arenas	866-343-6018
Financial institutions, petroleum, sign companies, gaming, and wholesale/retails establishments	866-343-3122
Department of Transportation, mass transits, airports, and parking facilities	800-833-3157

**2. Mail the old part to Daktronics when the new exchange part is received.**

If the replacement part fixes the problem, send in the problem part which is being replaced.

- a. Package the old part in the same shipping materials in which the replacement part arrived.
- b. Fill out and attach the enclosed UPS shipping document.
- c. Ship the part to Daktronics.

Daktronics will charge for the replacement part immediately, unless a qualifying service agreement is in place. In most cases, the replacement part will be invoiced at the time it is shipped.

**3. Return the part within 30 working days if the replacement part does not solve the problem, or Daktronics will charge the full purchase price.**

If the part is still defective after the exchange is made, please contact Daktronics Customer Service immediately. Daktronics expects immediate return of an exchange part if it does not solve the problem. Daktronics also reserves the right to refuse parts that have been damaged due to acts of nature or causes other than normal wear and tear.

## **Repair & Return Program**

For items not subject to exchange, Daktronics offers a Repair & Return Program. To send a part for repair, follow these steps:

**1. Call Daktronics Customer Service.**

Refer to the telephone number listed on the previous page.

**2. Receive a Return Materials Authorization (RMA) number before shipping.**

Refer to the telephone number listed on the previous page.

**3. Package and pad the item carefully to prevent damage during shipping.**

Electronic components, such as printed circuit boards, should be placed in an antistatic bag before boxing. Daktronics does not recommend packing peanuts when shipping.

**4. Enclose the following information:**

- Name
- Address
- Phone number
- RMA number
- Clear description of symptoms

## **Shipping Address**

Daktronics Customer Service  
600 E 54<sup>th</sup> St N  
Sioux Falls, SD 57104  
Case #

## Warranty & Limitation of Liability

The Daktronics Warranty & Limitation of Liability statement is located in **Appendix C: Daktronics Warranty & Limitation of Liability (p.15)**. The warranty is independent of extended service agreements and is the authority in matters of service, repair, and display operation.

*This page intentionally left blank.*

## **A Reference Documents**

Use the following documents in the order listed:

- **RTN-301 Series Mounting Structure Placement & Verification Quick Guide (DD3958784)**
- **RTN-301 Series Section Crating Quick Guide (DD3963029)**
- **RTN-301 Series Section Weights & Lifting Quick Guide (DD3958389)**
- **RTN-301 Series Section Basics Quick Guide (DD3956753)**
- **RTN-301 Series Installation & Service Quick Guide (DD3963103)**
- **RTN-301 Series Border Installation Quick Guide (DD3956259)**

The images in this document may reflect exaggerated sizes for better comprehension.

It is the installer's responsibility to ensure the installation meets all local codes and standards. All hardware processes used during display installation must meet the approved, stamped drawings from a professional engineer.

## Site Overview

During the site overview, a contractor surveys for as-built conditions of the structure or mounting location through the following procedures:

- Measuring for elevation differences
- Measuring for structural dimensions
- Checking for variation in the face location
- Scanning the concrete fascia for rebar locations (recommended)

After completing the initial site survey, the installer compares the results to the contract-specific Shop Drawing. If any variations or discrepancies exist between the plan dimensions and the site survey, contact the project manager and the general contractor for the best course of action.

It is the installer's responsibility to ensure the mounting structure and hardware are built per the stamped engineering drawings and are capable of supporting the display. Daktronics is not responsible for mounting decisions made by others.

**Figure 1** illustrates a front view of a typical display layout that is linearly scalable with all available section sizes, and **Figure 2** illustrates a front view of a typical wall support structure. Refer to the supplied display section layout documentation for dimensions ( $X_{ix}$ ) and ( $Y_{ix}$ ), to the **RTN-301 Series Section Lifting Quick Guide (DD3958389)** for available section sizes, and to the contract-specific Shop Drawing for horizontal wall clip locations.

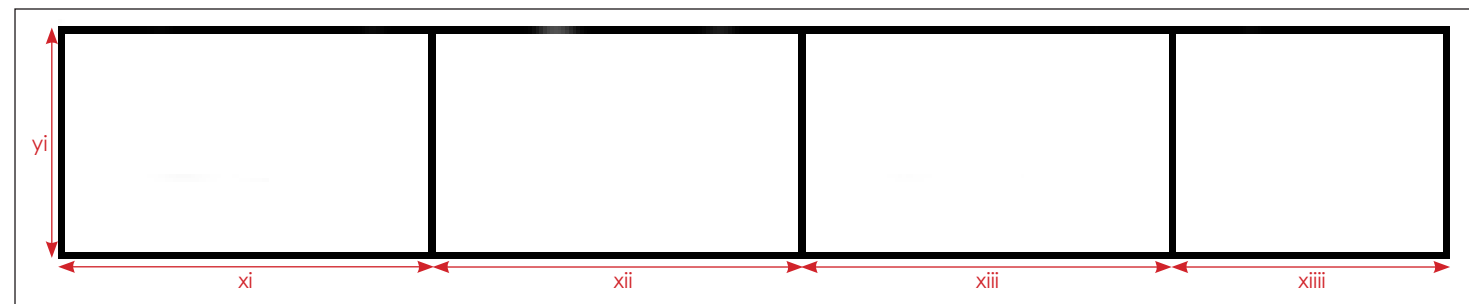

Figure 1: Typical Display Layout (Front View)

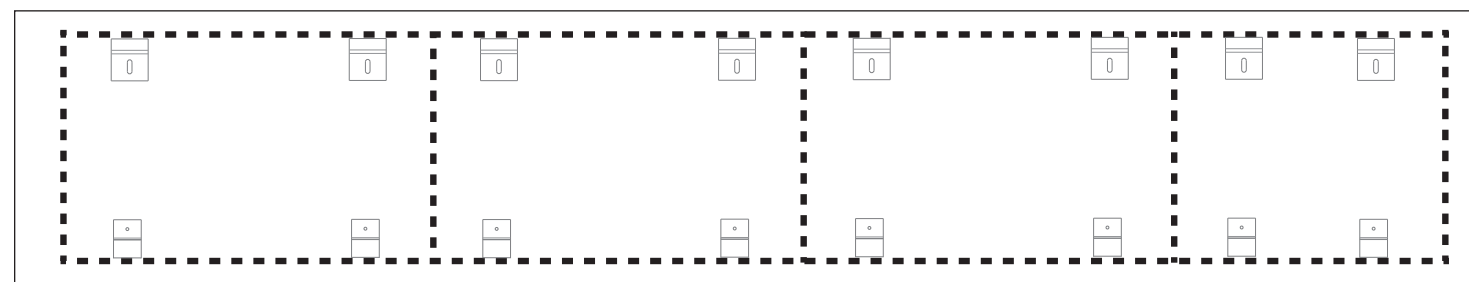

Figure 2: Typical Wall Support Structure with Display Overlay

## Verification

Ensure the upper wall clips are level across the entire fascia as shown in **Figure 3**. To ensure proper anchor embedment, upper wall clips *cannot* be shimmed on the fascia face. Lower Z-clips can be shimmed on the fascia face, but shimming must be approved by the project team prior to installation. Any shimming must be done on the cabinet clips.

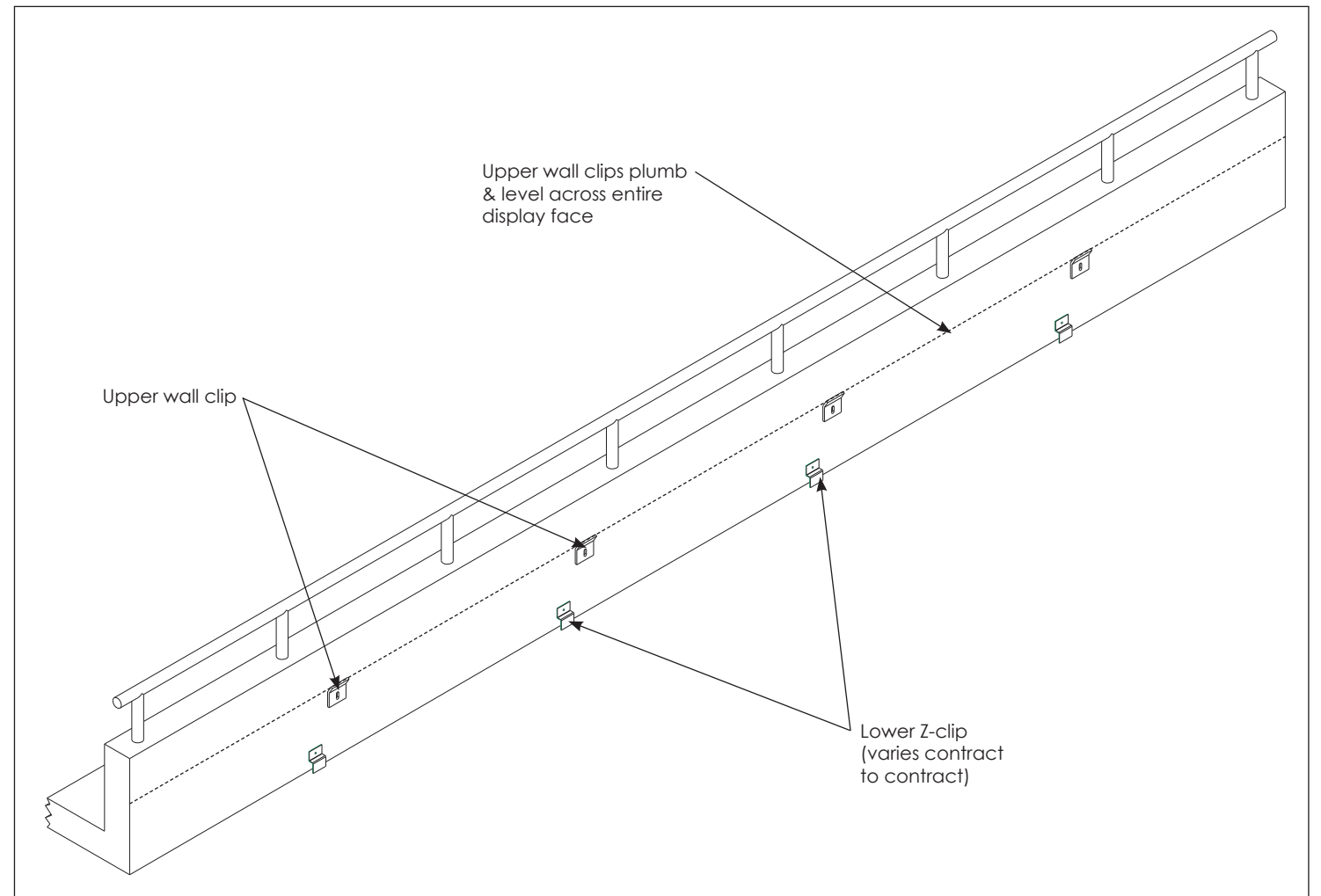

Figure 3: Level Upper Wall Clips

## Lift

1. Use either a forklift or a crane to lift the shipping frames. For single frames, lift from either the forklift pockets with a forklift or from the supplied lift points on the end of the frame with a crane/straps or a spreader beam.

For stacked frames, lift from either the forklift pockets on the top frame with a forklift or from the supplied lift points on the end of the frame with a crane/straps or a spreader beam.

Do not forklift stacked frames from the bottom frame, as this is unstable and could result in serious injury to the operator and/or damage to the product. Refer to **Figure 1**.

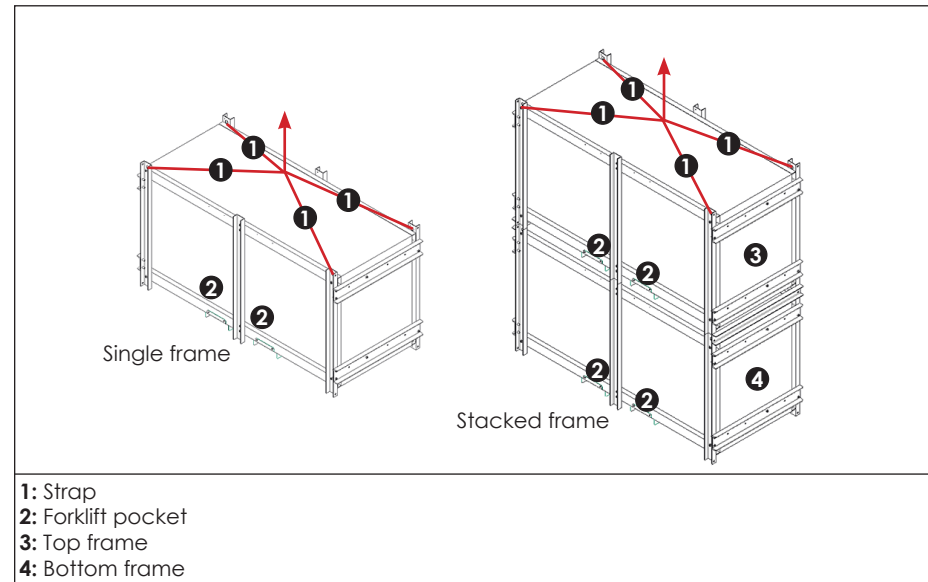

Figure 1: Lift Methods

2. Ensure the straps are at a minimum 45° angle or greater if using a crane/straps to lift the frames. Refer to **Figure 2**.

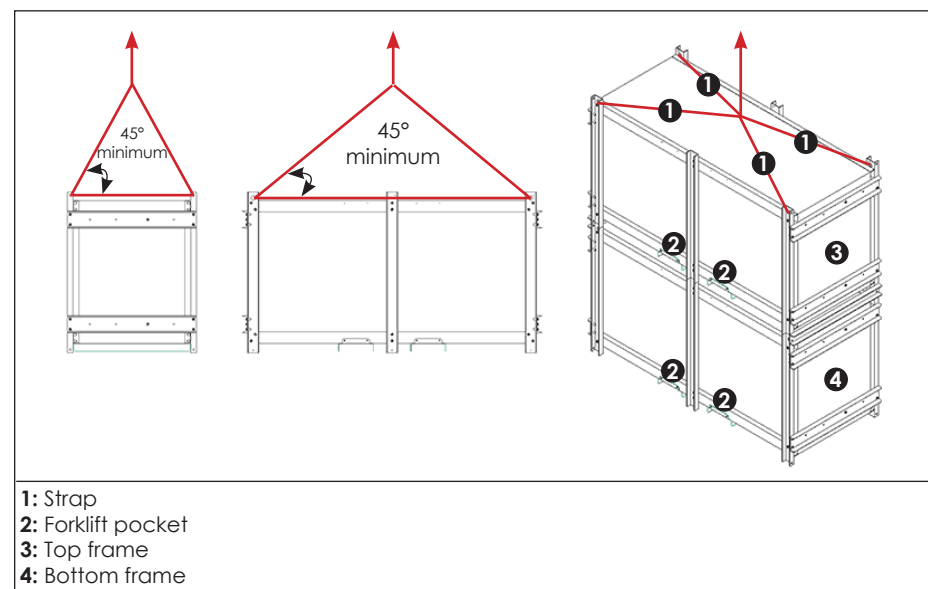

Figure 2: Strap Angle (Front & Side View)

## Disassemble

1. Remove the M12 hardware from the stacked frame support brackets on the frames to separate the top and bottom frames (if applicable). Unstack the frames and remove the stretch wrap and the top horizontal runners from the frames. Refer to **Figure 3**.

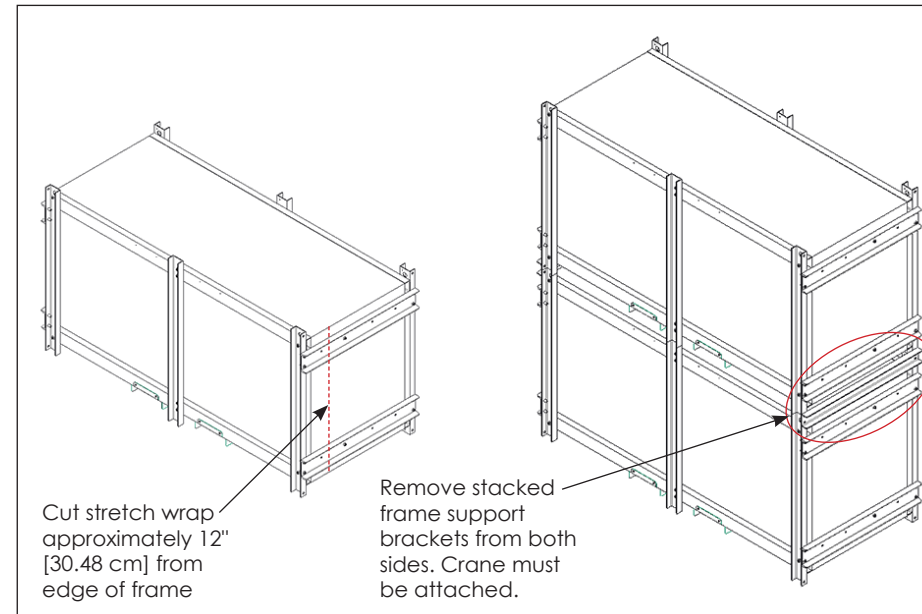

Figure 3: Separate and Unstack Frames

2. Use the hex security bit (Daktronics part number TH-1170) supplied in the toolkit to unlatch the beverage shroud. Flip the beverage shroud open and insert lift eyes in the top of the first display section. Refer to the **RTN-301 Series Section Basics Quick Guide (DD3956753)**. Attach the crane to the lift points. Refer to **Figure 4** for the section lift order and to **Figure 5** for proper configurations.

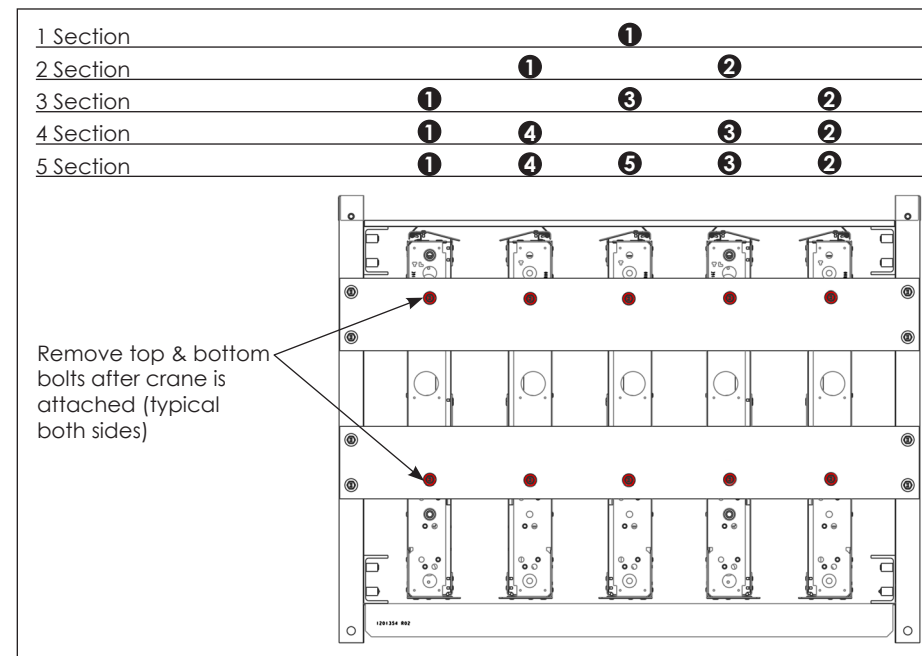

Figure 4: Section Lift Order (Front View)

## Stabilize

Figure 5 shows stable and unstable configurations.

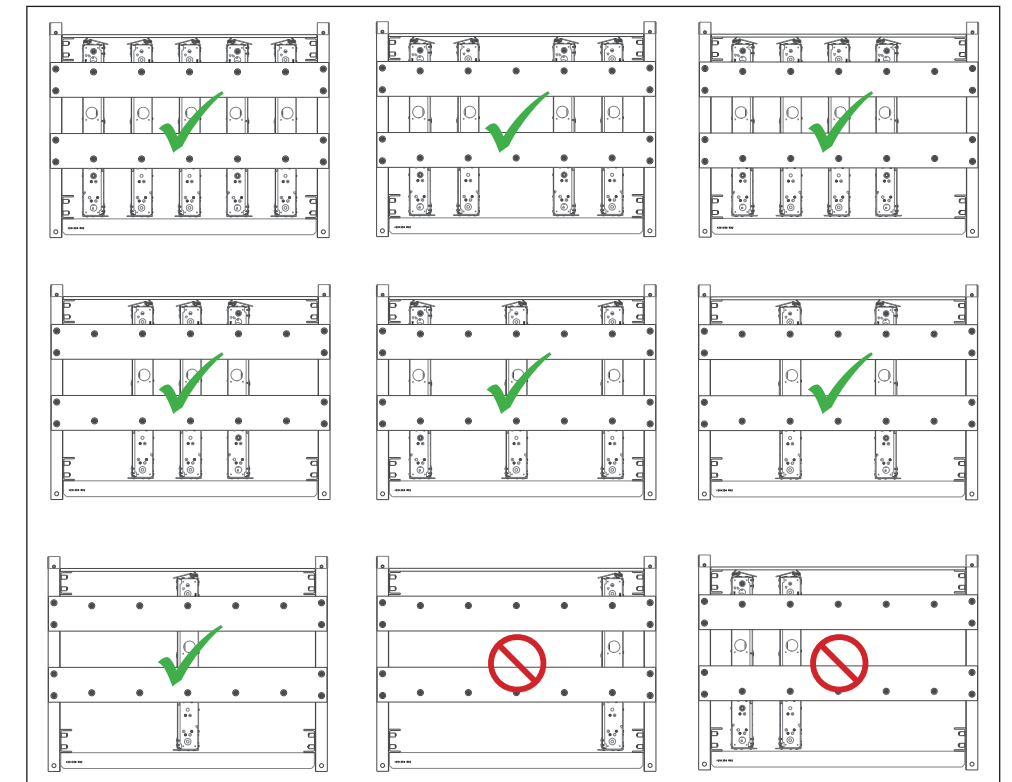

Figure 5: Stable vs. Unstable Crate Configurations (Side View)

### Stable Configurations

- Any four or five sections
- Three middle sections
- One outside section on each side and one center section
- Two outside sections
- One center section

### Unstable Configurations

- Two sections on one side
- Any single section in the outer locations

Primary Lifting Connection

Display Width	Lift Eye Location X	Lift Eye Spacing Y	Minimum Cable Length L
4-Wide Display	19.68" [500 mm]	19.68" [500 mm]	14" [356 mm]
5-Wide Display	19.68" [500 mm]	19.68" [500 mm]	28" [71 mm]
6-Wide Display	19.68" [500 mm]	19.68" [500 mm]	42" [1067 mm]
6-Wide Display	19.68" [500 mm]	19.68" [500 mm]	56" [1422 mm]
4-Wide Wing	19.68" [500 mm]	39.37" [1000 mm]	14" [356 mm]
5-Wide Wing	19.68" [500 mm]	39.37" [1000 mm]	28" [71 mm]
6-Wide Wing	19.68" [500 mm]	39.37" [1000 mm]	42" [1067 mm]

Lift Eyes

M12 lift eyes are supplied with the installation hardware. Lift eyes should be installed with the hole parallel to the display face as shown in **Figure 1**. The beverage shroud must be opened or removed to access the lift eye locations.

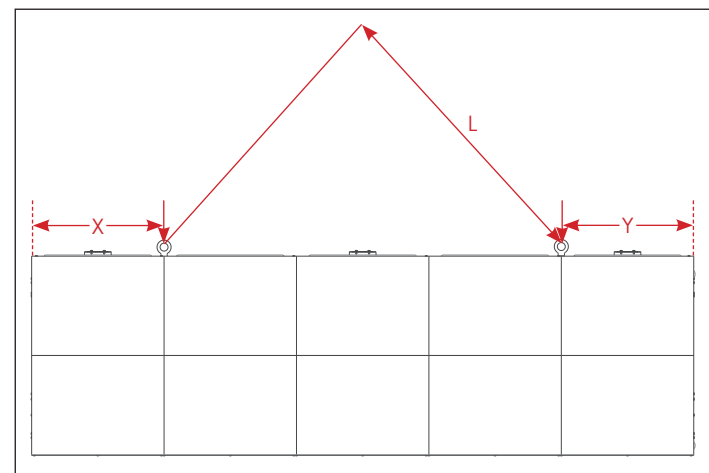

Figure 1: Lift Eye Locations (Beverage Shroud Removed)

Acceptable Lifting Methods

Recommended Method

- Use a spreader beam with sufficient weight capacity. Refer to **Figure 2** and **Section Sizes & Weight Estimates (p.1)**.
- Connect to both lift eye locations.
- Lift displays one section at a time.

Alternate Method

This method is not approved for ProRail® applications.

- Use chains, cables, or straps with sufficient weight capacity, accounting for increased loads from the rigging angle. Refer to **Figure 3** and **Section Sizes & Weight Estimates (p.1)**.
- Lift at a maximum angle of 45° from vertical. Refer to **Figure 3**.

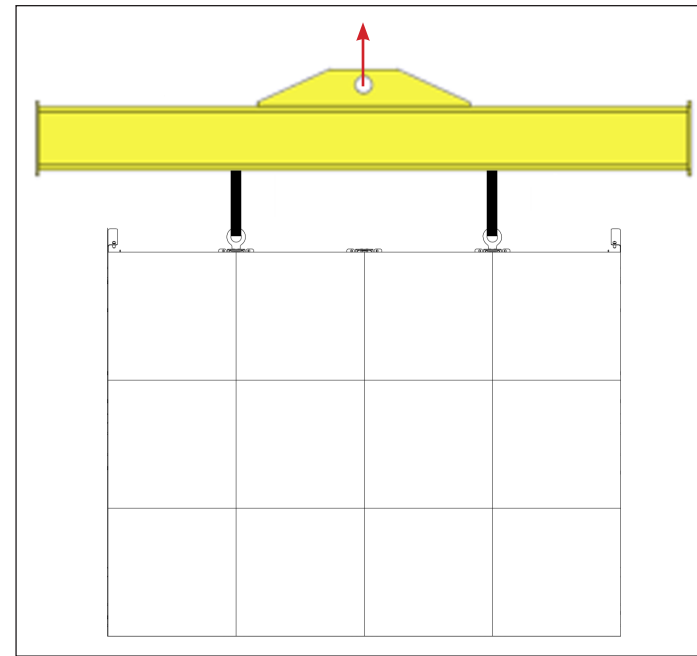

Figure 2: Lift with Spreader Beam

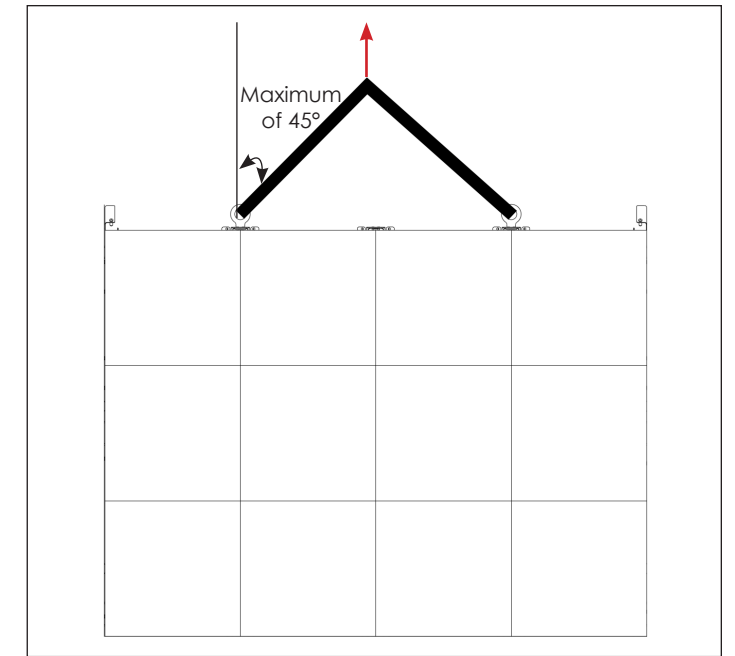

Figure 3: Lift with Chains

Section Sizes & Weight Estimates

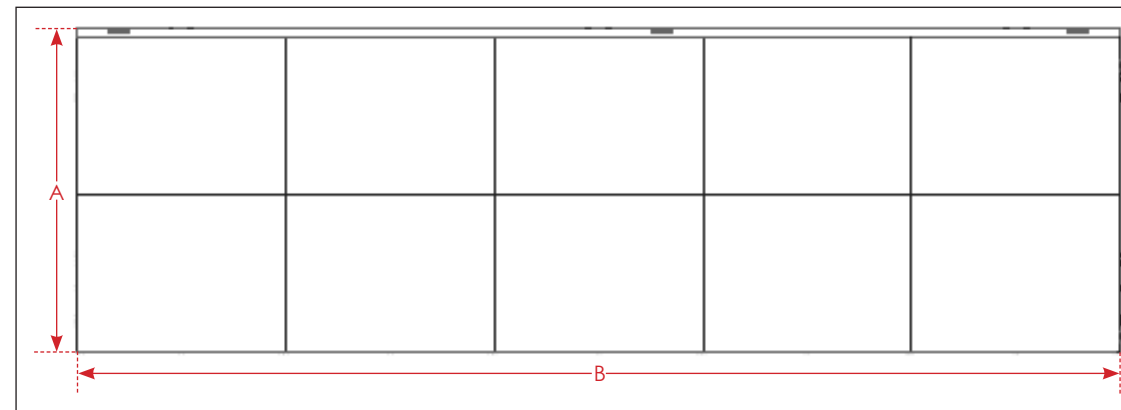

Figure 4: Front View

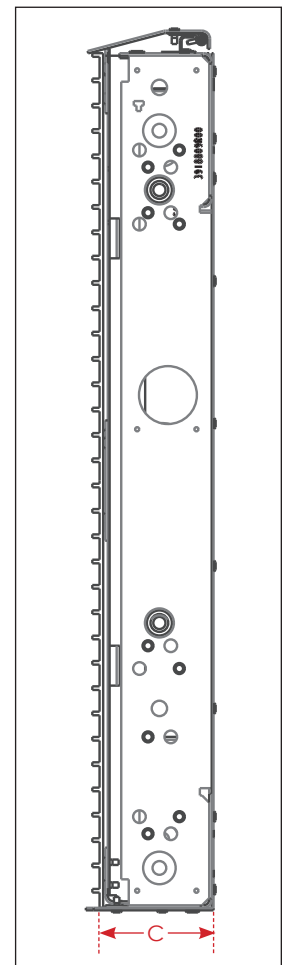

Figure 5: Side View

Modules High x Modules Wide	Estimated Weight	Active Area	Overall Height A	Overall Width B	Overall Depth C
1T-1S (1 Tall-1 Short) x 3	38 lbs [17 kg]	24.625" [625 mm] x 59.062" [1500 mm]	25.5" [647 mm]	59.062" [1500 mm]	4.4" [112 mm]
1T-1S (1 Tall-1 Short) x 4	49 lbs [22 kg]	24.625" [625 mm] x 78.75" [2000 mm]	25.5" [647 mm]	78.75" [2000 mm]	4.4" [112 mm]
1T-1S (1 Tall-1 Short) x 5	59 lbs [27 kg]	24.625" [625 mm] x 98.438" [2500 mm]	25.5" [647 mm]	98.438" [2500 mm]	4.4" [112 mm]
1T-1S (1 Tall-1 Short) x 6	69 lbs [31 kg]	24.625" [625 mm] x 118.125" [3000 mm]	25.5" [647 mm]	118.125" [3000 mm]	4.4" [112 mm]
2Tx3 (2 Tall) x 3	41 lbs [19 kg]	29.5" [750 mm] x 59.062" [1500 mm]	30.375" [772 mm]	59.062" [1500 mm]	4.4" [112 mm]
2Tx4 (2 Tall) x 4	53 lbs [24 kg]	29.5" [750 mm] x 78.75" [2000 mm]	30.375" [772 mm]	78.75" [2000 mm]	4.4" [112 mm]
2Tx5 (2 Tall) x 5	64 lbs [29 kg]	29.5" [750 mm] x 98.438" [2500 mm]	30.375" [772 mm]	98.438" [2500 mm]	4.4" [112 mm]
2Tx6 (2 Tall) x 6	75 lbs [34 kg]	29.5" [750 mm] x 118.125" [3000 mm]	30.375" [772 mm]	118.125" [3000 mm]	4.4" [112 mm]
3Sx3 (3 Short) x 3	43 lbs [20 kg]	29.5" [750 mm] x 59.062" [1500 mm]	30.375" [772 mm]	59.062" [1500 mm]	4.4" [112 mm]
3Sx4 (3 Short) x 4	55 lbs [25 kg]	29.5" [750 mm] x 78.75" [2000 mm]	30.375" [772 mm]	78.75" [2000 mm]	4.4" [112 mm]
3Sx5 (3 Short) x 5	67 lbs [30 kg]	29.5" [750 mm] x 98.438" [2500 mm]	30.375" [772 mm]	98.438" [2500 mm]	4.4" [112 mm]
3Sx6 (3 Short) x 6	79 lbs [36 kg]	29.5" [750 mm] x 118.125" [3000 mm]	30.375" [772 mm]	118.125" [3000 mm]	4.4" [112 mm]
1T-2Sx3 (1 Tall-2 Short) x 3	46 lbs [21 kg]	34.438" [875 mm] x 59.062" [1500 mm]	35.313" [897 mm]	59.062" [1500 mm]	4.4" [112 mm]
1T-2S (1 Tall-2 Short) x 4	59 lbs [27 kg]	34.438" [875 mm] x 78.75" [2000 mm]	35.313" [897 mm]	78.75" [2000 mm]	4.4" [112 mm]
1T-2S (1 Tall-2 Short) x 5	72 lbs [33 kg]	34.438" [875 mm] x 98.438" [2500 mm]	35.313" [897 mm]	98.438" [2500 mm]	4.4" [112 mm]
1T-2S (1 Tall-2 Short) x 6	85 lbs [39 kg]	34.438" [875 mm] x 118.125" [3000 mm]	35.313" [897 mm]	118.125" [3000 mm]	4.4" [112 mm]
1T-1S (1 Tall-1 Short) x 4 Wing	54 lbs [24 kg]	24.625" [625 mm] x 78.75" [2000 mm]	25.5" [647 mm]	78.75" [2000 mm]	4.4" [112 mm]
1T-1S (1 Tall-1 Short) x 5 Wing	65 lbs [29 kg]	24.625" [625 mm] x 98.438" [2500 mm]	25.5" [647 mm]	98.438" [2500 mm]	4.4" [112 mm]
1T-1S (1 Tall-1 Short) x 6 Wing	76 lbs [35 kg]	24.625" [625 mm] x 118.125" [3000 mm]	25.5" [647 mm]	118.125" [3000 mm]	4.4" [112 mm]
2T (2 Tall) x 4 Wing	49 lbs [22 kg]	29.5" [750 mm] x 78.75" [2000 mm]	30.375" [772 mm]	78.75" [2000 mm]	4.4" [112 mm]
2T (2 Tall) x 5 Wing	60 lbs [27 kg]	29.5" [750 mm] x 98.438" [2500 mm]	30.375" [772 mm]	98.438" [2500 mm]	4.4" [112 mm]
2T (2 Tall) x 6 Wing	70 lbs [32 kg]	29.5" [750 mm] x 118.125" [3000 mm]	30.375" [772 mm]	118.125" [3000 mm]	4.4" [112 mm]
3S (3 Short) x 4 Wing	56 lbs [25 kg]	29.5" [750 mm] x 78.75" [2000 mm]	30.375" [772 mm]	78.75" [2000 mm]	4.4" [112 mm]
3S (3 Short) x 5 Wing	68 lbs [31 kg]	29.5" [750 mm] x 98.438" [2500 mm]	30.375" [772 mm]	98.438" [2500 mm]	4.4" [112 mm]
3S (3 Short) x 6 Wing	79 lbs [36 kg]	29.5" [750 mm] x 118.125" [3000 mm]	30.375" [772 mm]	118.125" [3000 mm]	4.4" [112 mm]
1T-2S (1 Tall-2 Short) x 4 Wing	60 lbs [27 kg]	34.438" [875 mm] x 78.75" [2000 mm]	35.313" [897 mm]	78.75" [2000 mm]	4.4" [112 mm]
1T-2S (1 Tall-2 Short) x 5 Wing	73 lbs [33 kg]	34.438" [875 mm] x 98.438" [2500 mm]	35.313" [897 mm]	98.438" [2500 mm]	4.4" [112 mm]
1T-2S (1 Tall-2 Short) x 6 Wing	86 lbs [39 kg]	34.438" [875 mm] x 118.125" [3000 mm]	35.313" [897 mm]	118.125" [3000 mm]	4.4" [112 mm]

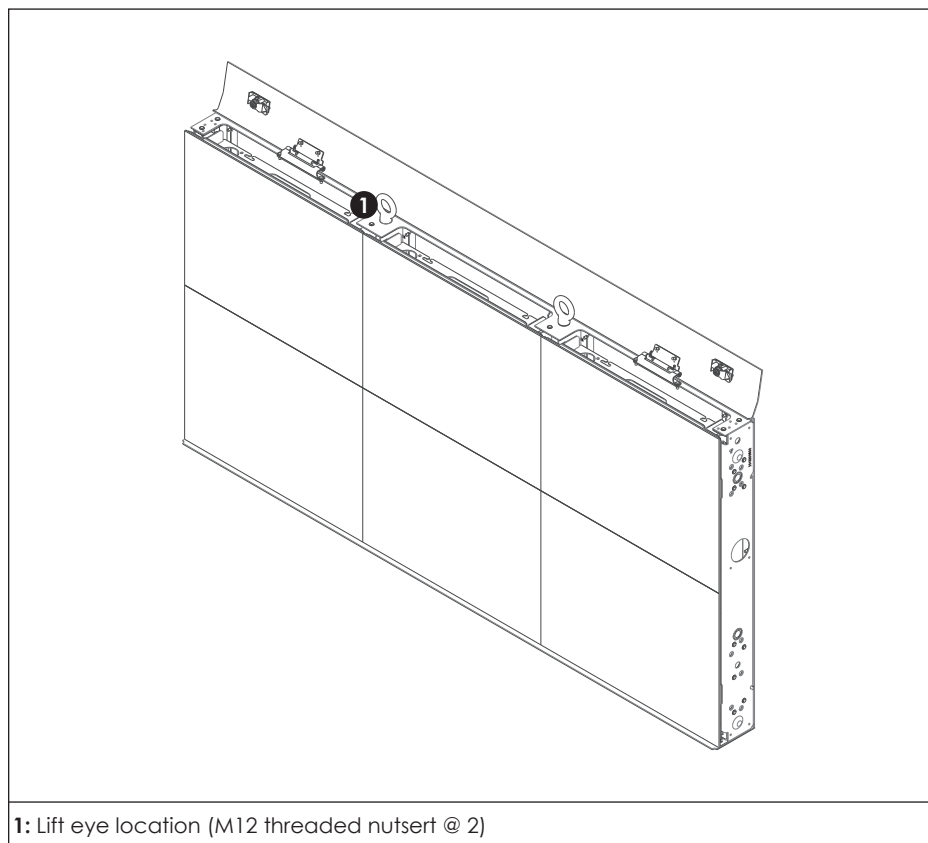

Figure 1: Display Front (Beverage Shroud Open)

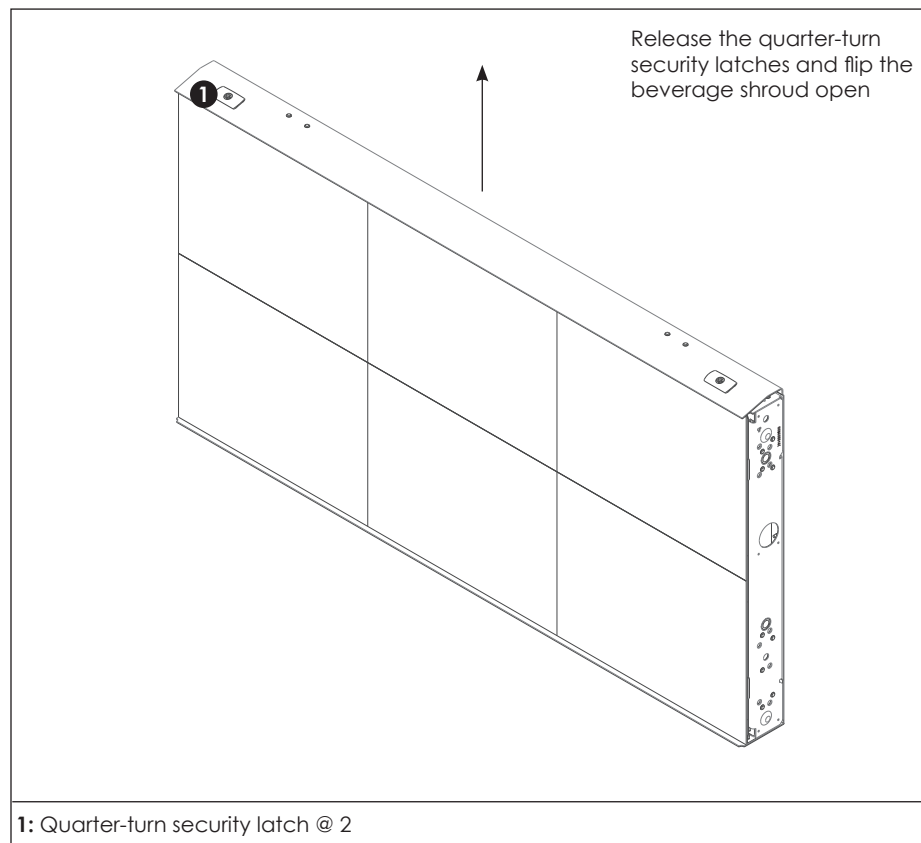

Figure 2: Beverage Shroud Removal

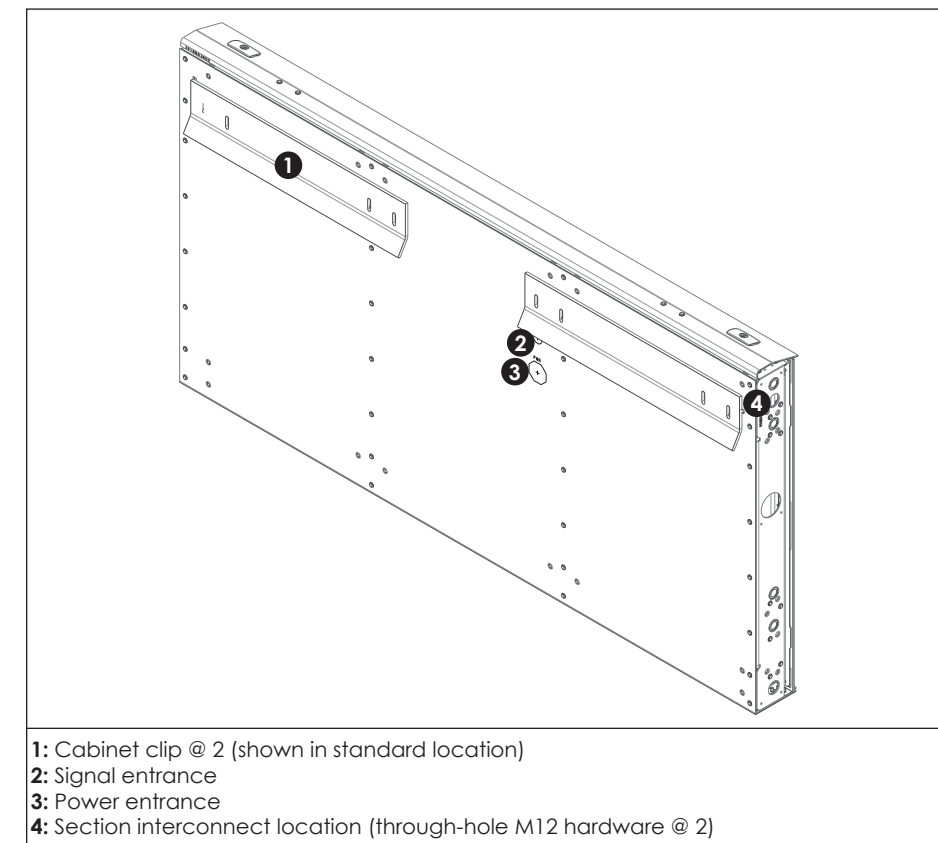

Figure 3: Display Rear

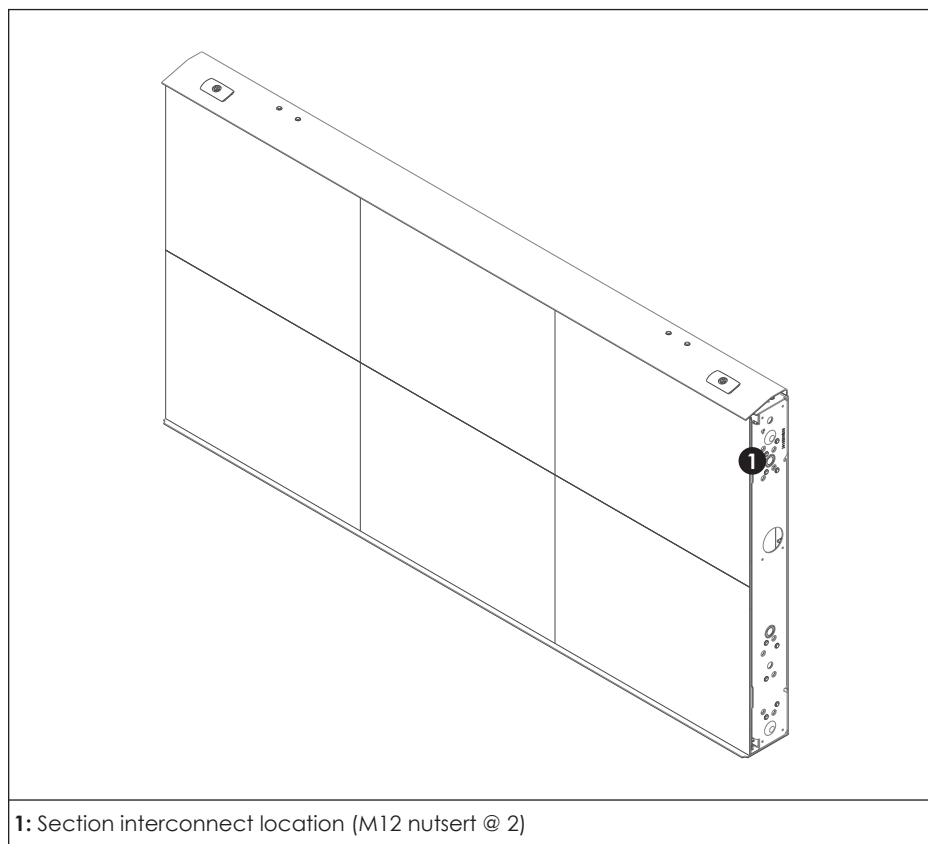

Figure 4: Display Front

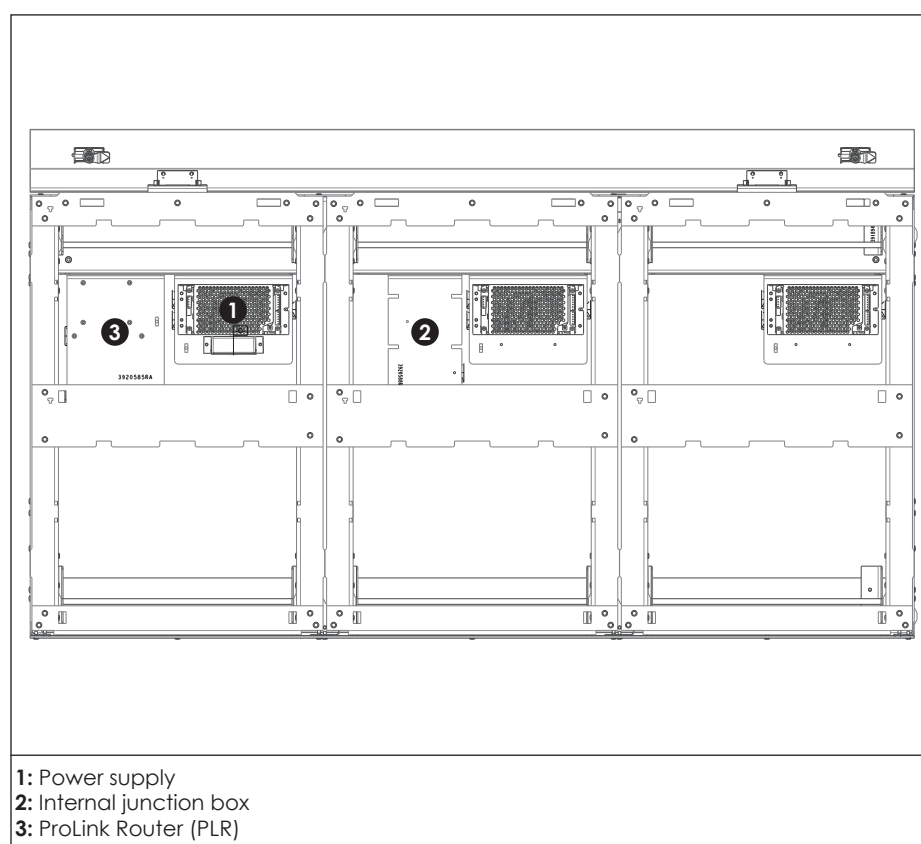
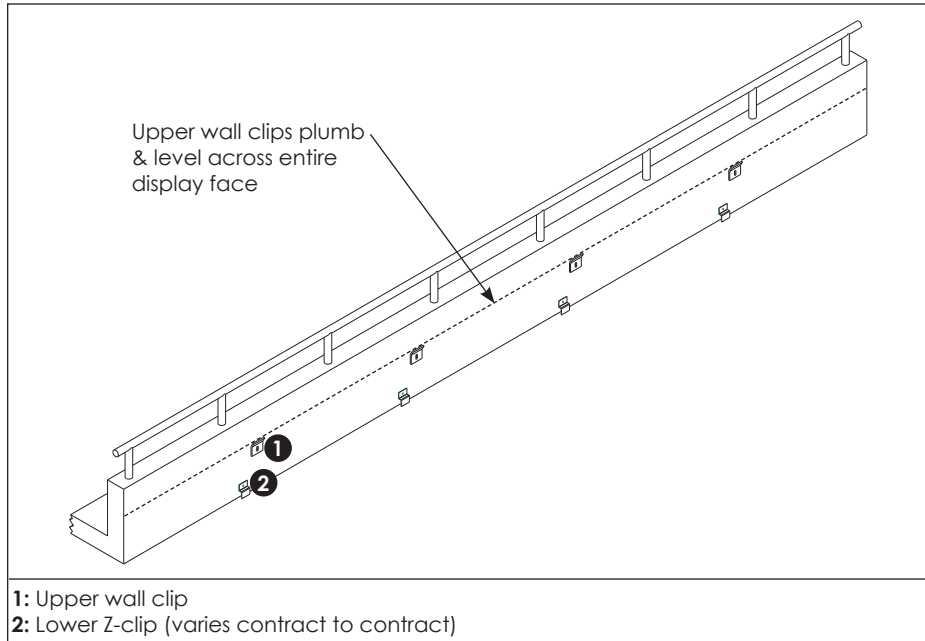

Figure 5: Component Locations (Front View with Module Column Removed)

## Mechanical

### Prepare Site

1. Level the upper wall clips. Refer to **Figure 1** and the contract-specific Shop Drawing for details. All upper wall clips must be plumb and level before hanging any sections.

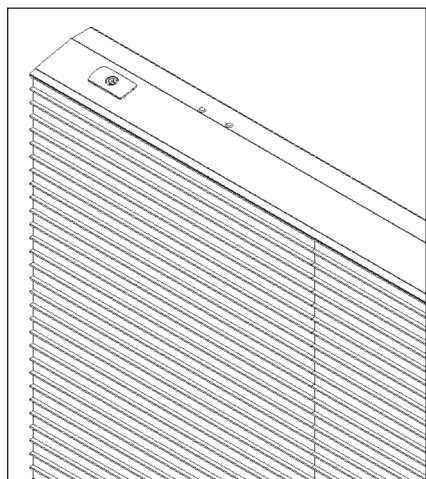

**Figure 1:** Plumb & Level Upper Wall Clips

2. Verify the lower Z-clips are installed per the contract-specific Shop Drawing. Refer to **Figure 1**.

### Install Standard Section

1. Rotate the beverage shroud latches counterclockwise with the  $\frac{5}{16}$ " hex security bit (Daktronics part number TH-1170) supplied in the toolkit to release the latches.
2. Rotate the beverage shroud upward to open the shroud. Refer to **Figure 3**.



**Figure 2:** Closed Beverage Shroud

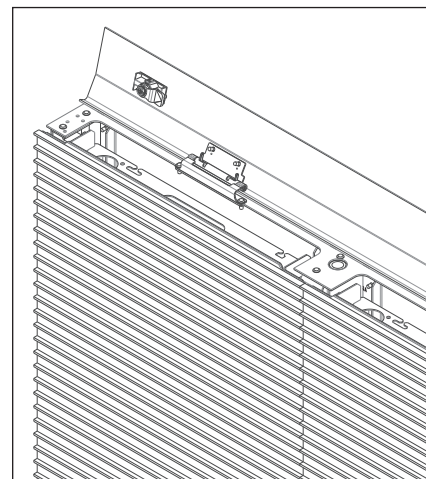
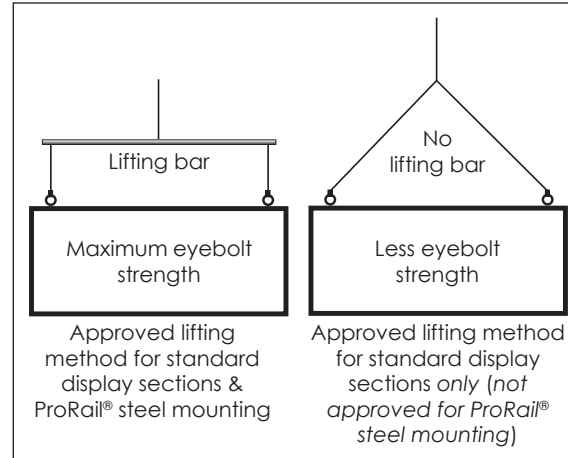

**Figure 3:** Open Beverage Shroud

3. Lift the display sections from the shipping crate using only the supplied lift eyes. A spreader beam is recommended when lifting but is required when ProRail® steel is attached. Refer to **Figure 4** and the **RTN-301 Series Section Crating Quick Guide (DD3963029)** for details. The sections may tip forward when lifting. Refer to **Figure 5**.

**Note:** Do not set sections on the ground.

The lift eyes must be installed into the display before attaching a hook.



**Figure 4:** Lift Display

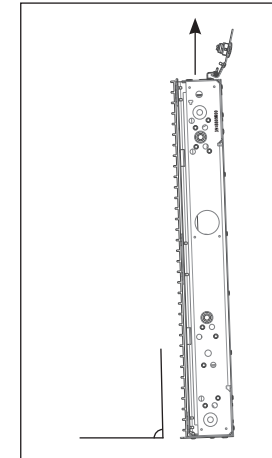

**Figure 5:** Lift Angle

4. Use the rear section clips to mount the display section to the wall. The display must mount directly to a non-combustible surface. Refer to **Figure 6** and **Figure 7**. Ensure the section sits completely in the upper wall clips.

**Note:** Clip placement varies by contract and may differ from what is shown in **Figure 6**.

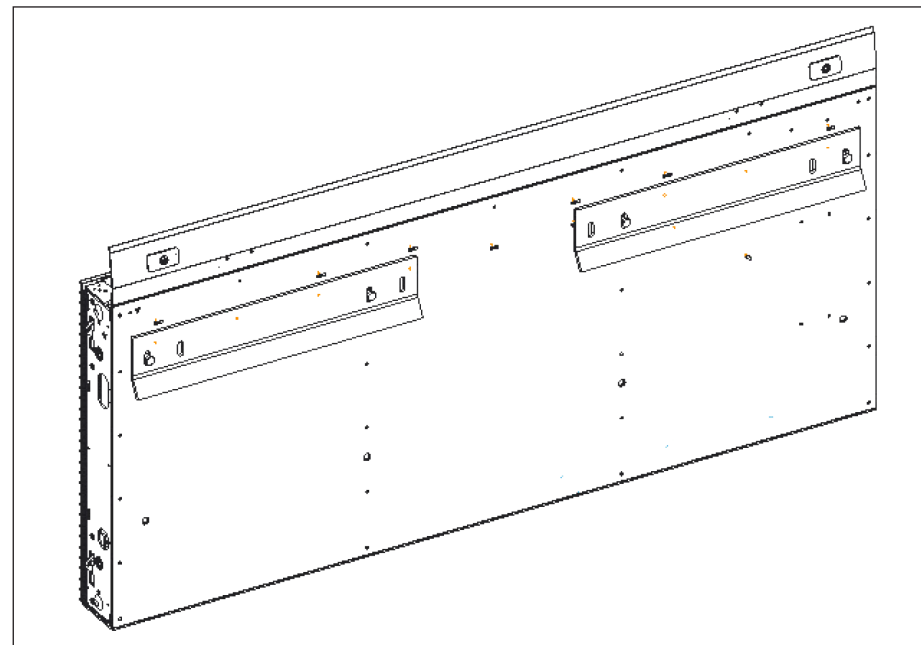

**Figure 6:** Rear Section Clips

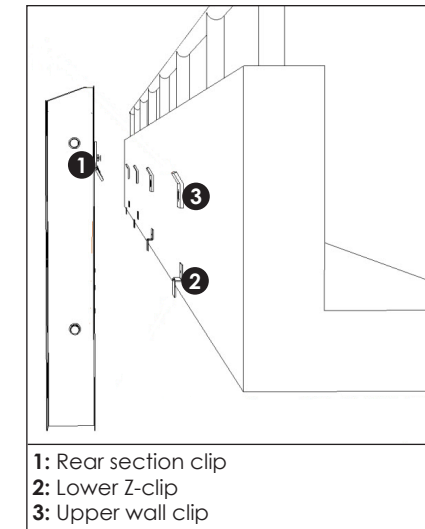

**Figure 7:** Mount Display to Wall

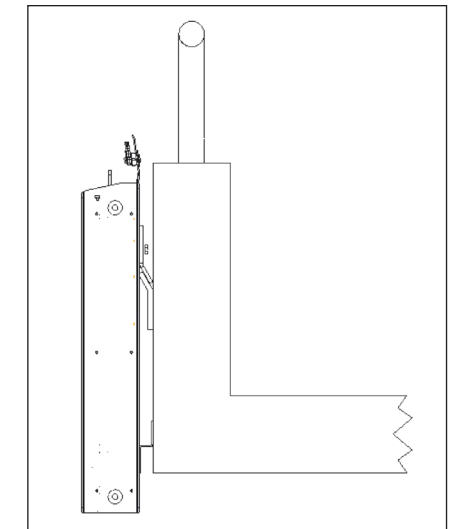
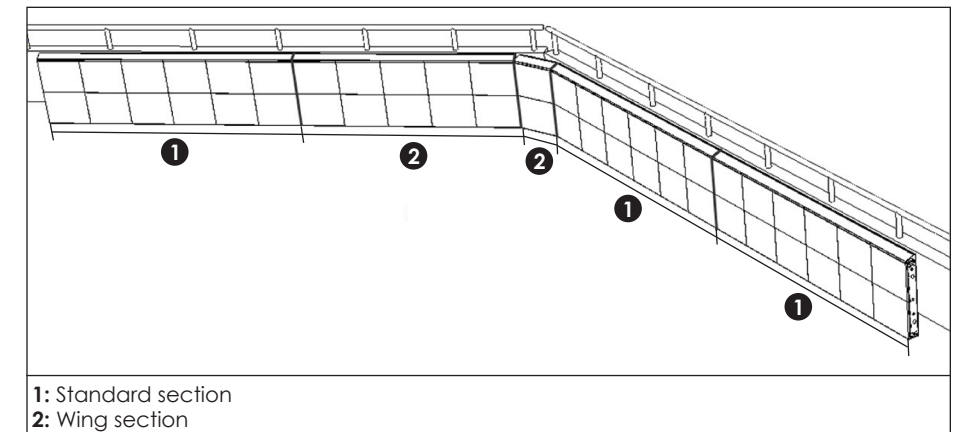

**Figure 8:** Display Attached to Wall

5. Ensure the section is plumb, level, and parallel to the wall. The alignment of the first section determines the alignment of the entire display. Refer to **Figure 8**.

**Note:** Remove the lift eyes from the top perimeter before closing the beverage shroud.

6. Repeat **Steps 1-5** to hang the next section. Ensure the sections are flush in all planes to the adjoining section. Follow the steps in **Install Wing Section (p.2)** to install a wing section. Refer to **Figure 9**.



**Figure 9:** Corner Transition

- Install two stitch bolts (HC-3829060) through the right perimeter into the adjacent cabinet. Remove the modules or the module pan entirely to access the stitch locations.

**Note:** Section-to-section seam tolerance should be  $\pm 5\%$  of the pixel pitch.  
Pixel pitch = 15 mm, Seam tolerance =  $\pm .75$  mm (.030")

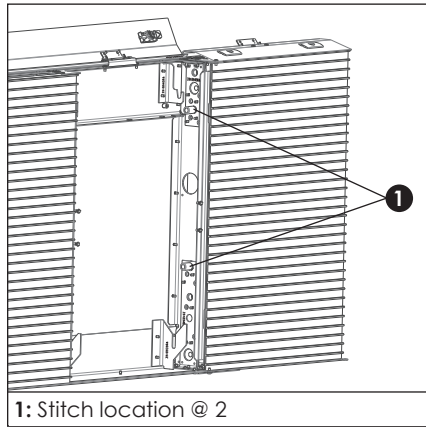

1: Stitch location @ 2

Figure 10: Interconnect Sections

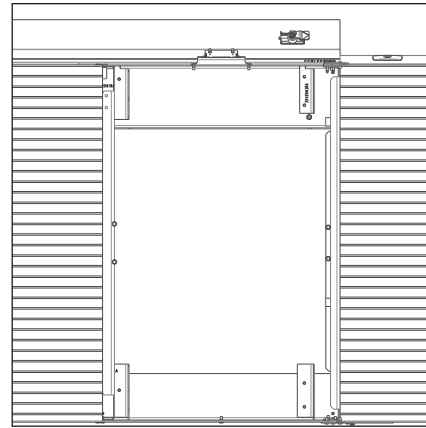

Figure 11: Interconnect Sections

- Attach the display to the lower Z-clips for uplift protection. The modules may need to be removed from the front to attach.

**Note:** This varies from contract to contract. Refer to the contract-specific Shop Drawing for further instructions.

- Close the beverage shroud and use the beverage shroud latches to secure the shroud.

## Install Borders

- Attach the borders with the supplied self-tapping screws (Daktronics part number HC-1778) if necessary. Refer to the contract-specific Shop Drawing for proper placement and to the **RTN-301 Series Border Installation Quick Guide (DD3956259)** for installation instructions.

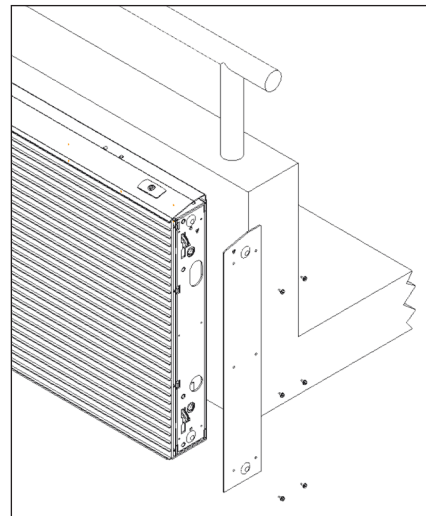
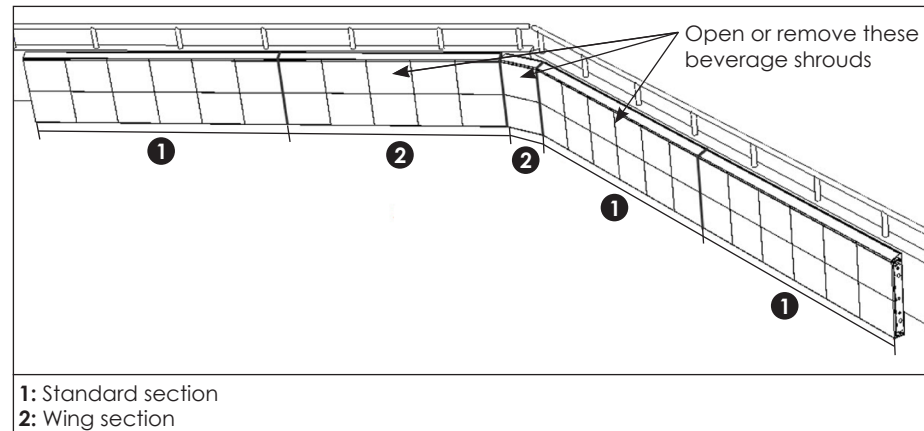

Figure 12: Typical Left & Right Border Attachment

## Install Wing Section

- Open the wing beverage shroud and adjacent sections' beverage shrouds. Refer to **Figure 13**.



1: Standard section  
2: Wing section

Figure 13: Open Wing Beverage Shroud

- Remove the retainer screws from the upper and lower support brackets and remove the stitch bolts holding the wing to the shell. Refer to **Figure 10**, **Figure 14**, and **Figure 15**. The wing section is now free to rotate. If the wing section does not rotate, ensure the side section stitch bolts to the left of the wing section are removed.

**Note:** These retainer screws will be reused in **Step 5** and **Step 6**.

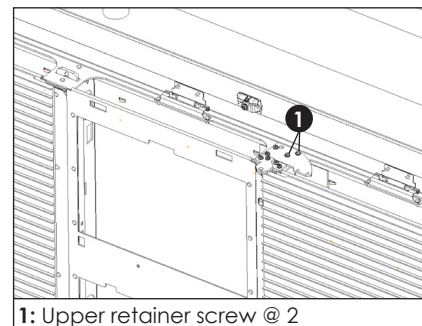

1: Upper retainer screw @ 2

Figure 14: Remove Upper Retainer Screws

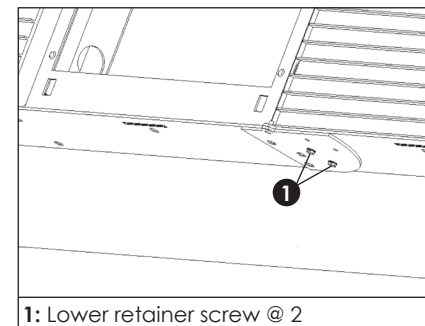

1: Lower retainer screw @ 2

Figure 15: Remove Lower Retainer Screws

- Set the wing at the necessary angle to engage the left and right sections. The hinge adds a gap (seam) between the module columns, which is necessary for top-access module removal via the module pan sliders. Refer to **Figure 16**.

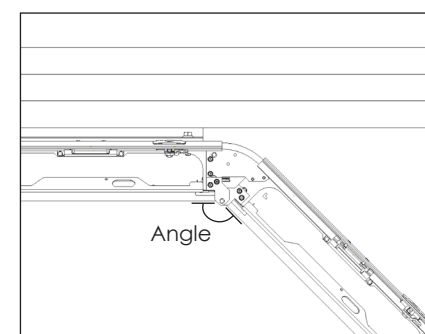
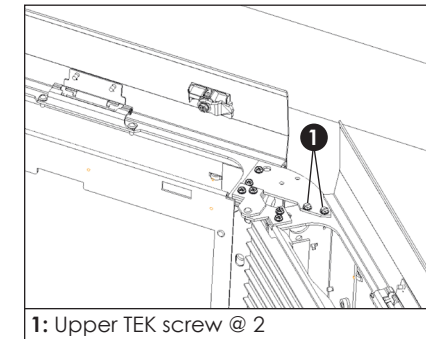

Figure 16: Set Wing at Necessary Angle

- Install TEK screws (Daktronics part number HC-1530) through the upper and lower support brackets into the left vertical of the wing to keep the wing from rotating. Refer to **Figure 17** and **Figure 18**.



1: Upper TEK screw @ 2

Figure 17: Install Upper TEK Screws

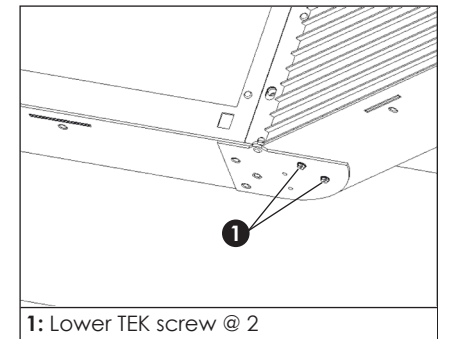

1: Lower TEK screw @ 2

Figure 18: Install Lower TEK Screws

- Install the upper support bracket and attach it to the top perimeters of the wing and the section to the right of the wing with #10 TEK screws (HC-1530). Refer to **Figure 19**.

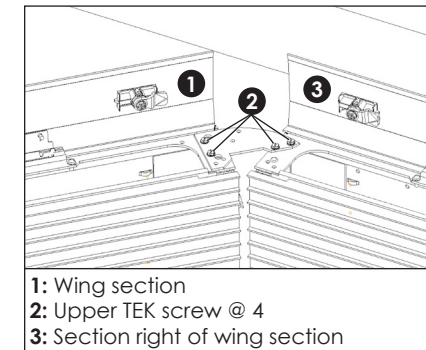

1: Wing section  
2: Upper TEK screw @ 4  
3: Section right of wing section

Figure 19: Install Upper Support Bracket

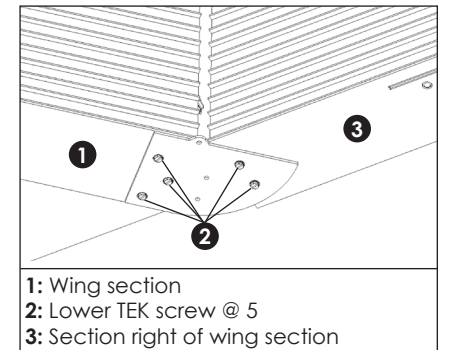

1: Wing section  
2: Lower TEK screw @ 5  
3: Section right of wing section

Figure 20: Install Lower Support Bracket

- Install the lower support bracket and attach it to the bottom caps of the wing and the section to the right of the wing with #10 TEK screws (HC-1530). Refer to **Figure 20**.
- Loosen and remove the upper hinge after all TEK screws are tightened down. The hinge needs to be removed to allow the beverage shrouds to close completely. Refer to **Figure 21** and **Figure 22**.

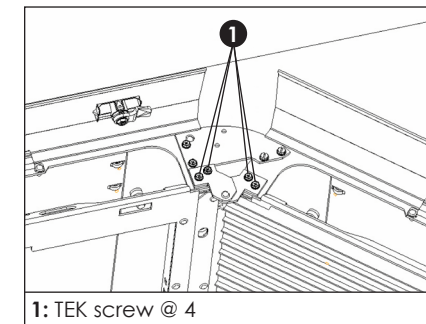

1: TEK screw @ 4

Figure 21: Remove Upper Hinge



Figure 22: Upper Hinge Removed

- Close and secure the beverage shrouds.

**Electrical**

**Power Termination**

Junction boxes ship separately from the display and are supplied for landing power. Refer to the contract-specific Riser Diagram for junction box locations within the display. Field power must be terminated in each junction box. The connections from the breaker panel to each junction box must be performed by a licensed electrician. Refer to **Figure 23**.

The junction box can power multiple sections on a three-phase 20 A circuit. Power is daisy-chained internally with factory-supplied harnessing. Refer to **DWG-3928063** for junction box field installation locations and field power connection details and to the Riser Diagram for field power locations within the display.

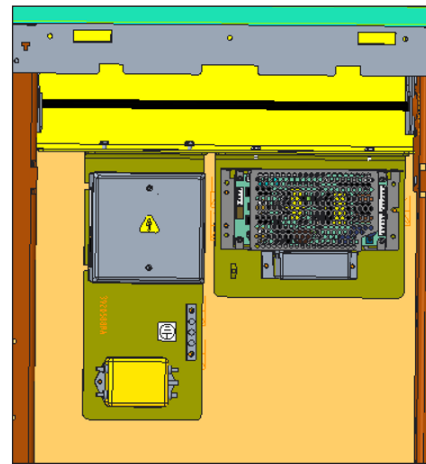

Figure 23: Power Entrance

**Signal Interconnection**

1. Use the supplied hardware to place the ProLink Router(s) (PLRs) at the locations specified on **DWG-3929866** and the contract-specific Signal Interconnect Drawing and Riser Diagram. Refer to **Figure 24**.

2. Route the field fiber cable (from the control location) through the signal entrance, then terminate. Refer to **Figure 25**.

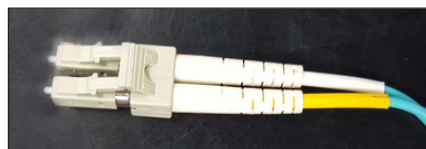

Figure 25: Fiber Cable

3. Use the supplied power cable (Daktronics part number W-3915142) to connect the PLR to the power supply fan connector. Refer to **Figure 26**.

4. Connect the field-terminated fiber cable to Fiber Port A on the first PLR in the system (typically the upper-right corner of the first cabinet when viewed from the rear). Refer to **Figure 26**.

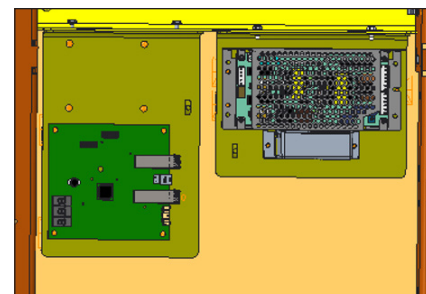

Figure 24: Mount PLR

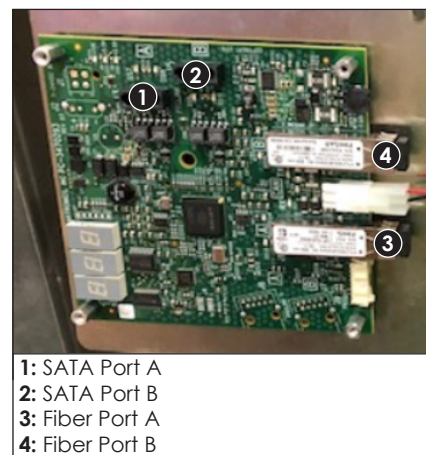

Figure 26: PLR

5. Route the supplied fiber cables from Fiber Port B on the first PLR to Fiber Port A on the next PLR. Refer to **Figure 26**. Depending on the number of PLRs, this process is continued until Fiber Port A on the final PLR in the chain is connected. Refer to the contract-specific Signal Interconnect Drawing.

6. Route the supplied SATA cable from SATA Port A on the PLR to SATA Port A on the first module. SATA connection between cabinets may be required depending on the overall display size. Use the supplied SATA cables to connect the cabinets. Refer to **Figure 27**. Cabinet-to-cabinet SATA connections are made via cables secured to the top of each module column. Refer to the Signal Interconnect Drawing for data routing information.



Figure 27: SATA Cable

**Service**

**Module**

**Front-Access**

1. Disconnect power to the display.
2. Turn the top spring latch a 3/4 turn counterclockwise with a small flathead screwdriver. Refer to **Figure 28**.
3. Rotate the top of the module outward and lift up. Pull the module from the display just far enough to reach around to the back of the unit and attach one end of a module safety lanyard to the rings on the module and the other end to a secure location within the display to prevent the module from falling if dropped.

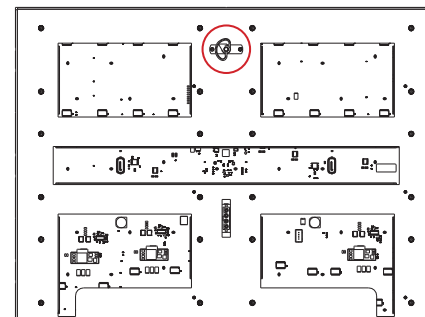

Figure 28: Module Rear

**Note:** Do not allow the module to hang by the power or SATA cables, as this may damage the module or cabling.

4. Disconnect the power and signal cables from the rear of the module.

Reverse these steps to install a module in a front-access display.

**Top-Access**

1. Disconnect power to the display.
2. Remove the module pan. Refer to **Module Pan (p.3)** for instructions.
3. Turn the top spring latch a 3/4 turn counterclockwise with a small flathead screwdriver.

4. Rotate the top of the module outward and lift up.
  5. Disconnect the power and signal cables from the rear of the module.
- Reverse these steps to install a module in a top-access display.

**Module Pan**

Pay special attention to the following instructions to avoid damaging any connectors or components.

1. Disconnect power to the display.
2. Release the beverage shroud security latches with a 5/16" hex security bit (Daktronics part number TH-1170). Leave the beverage shroud in a flipped-up position or remove it by rotating it up and unhooking the spring-loaded hinge pins. Refer to **Figure 29** and **Figure 30**.

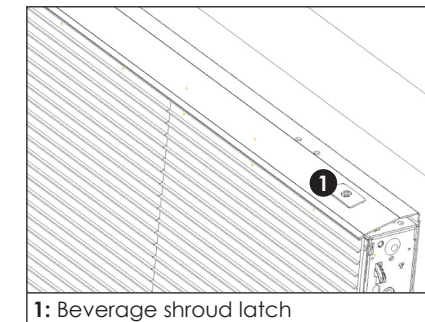

Figure 29: Remove Beverage Shroud

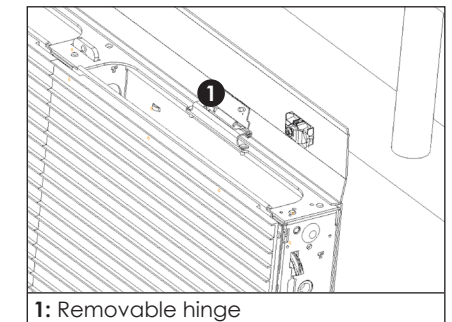

Figure 30: Remove Beverage Shroud

3. Disconnect the power and signal cables for the column to be removed.

4. Attach one end of a safety lanyard to the labeled attachment point on the top of the column and the opposite end of the lanyard to the labeled attachment point on the adjacent column to prevent the column from falling if dropped. Refer to **Figure 31**.



Figure 31: Attach Safety Lanyard

5. Maintain a firm grip on the column and pull away from the display to disengage the column from the attachment points. The column can be moved to an area for servicing.

Reverse these steps to install a module pan in a top-access display.

## ProLink Router

### Front-Access

1. Disconnect power to the display.
2. Remove the module directly in front of the ProLink Router (PLR). Refer to the **RTN-301 Series Section Basics Quick Guide (DD3956753)** for location details and to **Module (p.3)** for removal instructions.
3. Unplug SATA Port A and SATA Port B, the fiber transmit and receive dual LC connections, and the two-pin power jack from the PLR. Refer to **Figure 26**.
4. Pull the PLR mounting plate from the display. Refer to **Figure 24**.
5. Remove the screws attaching the PLR to the mounting plate with a Phillips screwdriver and replace the OP board or remove the screw with a  $\frac{5}{16}$ " nutdriver and replace the OA assembly.

Reverse these steps to install a PLR in a front-access display.

### Top-Access

1. Disconnect power to the display.
2. Remove the module pan. Refer to **Module Pan (p.3)** for instructions.
3. Unplug SATA Port A and SATA Port B, the fiber transmit and receive dual LC connections, and the two-pin power jack from the PLR. Refer to **Figure 26**.
4. Pull the PLR mounting plate from the display. Refer to **Figure 24**.
5. Remove the screws attaching the PLR to the mounting plate with a Phillips screwdriver and replace the OP board or remove the screw with a  $\frac{5}{16}$ " nutdriver and replace the OA assembly.

Reverse these steps to install a PLR in a top-access display.

## Component Locations

Refer to the **RTN-301 Series Section Basics Quick Guide (DD3956753)** for component locations.

## Tools

Part	Part Description
5/16" Nutdriver or bit (Daktronics part number TH-1156) or 8 mm nutdriver or bit	Attaches borders
Cordless screw gun	Attaches borders to sections
Crane or lift	Lifts sections from crates and holds sections for border attachment

## Part Identification

There are three flat side border sizes for the RTN-301 display series:

- 1T-1S (1 tall-1 short) section height (Daktronics part number 0M-3921958)
- 1T-2S (1 tall-2 short) section height (0M-3921969)
- 2T/3S (2 tall or 3 short) section height (0M-3921967)

Refer to **Figure 1**.

There are three transition border sizes for the RTN-301 display series:

- 1T-1S (1 tall-1 short) section height (0M-3923759)
- 1T-2S (1 tall-2 short) section height (0M-3923763)
- 2T/3S (2 tall or 3 short) section height (0M-3923761)

Refer to **Figure 2**.

Part numbers are etched into the metal on each border for identification purposes.

## Border Installation

Flat side borders can be installed before or after display sections are mounted to the structure. Transition borders must be installed prior to installing any adjacent display sections.

1. Select the correct border size to match the display section size.
2. Use a clean rag to wipe off the perimeter of the cabinet receiving the border.

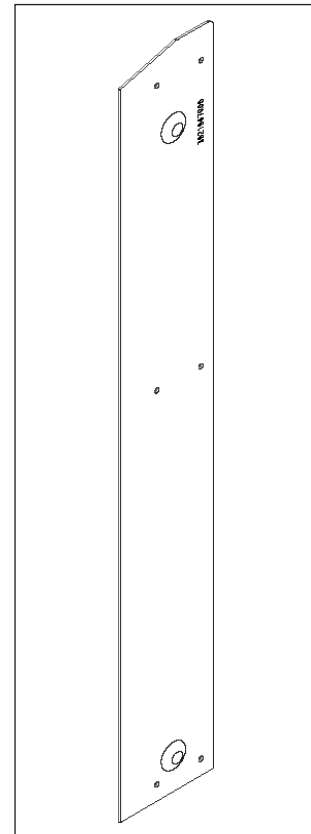

Figure 1: Flat Side Border

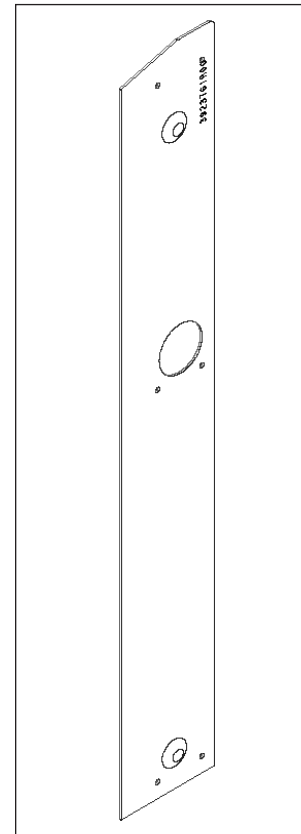

Figure 2: Transition Border

3. Bring the border into position. The formed offset feature should be positioned to fit over the protruding alignment cone. Refer to **Figure 3**.

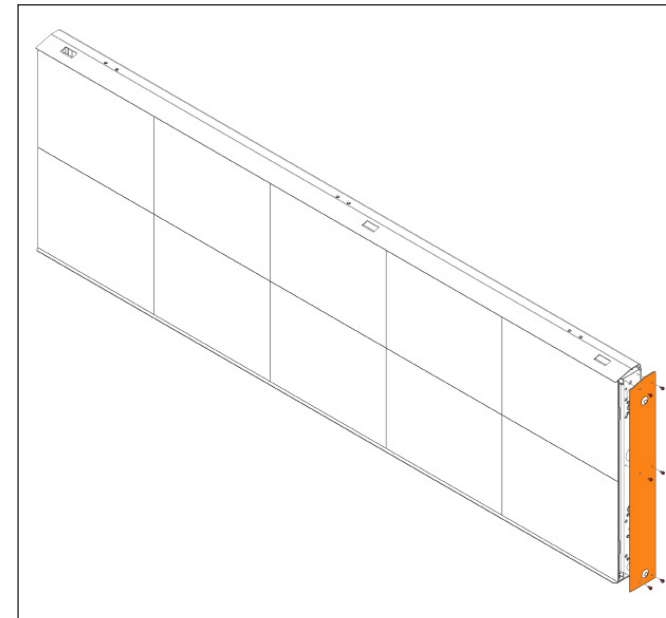

Figure 3: Install Border

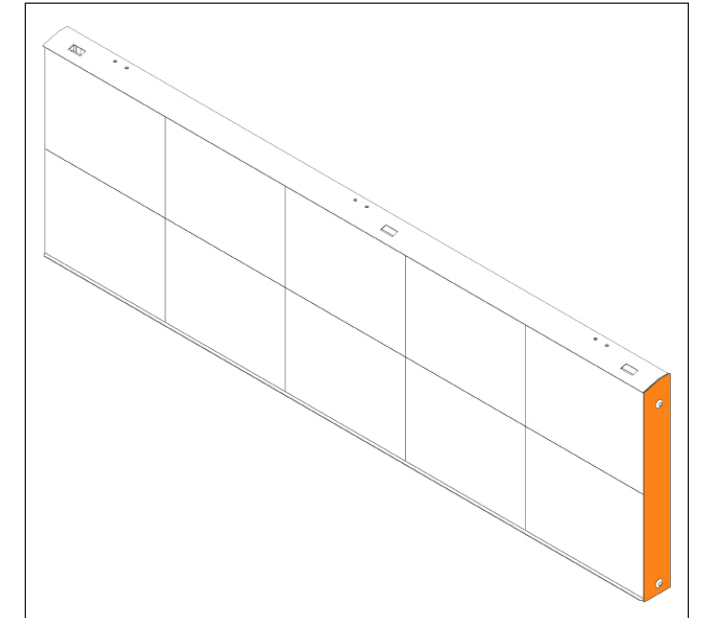

Figure 4: Border Installed

4. Ensure the pre-punched holes in the border align with the pilot holes in the section perimeter. With the holes aligned, use #10-16 x 0.375" tap screws (Daktronics part number HC-1186) to fasten the border to the section perimeter in all pre-punched hole locations in the border. Refer to **Figure 4** for the finished appearance.

*This page intentionally left blank.*

# B Reference Drawings

Refer to **Numbering Conventions (p.1)** for information regarding how to read the drawing number. These drawings offer general information pertaining to most RTN-301 series displays and are listed in numeric order. Any contract-specific drawings take precedence over the general drawings.

Block Diagram; 2 Mod/Pan High, RTN-301 .....	<b>DWG-3916609</b>
Block Diagram; 3 Mod/Pan High, RTN-301 .....	<b>DWG-3916610</b>
Assy; 2 Gang J-Box RTN B1 .....	<b>DWG-3928063</b>
Component Placement; RTN B1 .....	<b>DWG-3929851</b>
Assy; PLR 6054 & Fiber Converter, w/Mtg, RTN B1 .....	<b>DWG-3929854</b>
Assy; PLR 6054 w/Mtg, RTN B1 .....	<b>DWG-3929866</b>
RTN-301 Field Wiring Guide .....	<b>DWG-5169344</b>

# SIGNAL

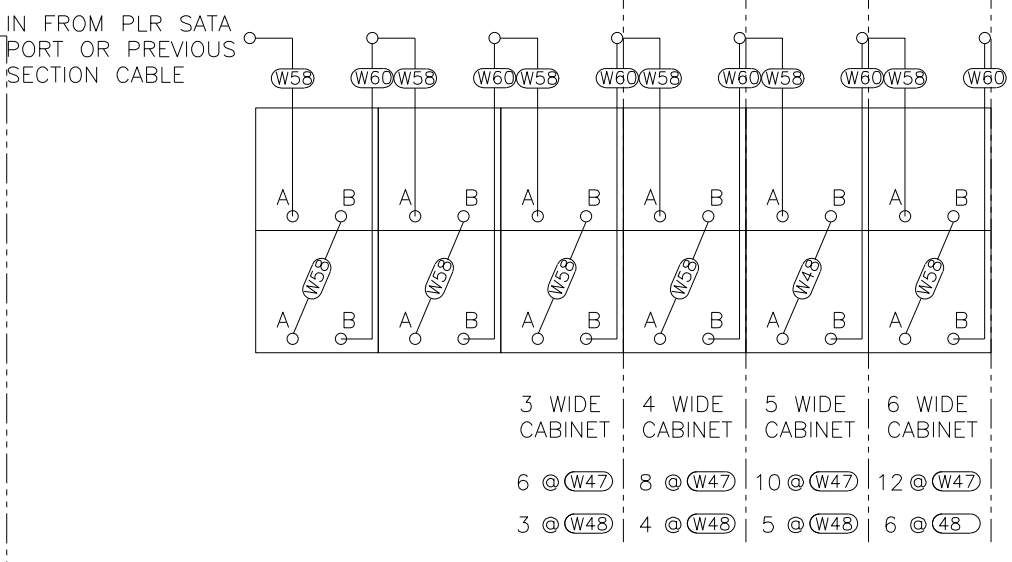
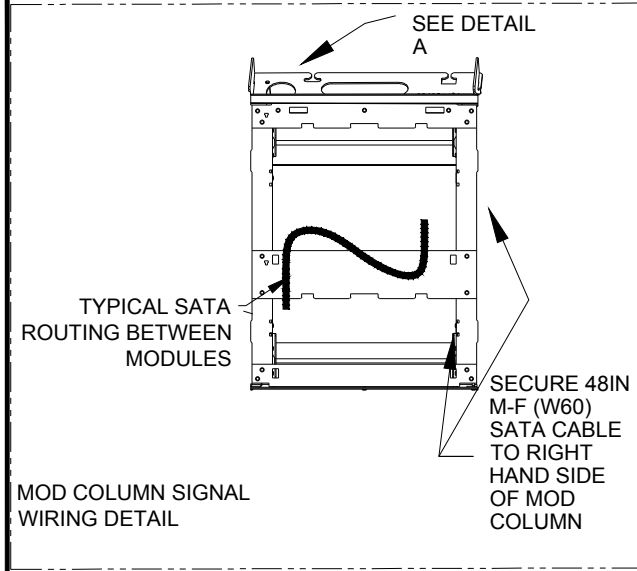

TO TOP MOD IN NEXT SECTION OR PLR (BASED ON INTERCONNECT DWG)

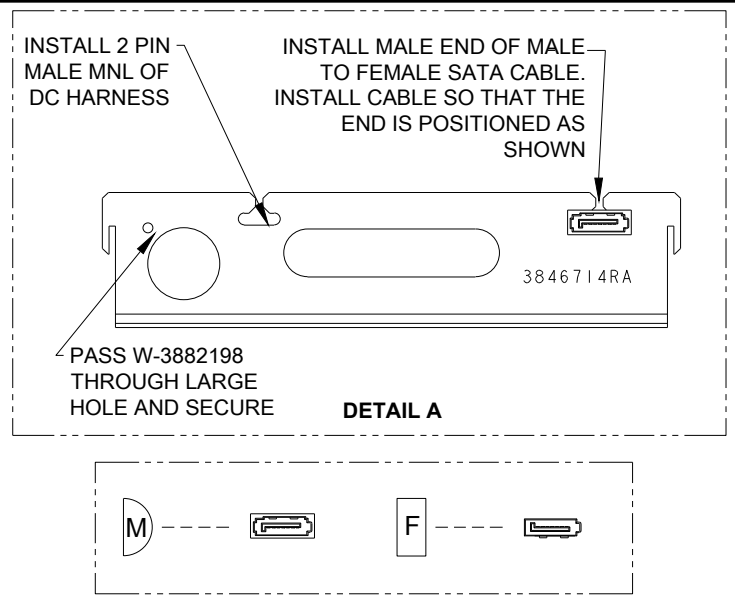

- (W58) W-3882198  
SATA ASSY; 7P RA F-7P RA F, 28IN, XOVER
- (W60) W-3882201  
SATA ASSY; 7P RA F-7P M, 48IN, STR8

# POWER

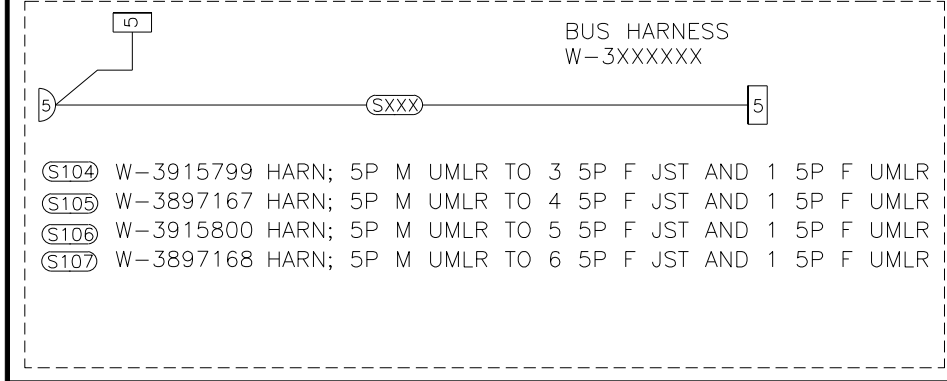
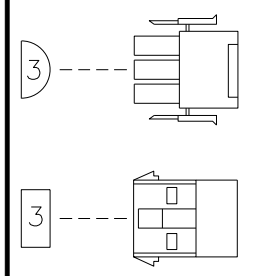
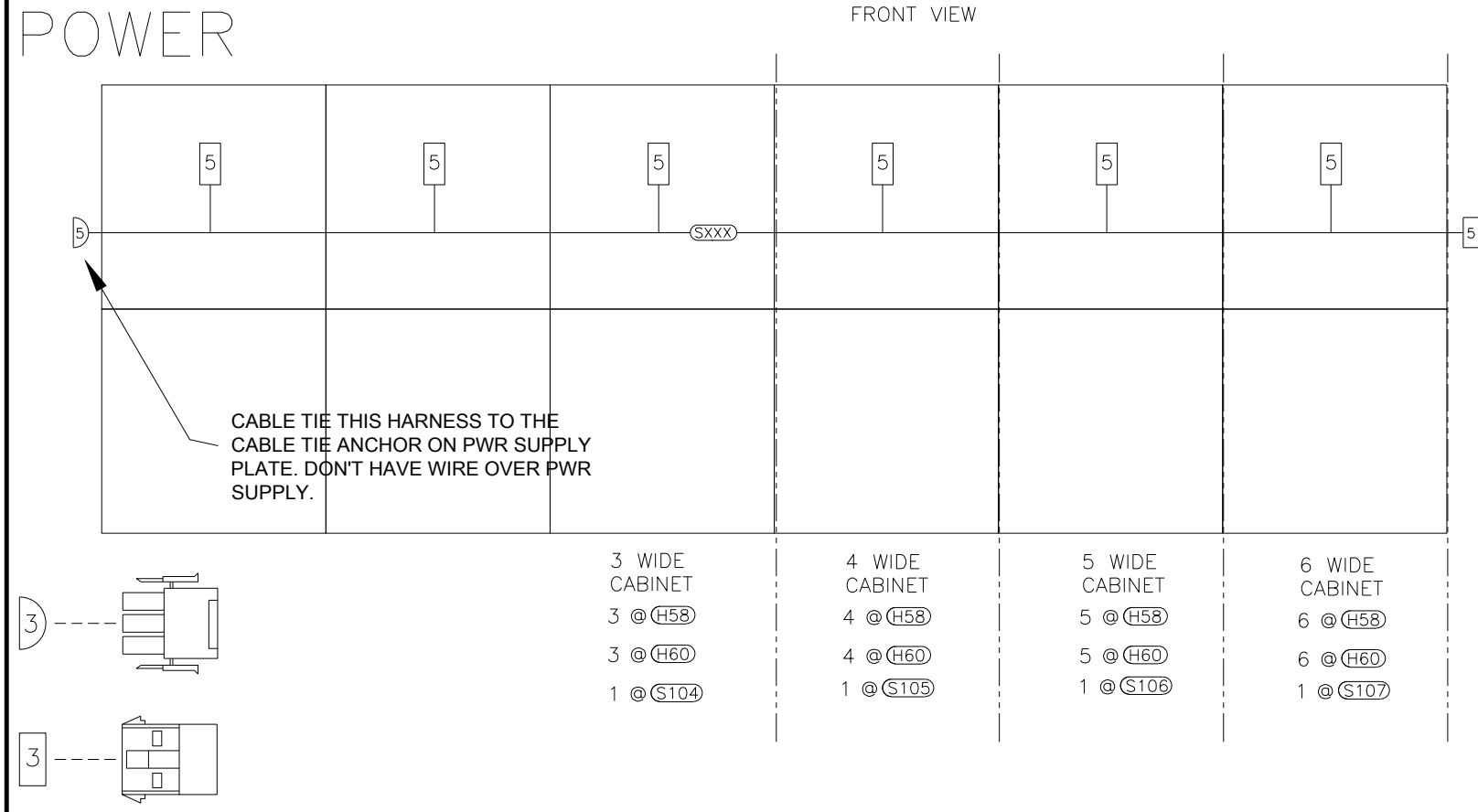

- (S104) W-3915799 HARN; 5P M UMLR TO 3 5P F JST AND 1 5P F UMLR
- (S105) W-3897167 HARN; 5P M UMLR TO 4 5P F JST AND 1 5P F UMLR
- (S106) W-3915800 HARN; 5P M UMLR TO 5 5P F JST AND 1 5P F UMLR
- (S107) W-3897168 HARN; 5P M UMLR TO 6 5P F JST AND 1 5P F UMLR

# SECONDARY

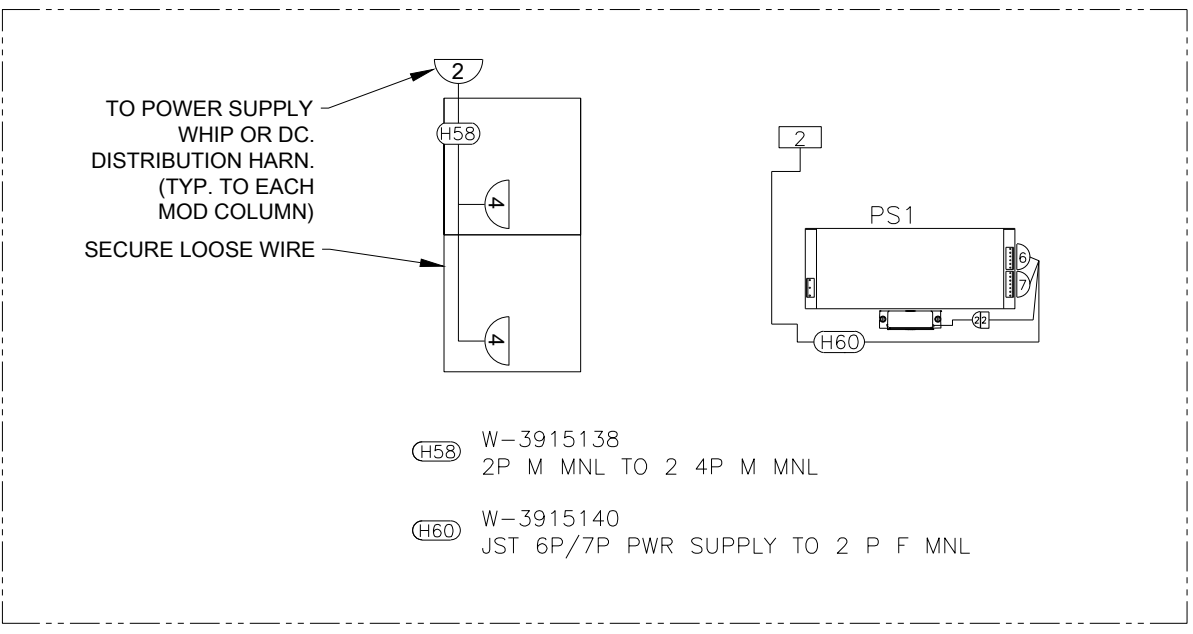

- (H58) W-3915138  
2P M MNL TO 2 4P M MNL
- (H60) W-3915140  
JST 6P/7P PWR SUPPLY TO 2 P F MNL

REV 01	DATE: 16 JUL 18	CN59588 UPDATE GENDER SYMBOL FOR BUS HARNESS, ADDED SATA CABLE ORIENTATION	BY: JSF
PROJECT: RTN B1		TITLE: BLOCK DIAGRAM; 2 MOD/PAN HIGH, RTN-301	
DATE: 24 MAY 18	DIM UNITS: INCHES [MILLIMETERS]	SHEET	REV 01
SCALE: NTS	DO NOT SCALE DRAWING		
DESIGN: JFIXSEN	JOB NO. P2094	FUNC - TYPE - SIZE F - 01 - B	3916609
DRAWN: JFIXSEN			

THE CONCEPTS EXPRESSED AND DETAILS SHOWN ON THIS DRAWING ARE CONFIDENTIAL AND PROPRIETARY. DO NOT REPRODUCE BY ANY MEANS WITHOUT THE EXPRESS WRITTEN CONSENT OF DAKTRONICS, INC. OR ITS WHOLLY OWNED SUBSIDIARIES. COPYRIGHT 2018 DAKTRONICS, INC. (USA)

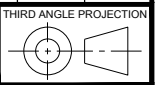

# SIGNAL

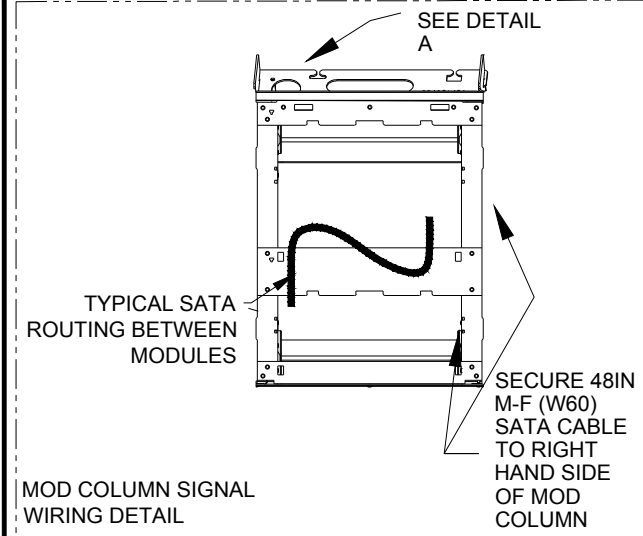

IN FROM PLR SATA PORT OR PREVIOUS SECTION CABLE

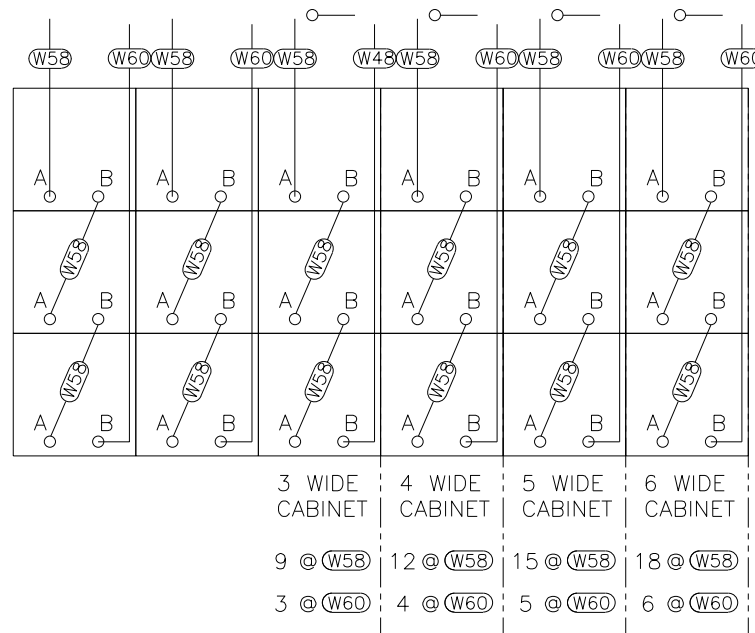

- (W58) W-3882198 SATA ASSY; 7P RA F-7P RA F, 28IN, XOVER
- (W60) W-3882201 SATA ASSY; 7P RA F-7P M, 48IN, STR8

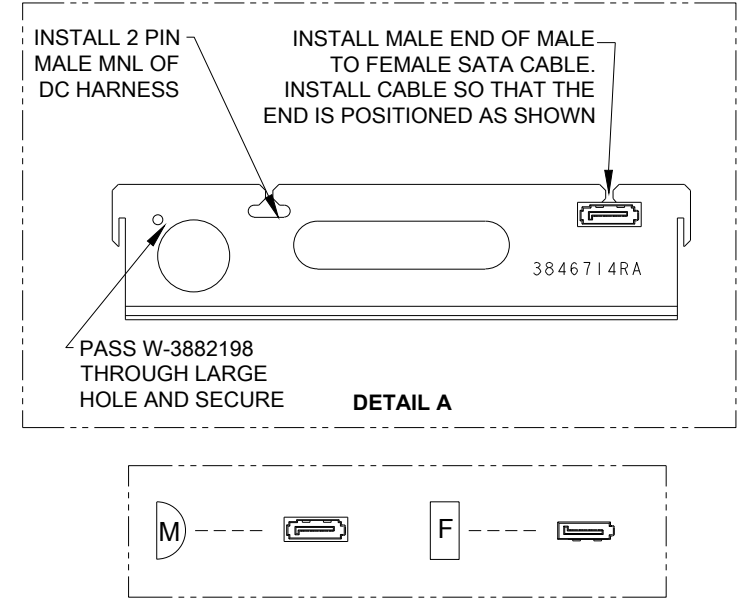

# POWER

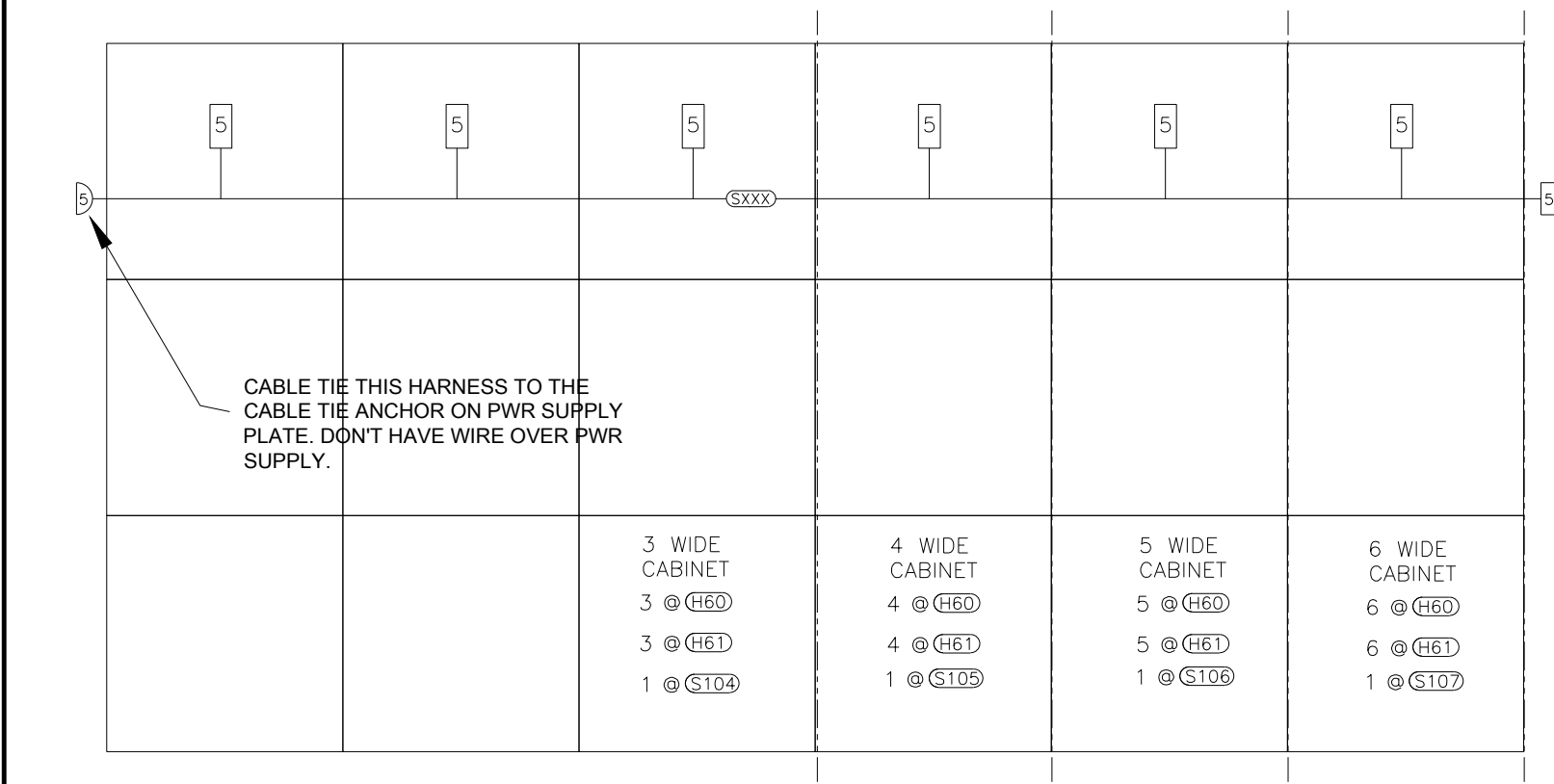

# SECONDARY

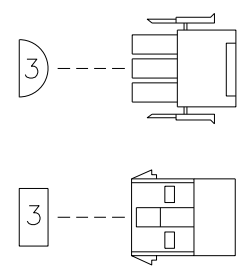
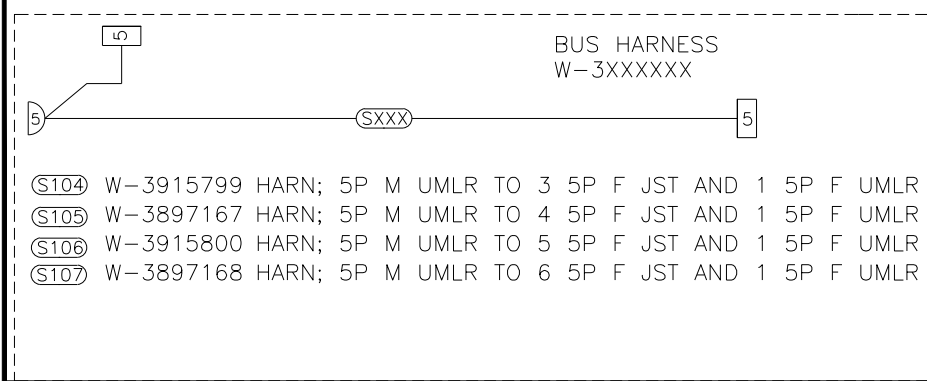
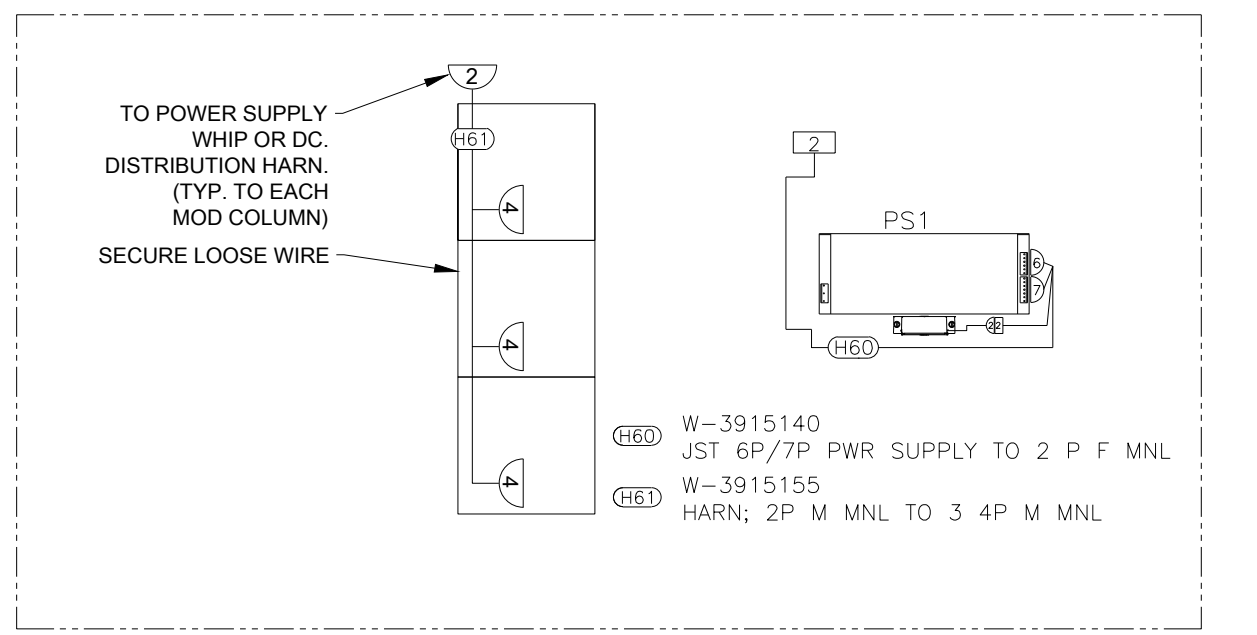

REV 01	DATE: 16 JUL 18	CN59588 UPDATE GENDER SYMBOL FOR BUS HARNESS, ADDED SATA CABLE ORIENTATION	BY: JSF
<p>THE CONCEPTS EXPRESSED AND DETAILS SHOWN ON THIS DRAWING ARE CONFIDENTIAL AND PROPRIETARY. DO NOT REPRODUCE BY ANY MEANS WITHOUT THE EXPRESS WRITTEN CONSENT OF DAKTRONICS, INC. OR ITS WHOLLY OWNED SUBSIDIARIES. COPYRIGHT 2018 DAKTRONICS, INC. (USA)</p>			
PROJECT: RTN			
TITLE: BLOCK DIAGRAM; 3 MOD/PAN HIGH, RTN-301			
DATE: 14 MAY 18	DIM UNITS: INCHES [MILLIMETERS]	SHEET	REV 01
SCALE: NTS	DO NOT SCALE DRAWING		
DESIGN: JFIXSEN	JOB NO. P2094	FUNC - TYPE - SIZE F-01-B	3916610
DRAWN: JFIXSEN			

0A-1487-6855			
INDEX	NAME	QTY	DESCRIPTION
1	0M-3850703	1	INTERIOR PLATE, INTERNAL JBOX 3/4 POS
2	0S-3920590	1	J-BOX PLATE ASM; RTN-301, B1
3	EC-3785856	1	JUNCTION BOX; 2G WP BOX W/ 3-3/4" HUBS, 2"DEEP
4	EC-3785862	1	JUNCTION BOX COVER, 2 GANG, BLANK W/GASKET
5	HC-1141	1	MACH SCR, #6-32 X 1.000, PHIL PAN HEAD, ZN PLTD
6	HC-1186	2	TAP SCR, #10-16 X 0.375, PHIL HEX WSHR HEAD
7	HC-1238	4	NUT, #6-32 HEX KEPS, ZN PLTD
8	LL-2285	1	LABEL, 2 X 1 BLANK WHT FOR ZEBRA PRINTER
9	LL-2305	1	LABEL, SERIAL NO./SPECS, 1 WINDOW, PER DWG 92514
10	LL-2602	1	LABEL, ELECTRIC SHOCK HAZARD, YELLOW W/ BLACK TEXT
11	LL-2812	1	LABEL, GROUND SYMBOL DECAL SHEET, PER DWG-1041433
12	LL-3922635	2	ll-3922635.prt
13	TB-1203	1	GROUND BAR, WS #6TO14, SLOTTED SET SCREW,3POS,WET
14	TB-3785819	1	TERMINAL, 4 POLE, 15MM SPACING, 50A 600V, 18-8AWG
15	Z-1010	1	INACTIVE; 13-20 AMP LOWER CURRENT THREE PHASE RFI

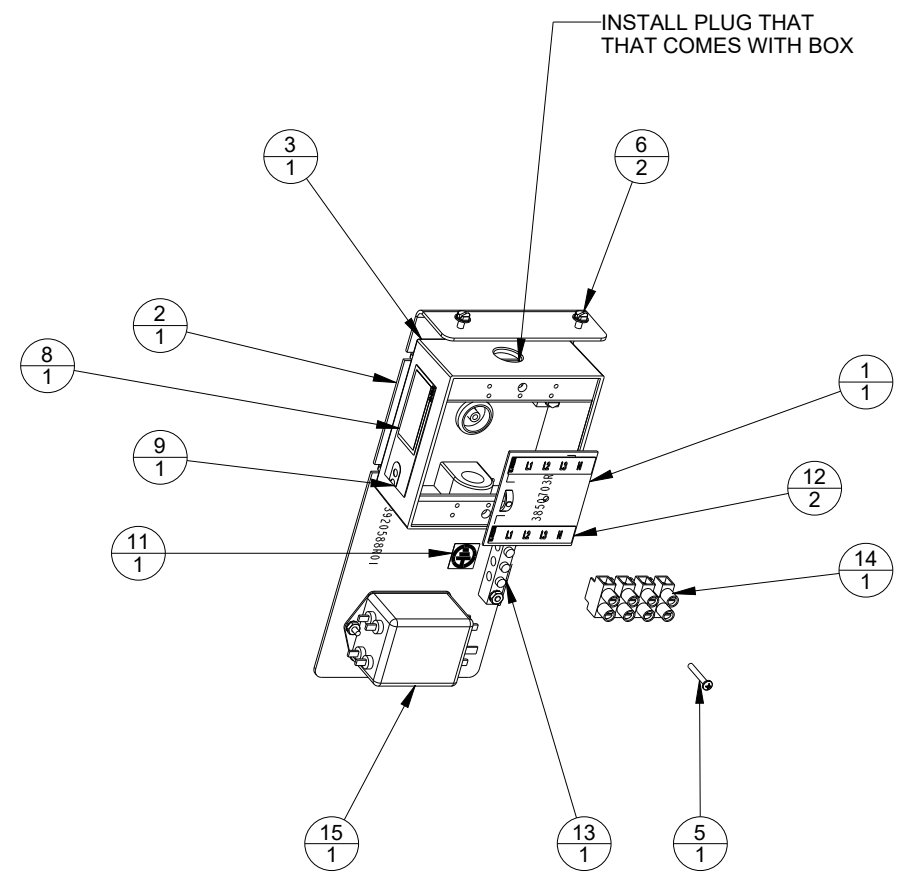
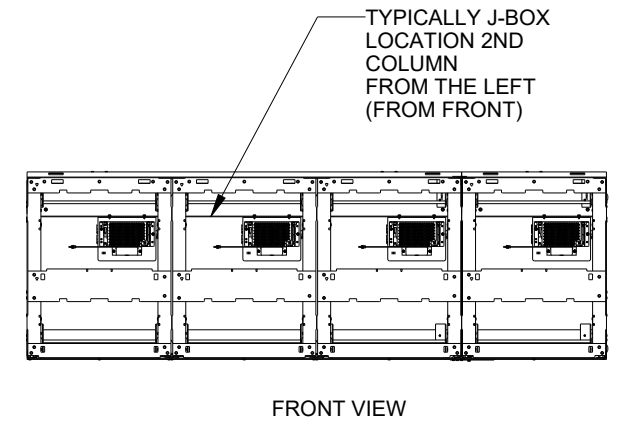

TB-3785819	10 IN-LBS
HC-1141	10 IN-LBS
HC-1238	10 IN-LBS
HC-3601959	10 IN-LBS
HC-3612828	25 IN-LBS
EC-3785862 COVER SCREWS	3 IN-LBS
TOP PLUG FOR JBOX	10 IN-LBS
TB-1203	25 IN-LBS

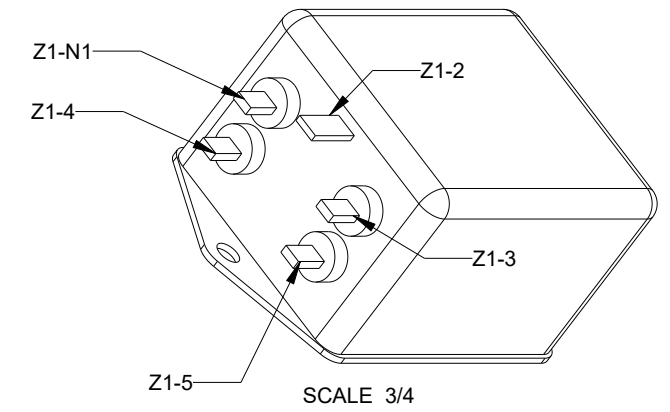
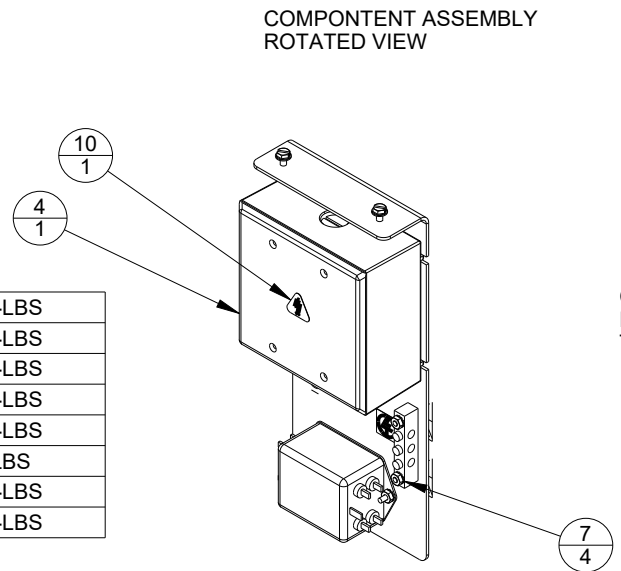

CONNECT HARNESS (NOT SHOWN) ON TO THE FILTER AND ON TO THE TERMINAL BLOCK PER THE PINOUT LABELED ON THE HARNESS.

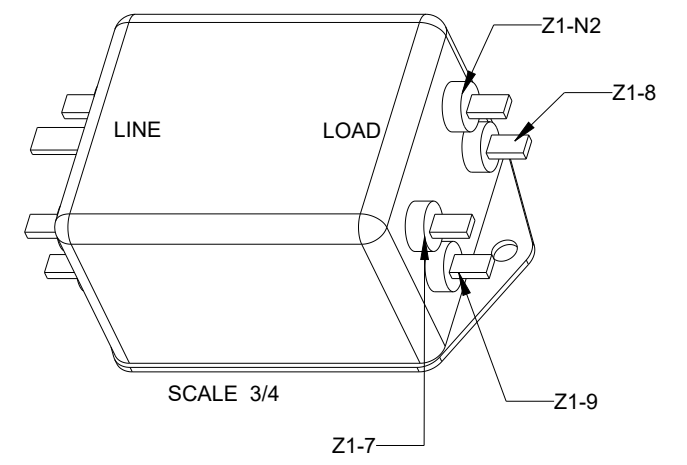

REV: 02	DATE: 17NOV20	PER CN-111990: UPDATED BOM TABLE TO SHOW HC-1238 @4	BY: LJH 07198
			THIRD ANGLE PROJECTION
PROJECT: RTN-B1			
TITLE: ASSY; 2 GANG J-BOX RTN B1			
DATE: 17-NOV-20	DIM UNITS: INCHES [MILLIMETERS]	SHEET	REV 02
SCALE: 1/5 DO NOT SCALE DRAWING			
DESIGN: JFIXSEN	JOB NO. C1234	FUNC - TYPE - SIZE E - 07 - B	3928063
DRAWN: JFIXSEN			

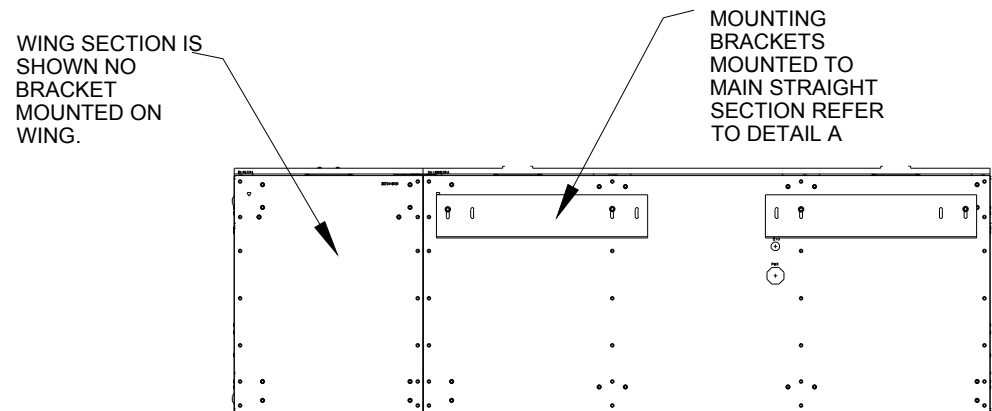

REAR VIEW

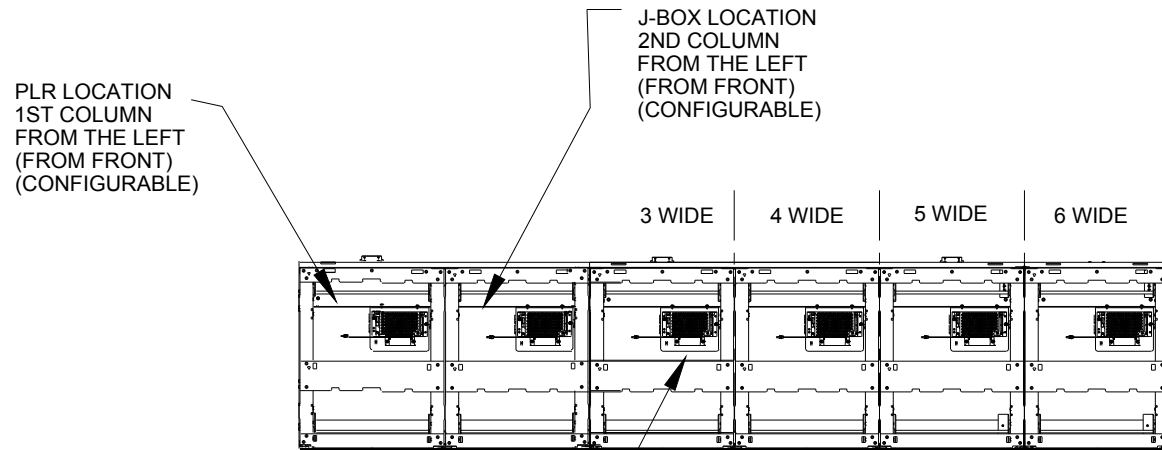
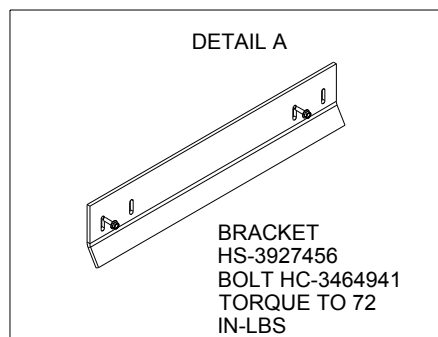

FRONT VIEW

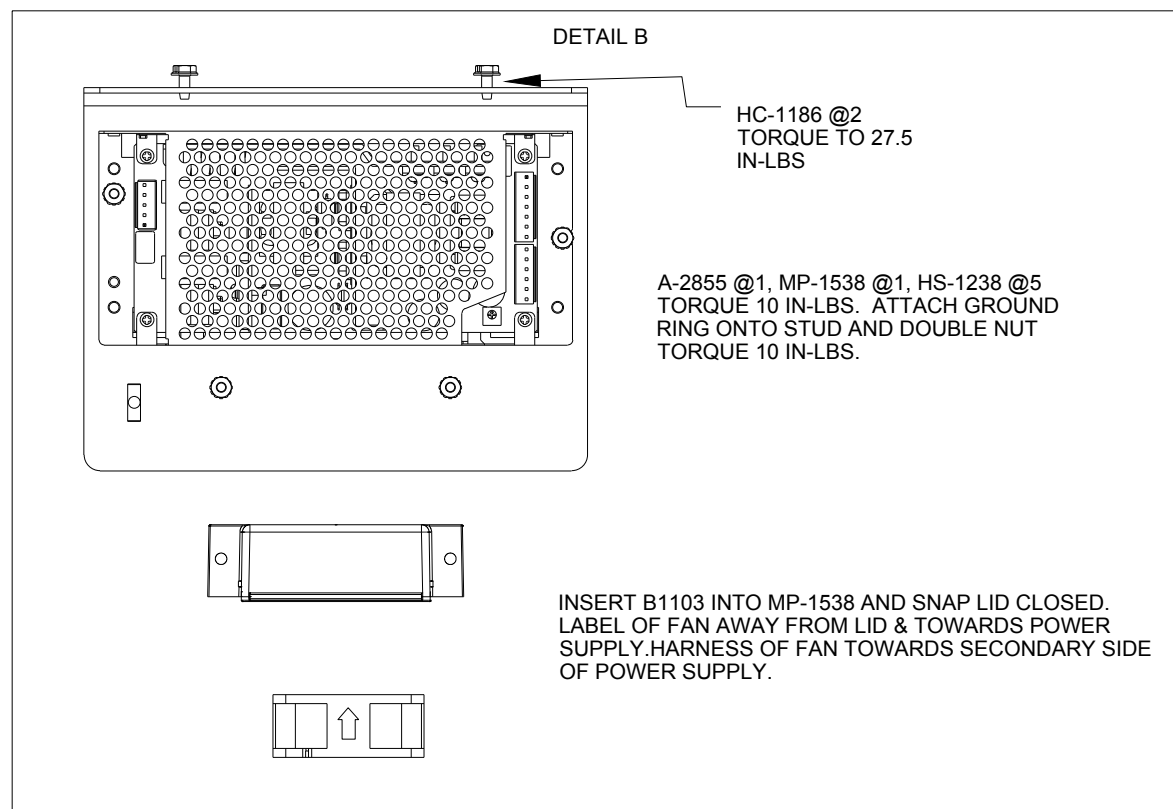

FIBER CONVERTOR AND PLR PLATE. FIELD INSTALLED. (CONFIGURABLE)

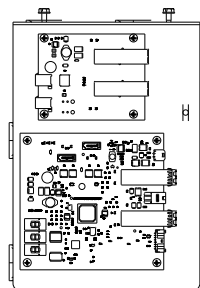

PLR PLATE FIELD INSTALLED. (CONFIGURABLE)

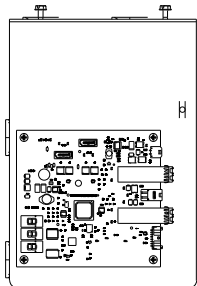

POWER ENTRANCE FIELD INSTALLED (CONFIGURABLE)

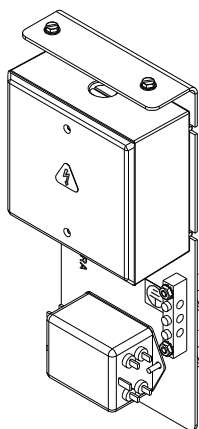

FIELD INSTALLED PARTS (CONFIGURABLE)

		THE CONCEPTS EXPRESSED AND DETAILS SHOWN ON THIS DRAWING ARE CONFIDENTIAL AND PROPRIETARY. DO NOT REPRODUCE BY ANY MEANS WITHOUT THE EXPRESS WRITTEN CONSENT OF DAKTRONICS, INC. OR ITS WHOLLY OWNED SUBSIDIARIES. COPYRIGHT 2018 DAKTRONICS, INC. (USA)			
PROJECT: RTN					
TITLE: COMPONENT PLACEMENT; RTN B1					
DATE: 25 MAY 18	DIM UNITS: INCHES [MILLIMETERS]			SHEET	REV
SCALE: NTS	DO NOT SCALE DRAWING				02
DESIGN: JFIXSEN	JOB NO.	FUNC - TYPE - SIZE			
DRAWN: JFIXSEN	P2094	F - 01 - B	3929851		

REV 02	DATE: 6 AUG 18	UPDATED HC-1238 TO 5 INSTEAD OF 4.	BY: JSF
REV 01	DATE: 16 JUL 18	CN59558 UPDATED THE MOUNTING FOR THE MOUNTING BRACKET. POWER SUPPLY PLATE FAN MOUNTING CLARIFICATION.	BY: JSF

0A-1487-6859			
INDEX	NAME	QTY	DESCRIPTION
1	OP-1273-0062	1	COATED; FIBER OPTIC CONVERTER
2	OP-1525-6054	1	Op-1525-6054.asm
3	OS-3920587	1	PLR PLATE ASM; RTN-301, B1
4	HC-1012	4	MACH SCR, #6-32 X 0.375, PHIL PAN HEAD, ZN PLTD
5	HC-1186	2	TAP SCR, #10-16 X 0.375, PHIL HEX WSHR HEAD
6	HC-1379	4	MACH SCR; #6-32 X 0.250, PHIL FLAT HEAD, ZN PLTD,

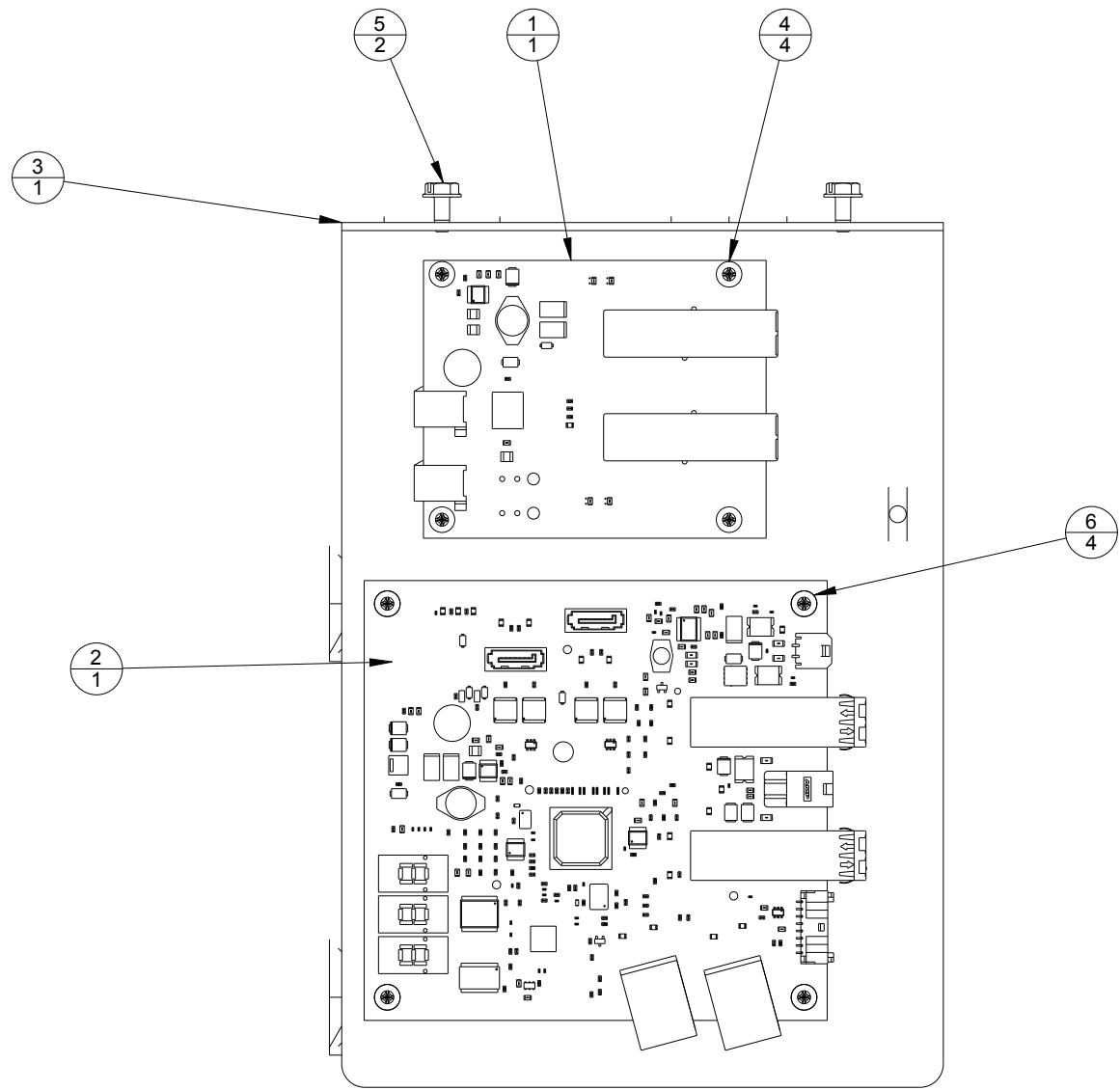

\*\*TORQUE HC-1012 TO 5 IN-LBS

REV 01	DATE: 17 JUL 18	CN59558 CHANGED FROM HC-1012 TO HC-1379 FOR PLR	BY: JSF
		<small>THE CONCEPTS EXPRESSED AND DETAILS SHOWN ON THIS DRAWING ARE CONFIDENTIAL AND PROPRIETARY. DO NOT REPRODUCE BY ANY MEANS WITHOUT THE EXPRESS WRITTEN CONSENT OF DAKTRONICS, INC. OR ITS WHOLLY OWNED SUBSIDIARIES. COPYRIGHT 2018 DAKTRONICS, INC. (USA)</small>	
PROJECT: RTN			
TITLE: ASSY; PLR 6054 & FIBER CONVERTOR, W/ MTG, RTN-B1			
DATE: 17-JUL-18	DIM UNITS: INCHES [MILLIMETERS]	SHEET	REV
SCALE: 1/2	DO NOT SCALE DRAWING	1 OF 1	01
DESIGN: JFIXSEN	JOB NO. P2094	FUNC - TYPE - SIZE	3929854
DRAWN: JFIXSEN		E - 07 - B	

**0A-1487-6025**

INDEX	NAME	QTY	DESCRIPTION
1	0P-1525-6054	1	0p-1525-6054.asm
2	0S-3967917	1	PLR PLATE; RTN-301, B1
3	HC-1186	2	TAP SCR, #10-16 X 0.375, PHIL HEX WSHR HEAD
4	HC-1379	4	MACH SCR; #6-32 X 0.250, PHIL FLAT HEAD, ZN PLTD,

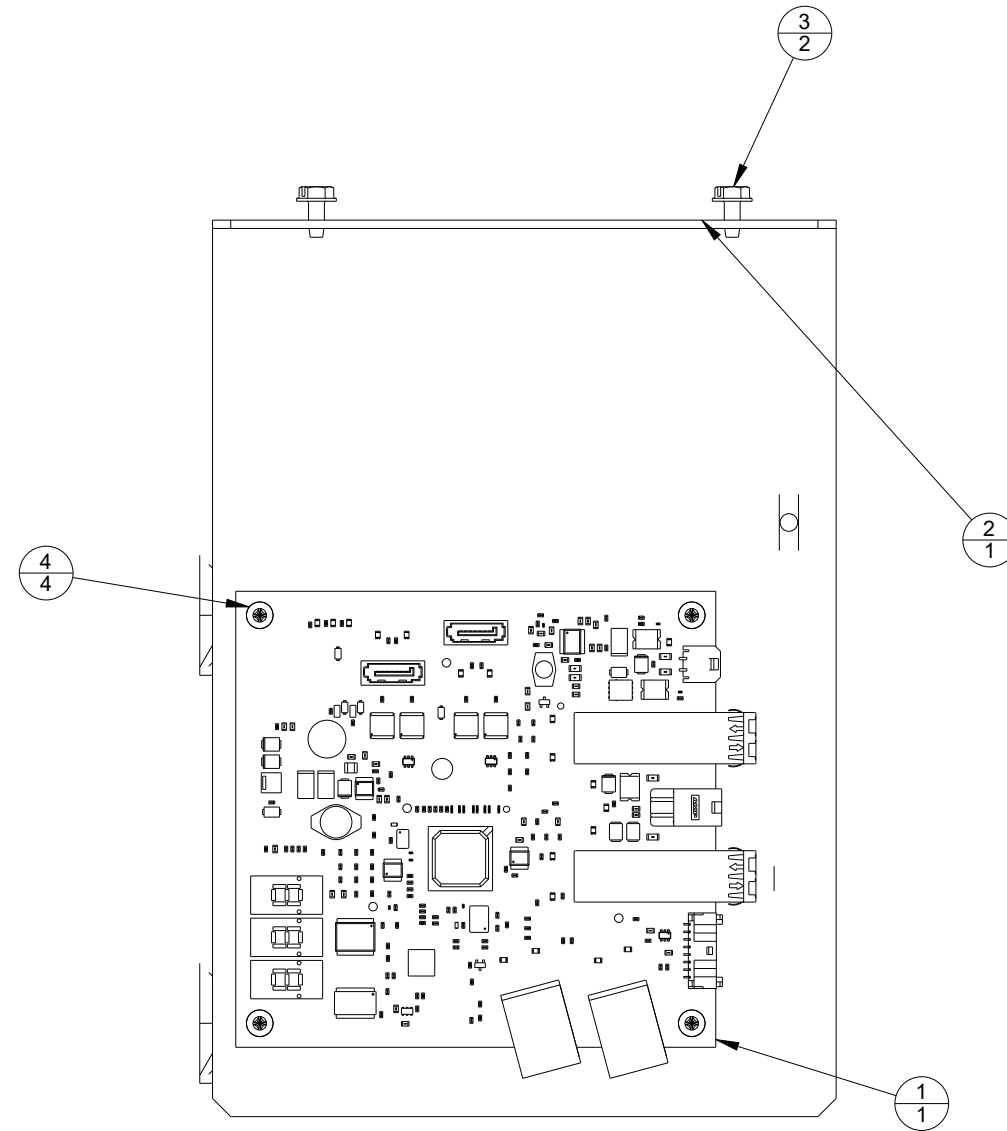

TORQUE HC-1379 TO 5 IN-LBS

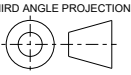
REV 01	DATE: 16 JUL 18	CN59558 CHANGED MOUNTING PLATE TO REMOVE NUTSERTS FOR THE FIBER CONVERTOR	BY: JSF
		THE CONCEPTS EXPRESSED AND DETAILS SHOWN ON THIS DRAWING ARE CONFIDENTIAL AND PROPRIETARY. DO NOT REPRODUCE BY ANY MEANS WITHOUT THE EXPRESS WRITTEN CONSENT OF DAKTRONICS, INC. OR ITS WHOLLY OWNED SUBSIDIARIES. COPYRIGHT 2018 DAKTRONICS, INC. (USA)	THIRD ANGLE PROJECTION 
PROJECT: RTN			
TITLE: ASSY; PLR 6054 W/ MTG, RTN-B1			
DATE: 09-JUL-18	DIM UNITS: INCHES [MILLIMETERS]	SHEET	REV
SCALE: 1/2	DO NOT SCALE DRAWING	1 OF 1	01
DESIGN: JFIXSEN	JOB NO. P2094	FUNC - TYPE - SIZE	3929866
DRAWN: JFIXSEN		E - 07 - B	

**SATA ROUTING RULES**

FOR RTN-301 SIGNAL ROUTING WILL BE DONE USING SATA CABLES. SATA CABLES WILL BE IN THE PANELS FROM THE FACTORY AND WILL JUST NEED TO BE INTERCONNECTED ONSITE.

**FIELD CONFIGURABLE PLR**

THE PLR ASSEMBLY WILL BE A FIELD CONFIGURABLE UNIT AGAIN. ASSEMBLY 0A-1487-6025. PLR PLUGS INTO POWER SUPPLY FAN HARNESS.  
 \*\*\*\*IF USING HLG POWER SUPPLIES 0A-2094-7001 WILL ALSO BE REQUIRED FOR EVERY PLR.

**FIELD CONFIGURABLE FIBER CONVERTER**

THE FIBER CONVERTER ASSEMBLY WILL BE A FIELD CONFIGURABLE UNIT AGAIN. ASSEMBLY 0A-1487-6859. PLR PLUGS INTO POWER SUPPLY FAN HARNESS  
 \*\*\*\*IF USING HLG POWER SUPPLIES 0A-2094-7001 WILL ALSO BE REQUIRED FOR EVERY PLR.

IN FROM PLR SATA PORT OR PREVIOUS SECTION CABLE

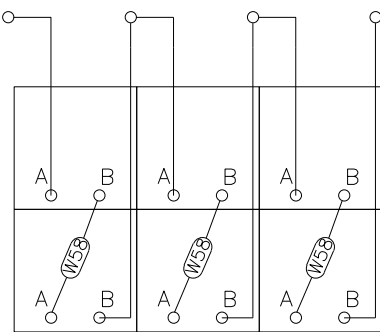

TO TOP MOD IN NEXT SECTION OR PLR (BASED ON INTERCONNECT DWG)

WING SECTION IS SHOWN NO BRACKET MOUNTED ON WING.

MOUNTING BRACKETS MOUNTED TO MAIN STRAIGHT SECTION REFER TO DETAIL A

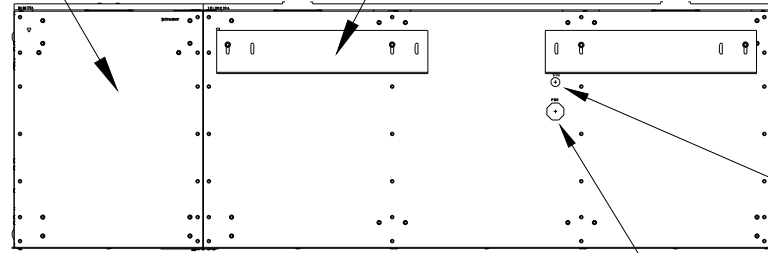

REAR VIEW

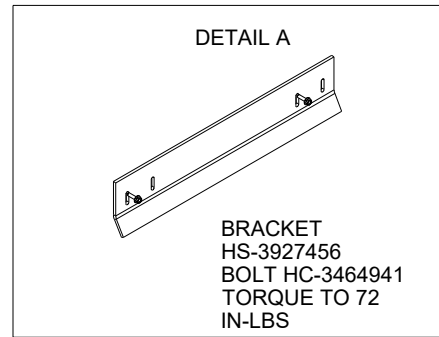

0A-2293-7XXX INSTALLED IN PANEL.

DETAIL A

BRACKET HS-3927456  
 BOLT HC-3464941  
 TORQUE TO 72 IN-LBS

PLR LOCATION 1ST COLUMN FROM THE LEFT (FROM FRONT) (CONFIGURABLE)

POWER LEFT J-BOX INSTALL LOCATION ALSO REQUIRES HARNESS

POWER J-BOX LOCATION 2ND COLUMN FROM THE LEFT (FROM FRONT) (CONFIGURABLE)

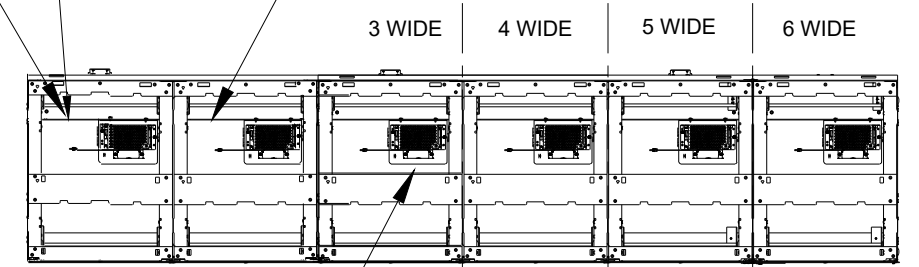

FRONT VIEW

ONSITE SIGNAL CONDUIT INSTALL LOCATION

ONSITE POWER CONDUIT INSTALL LOCATION

POWER SUPPLY WITH FAN ON PLATE. ONE POWER SUPPLY PLATE PER COLUMN REFER TO DETAIL B.

**HORIZONTAL POWER ROUTING**

WHEN ROUTING INTERNAL AC POWER CONNECTIONS THE BUSS HARNESS WILL CONNECT TO THE BUSS HARNESS OF THE PREVIOUS/NEXT CABINET UNLESS THERE IS A POWER ENTRANCE. REFER TO RISER DIAGRAM FOR POWER ENTRANCE LOCATIONS.

POWER ENTRANCE INSTALLED ONSITE

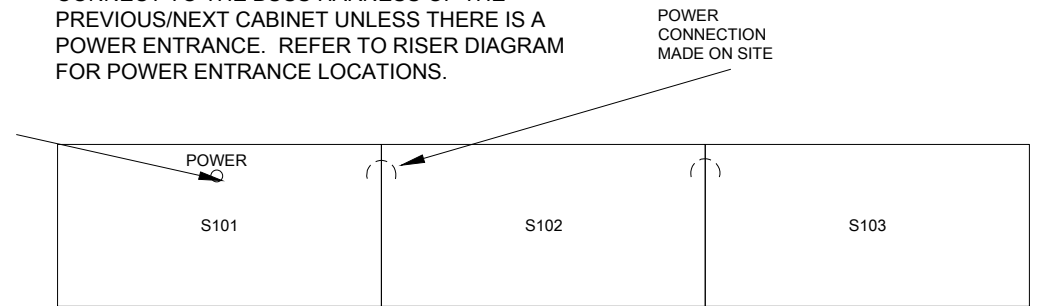

FIBER CONVERTOR AND PLR PLATE. FIELD INSTALLED. (CONFIGURABLE)

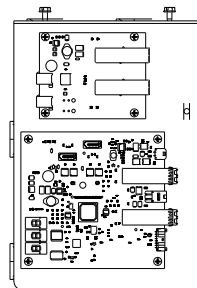

PLR PLATE FIELD INSTALLED. (CONFIGURABLE)

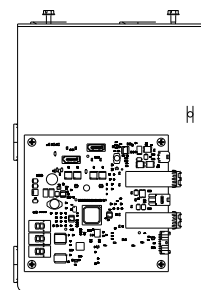

POWER ENTRANCE FIELD INSTALLED (CONFIGURABLE)

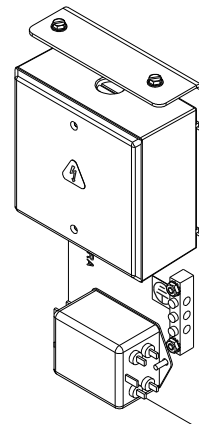

FIELD INSTALLED PARTS (CONFIGURABLE)

			THE CONCEPTS EXPRESSED AND DETAILS SHOWN ON THIS DRAWING ARE CONFIDENTIAL AND PROPRIETARY. DO NOT REPRODUCE BY ANY MEANS WITHOUT THE EXPRESS WRITTEN CONSENT OF DAKTRONICS, INC. OR ITS WHOLLY OWNED SUBSIDIARIES. COPYRIGHT 2022 DAKTRONICS, INC. (USA)		
PROJECT: RTN-B1					
TITLE: RTN-301 FIELD WIRING GUIDE					
DATE: 14 NOV 22	DIM UNITS: INCHES [MILLIMETERS]		SHEET	REV 00	
SCALE: NTS			DO NOT SCALE DRAWING		
DESIGN: JFIXSEN	JOB NO. P2094	FUNC - TYPE - SIZE R - 06 - B		5169344	
DRAWN: JFIXSEN					

## **C Daktronics Warranty & Limitation of Liability**

This section includes the Daktronics Warranty & Limitation of Liability statement.

*This page intentionally left blank.*

# DAKTRONICS WARRANTY & LIMITATION OF LIABILITY

This Warranty and Limitation of Liability (the “Warranty”) sets forth the warranty provided by Daktronics with respect to the Equipment. By accepting delivery of the Equipment, Purchaser and End User agree to be bound by and accept these terms and conditions. Unless otherwise defined herein, all terms within the Warranty shall have the same meaning and definition as provided elsewhere in the Agreement.

DAKTRONICS WILL ONLY BE OBLIGATED TO HONOR THE WARRANTY SET FORTH IN THESE TERMS AND CONDITIONS UPON RECEIPT OF FULL PAYMENT FOR THE EQUIPMENT

## 1. Warranty Coverage.

- A. Daktronics warrants to the original end user (the “End User”, which may also be the Purchaser) that the Equipment will be free from Defects (as defined below) in materials and workmanship for a period of one (1) year (the “Warranty Period”). The Warranty Period shall commence on the earlier of: (i) four weeks from the date that the Equipment leaves Daktronics’ facility; or (ii) Substantial Completion as defined herein. The Warranty Period shall expire on the first anniversary of the commencement date.  
  
“Substantial Completion” means the operational availability of the Equipment to the End User in accordance with the Equipment’s specifications, without regard to punch-list items, or other non-substantial items which do not affect the operation of the Equipment
- B. Daktronics’ obligation under this Warranty is limited to, at Daktronics’ option, replacing or repairing, any Equipment or part thereof that is found by Daktronics not to conform to the Equipment’s specifications. Unless otherwise directed by Daktronics, any defective part or component shall be returned to Daktronics for repair or replacement. This Warranty does not include on-site labor charges to remove or install these components. Daktronics may, at its option, provide on-site warranty service. Daktronics shall have a reasonable period of time to make such replacements or repairs and all labor associated therewith shall be performed during regular working hours. Regular working hours are Monday through Friday between 8:00 a.m. and 5:00 p.m. at the location where labor is performed, excluding any holidays observed by Daktronics.
- C. Daktronics shall pay ground transportation charges for the return of any defective component of the Equipment. All such items shall be shipped by End User DDP Daktronics designated facility per Incoterms® 2020. If returned Equipment is repaired or replaced under the terms of this Warranty, Daktronics will prepay ground transportation charges back to End User and shall ship such items DDP End User’s designated facility per Incoterms® 2020; otherwise, End User shall pay transportation charges to return the Equipment back to the End User and such Equipment shall be shipped Ex Works Daktronics designated facility per Incoterms® 2020. All returns must be pre-approved by Daktronics before shipment. Daktronics shall not be obligated to pay freight for any unapproved return. End User shall pay any upgraded or expedited transportation charges
- D. Any replacement parts or Equipment will be new or serviceably used, comparable in function and performance to the original part or Equipment and warranted for the remainder of the Warranty Period. Purchasing additional parts or Equipment from the Seller does not extend the Warranty Period.
- E. Defects shall be defined as follows. With regard to the Equipment (excepting LEDs), a “Defect” shall refer to a material variance from the design specifications that prohibit the Equipment from operating for its intended use. With respect to LEDs, “Defects” are defined as LED pixels that cease to emit light. Unless otherwise expressly provided, this Warranty does not impose any duty or liability upon Daktronics for partial LED pixel degradation. Notwithstanding the foregoing, in no event does this Warranty include LED pixel degradation caused by UV light. This Warranty does not provide for the replacement or installation of communication methods including but not limited to, wire, fiber optic cable, conduit, trenching, or for the purpose of overcoming local site interference radio equipment substitutions.

EXCEPT AS OTHERWISE EXPRESSLY SET FORTH IN THIS WARRANTY, TO THE MAXIMUM EXTENT PERMITTED BY APPLICABLE LAW, DAKTRONICS DISCLAIMS ANY AND ALL OTHER PROMISES, REPRESENTATIONS AND WARRANTIES APPLICABLE TO THE EQUIPMENT AND REPLACES ALL OTHER WARRANTIES OR CONDITIONS, EXPRESS OR IMPLIED, INCLUDING, BUT NOT LIMITED TO, ANY IMPLIED WARRANTIES OR CONDITIONS OF MERCHANTABILITY, FITNESS FOR A PARTICULAR PURPOSE, OR ACCURACY OR QUALITY OF DATA. OTHER ORAL OR WRITTEN INFORMATION OR ADVICE GIVEN BY DAKTRONICS, ITS AGENTS OR EMPLOYEES, SHALL NOT CREATE A WARRANTY OR IN ANY WAY INCREASE THE SCOPE OF THIS LIMITED WARRANTY.

THIS LIMITED WARRANTY IS NOT TRANSFERABLE.

## 2. Exclusion from Warranty Coverage

This Warranty does not impose any duty or liability upon Daktronics for any:

- A. damage occurring at any time, during shipment of Equipment unless otherwise provided for in the Agreement. When returning Equipment to Daktronics for repair or replacement, End User assumes all risk of loss or damage, agrees to use any shipping containers that might be provided by Daktronics, and to ship the Equipment in the manner prescribed by Daktronics;
- B. damage caused by: (i) the improper handling, installation, adjustment, use, repair, or service of the Equipment, or (ii) any physical damage which includes, but is not limited to, missing, broken, or cracked components resulting from non-electrical causes;



# DAKTRONICS WARRANTY & LIMITATION OF LIABILITY

altered, scratched, or fractured electronic traces; missing or gauged solder pads; cuts or clipped wires; crushed, cracked, punctured, or bent circuit boards; or tampering with any electronic connections, provided that such damage is not caused by personnel of Daktronics or its authorized repair agents;

- C. damage caused by the failure to provide a continuously suitable environment, including, but not limited to: (i) neglect or misuse; (ii) improper power including, without limitation, a failure or sudden surge of electrical power; (iii) improper air conditioning, humidity control, or other environmental conditions outside of the Equipment's technical specifications such as extreme temperatures, corrosives and metallic pollutants; or (iv) any other cause other than ordinary use;
- D. damage caused by fire, flood, earthquake, water, wind, lightning or other natural disaster, strike, inability to obtain materials or utilities, war, terrorism, civil disturbance, or any other cause beyond Daktronics' reasonable control;
- E. failure to adjust, repair or replace any item of Equipment if it would be impractical for Daktronics personnel to do so because of connection of the Equipment by mechanical or electrical means to another device not supplied by Daktronics, or the existence of general environmental conditions at the site that pose a danger to Daktronics personnel;
- F. statements made about the product by any salesperson, dealer, distributor or agent, unless such statements are in a written document signed by an officer of Daktronics. Such statements as are not included in a signed writing do not constitute warranties, shall not be relied upon by End User and are not part of the contract of sale;
- G. damage arising from the use of Daktronics products in any application other than the commercial and industrial applications for which they are intended, unless, upon request, such use is specifically approved in writing by Daktronics;
- H. replenishment of spare parts. In the event the Equipment was purchased with a spare parts package, the parties acknowledge and agree that the spare parts package is designed to exhaust over the life of the Equipment, and as such, the replenishment of the spare parts package is not included in the scope of this Warranty;
- I. security or functionality of the End User's network or systems, or anti-virus software updates;
- J. performance of preventive maintenance;
- K. third-party systems and other ancillary equipment, including without limitation front-end video control systems, audio systems, video processors and players, HVAC equipment, batteries and LCD screens;
- L. incorporation of accessories, attachments, software or other devices not furnished by Daktronics; or
- M. paint or refinishing the Equipment or furnishing material for this purpose.

### 3. Limitation of Liability

- A. Daktronics shall be under no obligation to furnish continued service under this Warranty if alterations are made to the Equipment without the prior written approval of Daktronics.
- B. It is specifically agreed that the price of the Equipment is based upon the following limitation of liability. In no event shall Daktronics (including its subsidiaries, affiliates, officers, directors, employees, or agents) be liable for any claims asserting or based on (a) loss of use of the facility or equipment; lost business, revenues, or profits; loss of goodwill; failure or increased cost of operations; loss, damage or corruption of data; loss resulting from system or service failure, malfunction, incompatibility, or breaches in system security; or (b) any special, consequential, incidental or exemplary damages arising out of or in any way connected with the Equipment or otherwise, including but not limited to damages for lost profits, cost of substitute or replacement equipment, down time, injury to property or any damages or sums paid to third parties, even if Daktronics has been advised of the possibility of such damages. The foregoing limitation of liability shall apply whether any claim is based upon principles of contract, tort or statutory duty, principles of indemnity or contribution, or otherwise
- C. In no event shall Daktronics be liable for loss, damage, or injury of any kind or nature arising out of or in connection with this Warranty in excess of the Purchase Price of the Equipment. The End User's remedy in any dispute under this Warranty shall be ultimately limited to the Purchase Price of the Equipment to the extent the Purchase Price has been paid.

### 4. Assignment of Rights

- A. The Warranty contained herein extends only to the End User (which may be the Purchaser) of the Equipment and no attempt to extend the Warranty to any subsequent user-transferee of the Equipment shall be valid or enforceable without the express written consent of Daktronics.

### 5. Governing Law; Election of Remedies

- A. The rights and obligations of the parties under this Warranty shall not be governed by the provisions of the United Nations Convention on Contracts for the International Sales of Goods of 1980. The parties consent to the application of the laws of the State of South Dakota to govern, interpret, and enforce each of the parties' rights, duties, and obligations arising from, or relating in any manner to, the subject matter of this Warranty, without regard to conflict of law principles.
- B. Any dispute, controversy or claim arising from or related to this Warranty, the parties shall first attempt to settle through negotiations. In the event that no resolution is reached, then such dispute, controversy, or claim shall be resolved by final and binding arbitration under the Rules of Arbitration of the International Chamber of Commerce. The language of the arbitration

# DAKTRONICS WARRANTY & LIMITATION OF LIABILITY

shall be English. The place of the arbitration shall be Sioux Falls, SD. A single arbitrator selected by the parties shall preside over the proceeding. If a single arbitrator cannot be agreed upon by the parties, each party shall select an arbitrator, and those arbitrators shall confer and agree on the appointed arbitrator to adjudicate the arbitration. The arbitrator shall have the power to grant any provisional or final remedy or relief that it deems appropriate, including conservatory measures and an award of attorneys' fees. The arbitrator shall make its decisions in accordance with applicable law. By agreeing to arbitration, the Parties do not intend to deprive any court of its jurisdiction to issue a pre-arbitral injunction, pre-arbitral attachment, or other order in aid of arbitration proceedings and the enforcement of any award. Without prejudice to such provisional remedies as may be available under the jurisdiction of a court, the arbitrator shall have full authority to grant provisional remedies and to direct the Parties to request that any court modify or vacate any temporary or preliminary relief issued by such court, and to award damages for the failure of any Party to respect the arbitrator's orders to that effect.

## 6. Availability of Extended Service Agreement

- A. For End User's protection, in addition to that afforded by the warranties set forth herein, End User may purchase extended warranty services to cover the Equipment. The Extended Service Agreement, available from Daktronics, provides for electronic parts repair and/or on-site labor for an extended period from the date of expiration of this warranty. Alternatively, an Extended Service Agreement may be purchased in conjunction with this Warranty for extended additional services. For further information, contact Daktronics Customer Service at 1-800-DAKTRONics (1-800-325-8766).

### Additional Terms applicable to sales outside of the United States

The following additional terms apply **only** where the installation site of the Equipment is located outside of the United States of America.

1. In the event that the installation site of the Equipment is in a country other than the U.S.A., then, notwithstanding Section 5 of the Warranty, where the selling entity is the entity listed in Column 1, then the governing law of this Warranty is the law of the jurisdiction listed in the corresponding row in Column 2 without regard to its conflict of law principles. Furthermore, if the selling entity is an entity listed in Column 1, then the place of arbitration is listed in the corresponding row in Column 3.

Column 1 (Selling Entity)	Column 2 (Governing Law)	Column 3 (Location of Arbitration)
Daktronics, Inc.	The state of Illinois	Chicago, IL, U.S.A.
Daktronics Canada, Inc.	The Province of Ontario, Canada	Toronto, Ontario, Canada
Daktronics UK Ltd.	England and Wales	Bristol, UK
Daktronics GmbH	The Federal Republic of Germany	Wiesbaden, Germany
Daktronics Hong Kong Limited	Hong Kong, Special Administrative Region of the P.R.C.	Hong Kong SAR
Daktronics Shanghai Co., Ltd.	The Peoples Republic of China	Shanghai, P.R.C.
Daktronics France, SARL	France	Paris, France
Daktronics Japan, Inc.	Japan	Tokyo, Japan
Daktronics International Limited	Macau, Special Administrative Region of the P.R.C.	Macau SAR
Daktronics Australia Pad Ltd	Australia	Sydney, Australia
Daktronics Singapore Pte. Ltd	Singapore	Singapore
Daktronics Brazil LTDA	Brazil	São Paulo, Brazil
Daktronics Spain S.L.U.	Spain	Madrid, Spain
Daktronics Belgium N. V	Belgium	Kruikebeke, Belgium
Daktronics Ireland Co. Ltd.	Ireland	Dublin, Ireland